



THREE AVIATION MAGAZINES IN ONE!

FLYING ACES

JANUARY
15¢



C.B. MAYSHAN

ATTACK FROM THE STRATOSPHERE

GRIPPING MODERN AND WAR-TIME AIR STORIES
ARTICLES BY WHITEHOUSE, LEWIS AND HUGHES
MODEL PLANS OF LATEST U.S. NAVY PLANES AND OTHERS



Here's a Xmas Gift from HEATHE... Order Today and Get Yours! A Gift With Every Purchase

Here's Heathe's Profit Sharing Plan!

Take your pick, boys... HEATHE wants this to be a real Xmas for you... No matter what you buy, you get a gift... On \$1 purchases you get a very fine patented pencil that repels and propels... On \$3 purchases you get a high quality Sheffield steel, two-blade knife... With \$5 purchases you receive a camera and two rolls of films... With \$8 purchases, a pair of high quality roller skates... On a \$10 purchase, you get a super-quality fountain pen and pencil set in a gift box... Make this a Merry Christmas for yourself and Heathe. Order today—NOW—and get one of the handsome gifts described above.

Model Clubs!
Write for our confidential wholesale prices. They are unbeatable!

A Message to Parents

Here's a tip! Give your boy Heathe models and supplies for Xmas.

Heathe's Guaranteed Supplies

18" Balsa Strips		RUBBER	
1/32x1/16.....	35 for .05	1/32 sq. 25 ft. for.....	.05
1/16x1/16.....	35 for .05	3/32 sq. 15 ft. for.....	.05
1/16x1/8.....	20 for .05	3/32 flat, 15 ft. for.....	.05
1/16x3/16.....	15 for .05	1/8 flat, 15 ft. for.....	.05
1/16x1/4.....	12 for .05	3/16 flat, 10 ft. for.....	.05
3/32x3/32.....	18 for .05	INSIGNIA SHEET	
1/8 x1/8.....	16 for .05	12 pr. and rudder and tail markings with gummed back each.....	
1/8 x3/16.....	12 for .05	INSIGNIAS	
1/8 x1/4.....	8 for .05	(American, French, British or German)	
1/8 x3/8.....	6 for .05	3/4 or 1" 5 pair.....	
3/16x3/16.....	8 for .05	1 1/2 or 2" 3 pair.....	
3/16x1/4.....	5 for .05	3" 1 pair.....	
3/16x3/8.....	4 for .05	WIRE, STRAIGHT LENGTHS	
1/4 x1/4.....	5 for .05	Nos. 5, 6, 7, 8, 9, 10, 11, 12, 14, 15, or 16.....	
1/4 x3/8.....	3 for .05	6 ft. for.....	
1/4 x1/2.....	3 for .05	THRUST BEARINGS	
5/8 x3/8.....	3 for .05	Small or large, 2c each, or 18c per doz.	
1/2 x1/2.....	2 for .05	MODEL PINS	
1/2 x1.....	1 for .05	Per pkg.....	
18" SHEET Balsa		SAND PAPER	
1/8x2.....	4 for .10	Per pkg.....	
1/16x2.....	6 for .10	WASHERS	
3/32x2.....	5 for .10	(1/2 or 3/4 dia.)	
1/8 x2.....	4 for .10	1 doz.....	
3/16x2.....	3 for .10	1 gross.....	
1/4 x2.....	3 for .12	SHEET CELLULOID	
1/2 x2.....	2 for .15	(Transparent)	
(For 3"x18" double 2" width cost)		4"x6.....	
18" Balsa Planks		6"x8.....	
1" x1".....	1 for .07	3" DIA. CELLULOID MOTOR AND DRAG RING COMBINED	
1" x1 1/2".....	1 for .09	(First time on market)	
1" x2".....	1 for .11	Special price.....	
1" x3".....	1 for .15	CELLULOID PANTS	
1" x4".....	1 for .25	For 3/4" or 1" wheel.....	
1 1/2"x1 1/2".....	1 for .15	For 1 1/2" or 1 3/4" wheel.....	
2" x2".....	1 for .20	DUMMY RADIAL ENGINES	
2" x3".....	1 for .25	(Celluloid, 6 cylinders)	
2" x4".....	1 for .35	1 1/2" dia.....	
2" x6".....	1 for .45	2" dia.....	
3" x6".....	1 for .75	3" dia.....	
STANDARD PITCH Balsa Propeller Blocks		CELLULOID WHEELS	
1" x 5.....	9 for .05	3/4" dia. pr.....	
1 1/2" x 5.....	7 for .05	1" dia. pr.....	
1 1/2" x 6.....	7 for .05	1 1/2" dia. pr.....	
1 1/2" x 7.....	3 for .05	1 3/4" dia. pr.....	
1 1/2" x 8.....	2 for .05	Balsa Balloon Wheels	
1 1/2" x 9.....	2 for .06	(Machine turned)	
1 1/2" x 10.....	1 for .04	1/2" dia. per pr.....	
1 1/2" x 12.....	1 for .05	1" dia. per pr.....	
1 1/2" x 15.....	1 for .07	1 1/2" dia. per pr.....	
1" x 1 1/2" x 15.....	1 for .08	3" dia. per pr.....	
BAMBOO		SHEET ALUMINUM	
1/16 sq. x 14.....	25 for .05	.002 thick, per sq. ft.....	
1/16x1/4x11.....	1 for .01	.005 thick, per sq. ft.....	
1/16x1/4x11 1/2 doz.	for .07	.010 thick, per sq. ft.....	
REED		ALUMINUM LEAF	
1/32 or 1/16.....	3 ft. for .02	.0003 of an inch thick, 3 1/2" wide, 5 ft. for.....	
3/32 or 1/8.....	5 ft. for .02	ALUMINUM TUBING	
DOWELS		(Special 1/100" wall)	
1/16" dia. x 12" Per doz.....	.10	1/16 O.D., per ft.....	
1/8" dia. x 18" Per doz.....	.10	3/32 O.D., per ft.....	
3/16" dia. x 18" Per doz.....	.15	1/8 O.D., per ft.....	
COLORLESS CEMENT		3/16 O.D., per ft.....	
1 oz.....	.07	1/4 O.D., per ft.....	
2 oz.....	.16	ALUMINUM COWLINGS	
4 oz.....	.22	8 1/2 Anti-Drage Closed Open	
1 pt.....	.60	1 1/2" 20c 20c 20c	
1 qt.....	1.00	2" 25c 25c 25c	
CLEAR DOPE OR BANANA OIL		2 1/2" 30c 30c 30c	
1 oz.....	.06	3" 35c 35c 35c	
2 oz.....	.11	3 1/2" 40c 40c 40c	
4 oz.....	.20	4" 50c 50c 50c	
1 qt.....	.95	15" FLYING SCALE	
Thinner same price as clear dope		Model Plans	
COLOR DOPE		Curtiss Robin.....	
White, yellow, orange, blue, red, green, olive drab, black, silver, gold.....		Fokker D-VII.....	
1 oz.....	.07	20" PLANS	
2 oz.....	.13	Flying Scale Model	
4 oz.....	.22	Full-size plans, complete with large instruction sheet	
1 pt.....	.65	3 full-size views and all lbs and formers:	
1 qt.....	1.10	Northrop Gamma	
HEATHE GLOSS		Monocoupe	
(To shine up your colored models)		Boeing P-12F	
2 oz.....	.14	Boeing P-26	
4 oz.....	.25	Akron Fighter	
WOOD VENEER		Spad	
(For scale model work)		Vought Corsair	
20"x30" per sheet.....	.20	Curtiss Swift	
20"x15" per sheet.....	.12	15c each—3 for 40c	
JAPANESE TISSUE		DUMMY MACHINE GUNS	
White, per doz.....		Pursuit type gun.....	
Colored, asst. per doz.....		Swivel type gun.....	
All Colors		.10	
GENUINE SUPERFINE TISSUE		.15	
(Cover your champion endurance ships with this.)			
18"x24" per sheet.....	.08		
18"x24" per doz.....	.85		

We Have Again Expanded and Guarantee You 24 Hours Delivery Service!

Sale On New Solid Replica Models 3 for 25¢



If these solid replica models were priced at 25c each, you would say they are good value. With this special offer you can make your selection of the kits of your choice for only 25c for 3. Furnished with full-size plan, separate instruction sheet and all accessories necessary to complete model you select. Your choice of Boeing P-12F, Texaco Sky Chief, Spad, Fokker D-VII, Lockheed Vega or S.E.5.

DON'T ADD POSTAGE ON KITS—WE PAY IT!

Big New Catalog and Boeing P-12F PLAN FREE With every order, we include free our new big catalog and Boeing P-12F plan.

YOU GET A FREE GIFT WITH EVERY PURCHASE!

Sensational Record Breaking Flying Models

93c EACH

Hawk's Sky Chief

20 Inch 93c EACH

Flying Scale Model Kits

93c

Flights of 1,000 to 2,000 ft. have been made with these 20" flying scale IKATIE models. Carved Props included with finished Wire Parts and 5 Bottles of Cement, dope and colored dope, semi-finished pants and cowls (Choice of Texaco, Sky-Chief, Monocoupe, Boeing P-12F, Akron Fighter, Boeing P-26, Curtiss Swift, Vought Corsair, Spad.

We Pay Postage

Boeing P-12F

Akron Fighter

Every HEATHE kit contains large simplified plans, all accessories—everything to complete your model.

15 Inch Flying Model Kits

Curtiss Robin

2 for 59¢

Amazing value! Contains same supplies as 20" kits. Both: Fokker D-VII and Curtiss Robin.

MORE THAN WE PROMISED!—Mother and Dad thought I should write you. I received my 20" Boeing P-12F and my Hawk Sky Chief kits. You certainly give outstanding value and more than you promised in your advertising!—Lawrence Ross, 677 12th St., Milwaukee, Wis.

MORE THAN SATISFIED!—I saw your ad so many times but always hesitated to order by mail. Frankly, I was afraid of getting "kyped." Now that I did place an order with you and received my model supplies, I feel very small for ever questioning your reliability. It was very nice of you to give me extra measure and I will tell all my friends about Heathe. You can look to me for more orders very soon!—Bob Meyer, 2 Otisfield St., Brockton, Mass.

ACCESSORIES THAT DEFEY COMPETITION

Be sure to include an order for accessories at these low HEATHE prices... each item precision made and exacting in all details.	BOMBS	PURSUIT MACHINE GUNS	DOUBLE ACTION PURSUIT GUNS	CARVED PROPS WITH HOLES DRILLED
	1 1/2" long..... 4c ea.	3/4" Pursuit Gun 5c ea.	1 1/2" long..... 25c ea.	5"..... 8c ea.
	3" long..... 9c ea.	1" Pursuit Gun 5c ea.	2" long..... 15c ea.	7"..... 12c ea.
	1 1/2" long..... 14c ea.	1 1/2" Pursuit Gun 10c ea.	3" long..... 20c ea.	MOTOR NOSE PLATES
	2" long..... 19c ea.	3" Swivel Guns 10c ea.	4" long..... 25c ea.	For 1 1/2" motor 10c ea.
	3" long..... 24c ea.	1 1/2" long..... 10c ea.	5" long..... 30c ea.	For 2" motor 15c ea.
	1 1/2" long..... 10c ea.	3" long..... 15c ea.		For 3" motor 20c ea.
	3" long..... 15c ea.			

HOW TO ORDER

No orders under 50c. Add 15c for packing and postage to orders under \$1.50. Orders over \$1.50 add 10% of order. When ordering 36" lengths add extra 10c. Canada 10c extra. Add 10c to cover postage for rubber. Your gift is sent with your order.

NOTICE TO DEALERS!

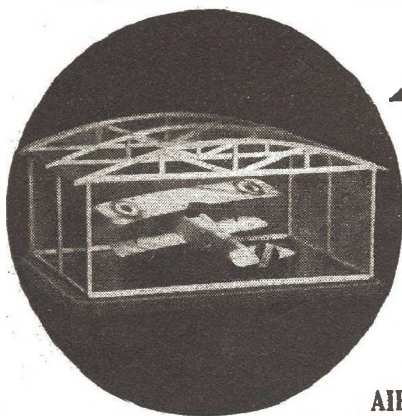
The Heathe Line sells fast because Heathe kits are in the right price range—3 for 25c—35c and \$1.00! More than that our line is so complete that model builders can build a FLEET thus bringing profitable repeat business to you. Tie up to a line that offers you quality at a profit plus 24-hour service. Ask about our special "66" kit Deal! Ask for our Giant Displays.

HEATHE MODEL AIRPLANE CO.

438-201 East 98th Street
Brooklyn, N. Y.

Our prices go up next month: LAST CALL!

LAWRENCE CHRISTMAS SPECIALS



AIRPLANE WITH HANGAR

CONSTRUCTION SETS DELUXE
PATENT PENDING

POSITIVELY THE ONLY COMBINATION
AIRPLANE WITH HANGAR KITS ON THE MARKET



Actual Photo of Finished $\frac{1}{4}$ " Scale Model and Hangar Built from Lawrence Kit.

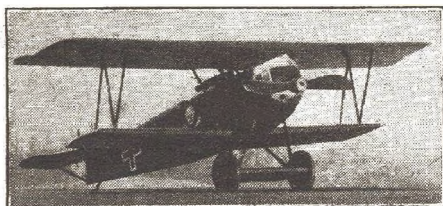
THESE KITS ARE THE LAST WORD!

Actual Photo of Airplane with Hangar Kit Box and Contents.

Each finished model can now have its own transparent, dust proof, celluloid hangar to keep it clean and safe. The large multi-colored gift box ($1\frac{1}{4} \times 5\frac{1}{2} \times 11\frac{1}{2}$ "), and the attractive arrangement of its contents will make your fingers itch to start work. All eight pursuit planes shown in the photographs below can be had in the new combination kits with hangar. These wonderful new kits specially priced at only

\$1.00 EACH
POST-PAID

LAWRENCE ADVANCED SOLID SCALE KITS



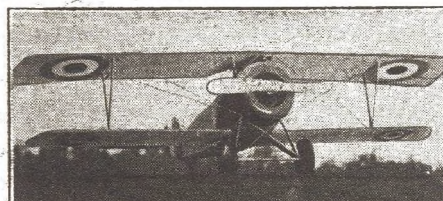
FOKKER D-VII



SOPWITH CAMEL



PFALZ D-XII

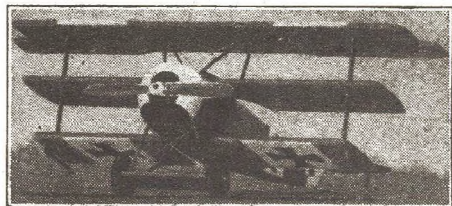


NIEUPORT XVII

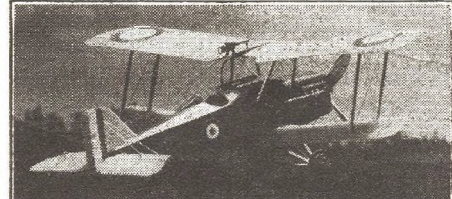
Just Imagine!

THESE ADVANCED KITS CONTAIN—

FINISHED DIE CAST MACHINE GUNS, (Very seldom furnished);
SOLID MAHOGANY MACHINE CARVED PROPELLER, (Not a marked block of wood or bent piece of metal);
FINISHED HARDWOOD WHEELS Turned to Exact Shape and Size, (Not circles printed on flat wood);
SEPARATE, FINISHED ROTARY MOTOR COWLINGS, Accurately Shaped, (Not a part of fuselage block);
SEMI-FINISHED, ACCURATELY CUT FUSELAGE Block, (Not just a rough piece of wood);
INDIVIDUAL AND COMPLETE SET OF INSIGNIA in Correct Colors, Size and Design for Each Model, (Not the same size set for all models);
ACCURATE, SMOOTH WINGS, Cut to Correct Thickness and Semi-Finished, (Not printed on rough, flat wood);
FINE GRAINED PINE STRUTS, Cut to Correct Size, (No bamboo to split and trim);
SEMI-STREAMLINED AXLE-WINGS, When Needed, (Not just a strip of wood);
SPECIAL NICKEL-PLATED PINS for Mounting Wheels and Propeller, (Not usually supplied);
SMOOTH, ROUND HARDWOOD of Correct Size for Exhaust Pipes, Etc., (Not usually included);
QUICK SANDING WOOD FILLER to give Smooth, Non-Porous Surface, (Very seldom furnished);
THREE OR MORE COLORS OF GLOSS LACQUER, (Not one-dram vials or water color cakes);
OUR OWN QUICK POLISHING COMPOUND, Producing a Mirror Finish, (Positively a new item to be found ONLY in LAWRENCE ADVANCED KITS);
A SEPARATE BRUSH FOR EVERY COLOR, (Who ever heard of that in a kit before?);
ASSORTED GRADES OF SANDPAPER, (Just another unusual feature);
And Most Important of All, an AUTHENTIC LAWRENCE PLAN accurately drawn to standard $\frac{1}{4}$ -inch-to-the-foot scale, including detailed MACHINE GUNS, motor, rigging, etc. Full and Complete Instructions covering Every Detail of Construction and Finishing are included with each kit.



FOKKER TRIPLANE



S.E.5A



ALBATROSS D-III



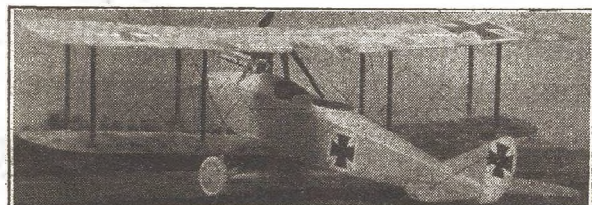
S.P.A.D. XIII

FOKKER D-VII	S.E. 5A	SOPWITH SNIPE
SOPWITH CAMEL	PFALZ D-III	ALBATROSS D-III
S. P. A. D. XIII	NIEUPORT XVII	ROLAND D-II
FOKKER TRIPLANE	SOPWITH TRIPLANE	

ORDER NOW! Advanced Pursuit Kits, Only **50¢** Each

Add 10c per kit to cover postage, packing and insurance.

TWO NEW LAWRENCE ADVANCED TWO SEATER KITS

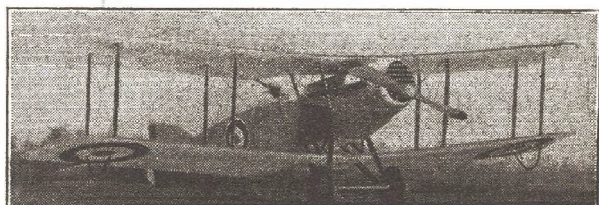


TWO SEATER RUMPLER C-V

Larger Than Pursuit Kits, with Extra Color, Lacquer and Guns.

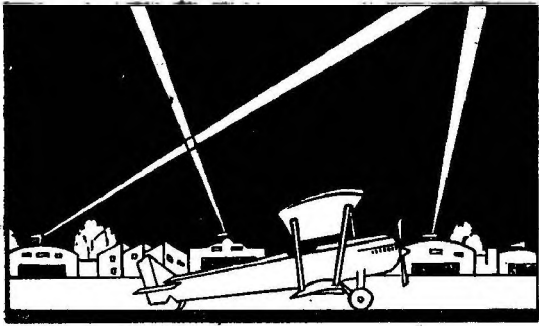
TWO SEATER KITS ONLY **75¢** Each

Add 10c Per Kit for Postage and Insurance



TWO SEATER BRISTOL FIGHTER

LAWRENCE AIRPLANE MODELS, 612 Randolph-Franklin Bldg., Chicago, Illinois
WE POSITIVELY GUARANTEE SHIPMENT WITHIN 48 HOURS



Three Magazines in One!
Fiction, Fact, Model Building

The New, Bigger, Better

FLYING ACES

A.A. WYN, Editor

VOLUME XIX

JANUARY, 1935

NUMBER 2

EVERY STORY COMPLETE—NO SERIALS

CLAWS OF THE HAWK	DONALD E. KEYHOE	4
A threatening shadow loomed in the Pacific. Modern air novel.		
LIGHTHOUSE KEEPERS OF THE SKY	LIEUT. H. LATANE LEWIS II	8
The radio beam spells safety to every airman.		
ATTACK FROM THE STRATOSPHERE	C. B. MAYSHARK	10
An air battle of the future — on this month's cover.		
AN ITCH IN TIME	JOE ARCHIBALD	11
Phineas' future was bright — like a vat of tar!		
AT SUICIDE PASS	EDWARDS A. DORCET	16
From that graveyard of pilots there was no return.		
THE SQUADRON THAT WOULD NOT SURRENDER	JAMES P. HUGHES	19
Out of that order to surrender came one of the war's strangest dramas.		
THE DECOY DUEL	ROBERT H. LEITFRED	22
Only one man knew death lay behind that weird rendezvous.		

MODEL MAKERS' SECTION

WITH THE MODEL BUILDERS		31
BUILD THE BERLINER-JOYCE OJ-2	AVRUM ZIER	32
THE BOEING XF6B-1 NAVY FIGHTER	STOCKTON FERRIS, JR.	39
THE FLYING ACES OUTDOOR CONTEST GLIDER	JULIUS UNRATH	40
FROM THE MODEL BUILDER'S WORKBENCH		40

DEPARTMENTS AND FEATURES

SNAPSHOTS OF THE WAR	7	PICTORIAL FLYING COURSE	29
FIGHTERS OF FOUR NATIONS	15	WISECRACK-UPS	30
THE FLYING ARSENAL	18	CITATIONS AND AWARDS	43
LIVES OF THE ACES	21	JOIN THE FLYING ACES CLUB	43
HAPPY LANDINGS	25	FLYING ACES CLUB NEWS	44
WAR PLANES ALBUM	26	MISSING WORDS CONTEST NO. 9	45
HERE AND THERE IN THE AIR	28	IN THE NEXT ISSUE	47
PILOTOPICS	28	ADVERTISER'S CONTACT	63

Cover Painting by C. B. Mayshark

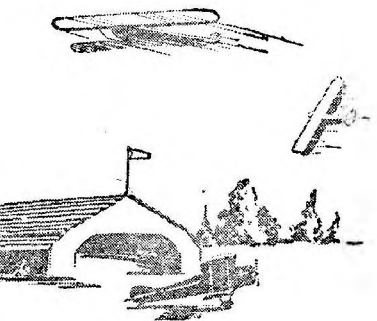
Published monthly by Magazine Publishers, Inc.; office of publication, 29 Worthington St., Springfield, Mass. A. A. Wyn, President; Warren A. Angel, Secretary-Treasurer. Editorial and executive offices, 67 W. 44th St., New York. Entered as second-class matter, Nov. 14, 1928, at Springfield, Mass., under Act of March 3, 1879. Title registered in U. S. Patent Office. Copyright, 1933, by Magazine Publishers, Inc. Nothing may be reprinted without permission of the publishers. Manuscripts will be handled with care, but this magazine assumes no responsibility for their safety. For advertising rates address FLYING ACES Magazine, 67 W. 44th St., New York City.

Twelve Issues, \$1.50

Single Copies, Fifteen Cents

Prepare Quickly at Home in Spare Time

FOR A
Good Pay Job
 IN THE
Fast-Growing
AVIATION
INDUSTRY



WALTER HINTON: trail blazer, pioneer, explorer, author, instructor, AVIATOR. The first man to pilot a plane across the Atlantic, the famous NC-4, and the first to fly from North to South America. The man who was a crack flying instructor for the Navy during the War; who today is training far-sighted men for Aviation. Hinton is ready to train you at home in your spare time. Get his book. Listen to what he has to say. He brings you real opportunity to get into Aviation and cash in on its big future.

My famous course trains you right in your own home—gets you ready for one of the good ground jobs —or cuts many weeks and many dollars from flight instructions. Send for my big free book today.

Don't sit back and envy the men who are in the midst of the romance, adventure and fascination of Aviation. **YOU DON'T HAVE TO.** For right in your own home, in your spare time, I'll give you the training you need to get started in this growing, well-paid industry. Send for my free book. It tells all the facts.

Many Make \$40, \$60, \$75 a Week

Yes, sir. Through the amazingly simple method I have worked out, I can train you at home to fill many well-paid jobs in Aviation. Naturally, before you can fly, you have to take additional instruction in a plane. Even on that instruction I save you time and money. But when you graduate from my course you have the necessary foundation to take up such work as Airport Manager, Metal Worker, Assembler, Wing Doper, Transport Worker, Welder, Instrument Maker, Inspector, Wood Worker, Airport Worker, Mechanic and scores of other well-paid positions. Many of my graduates quickly get into jobs paying \$40, \$60 to \$75 a week. Others, with the additional low cost flying instruction I arrange for, become pilots at \$300 a month or better. Send for my free book now and get the interesting particulars. Learn how I fit you to fill a good job immediately upon graduation.

You Have Many Types of Jobs to Choose From

This simple, fascinating, easy-to-learn course actually covers the ground so thoroughly, my graduates now fill many types of Aviation jobs. At good salaries, too. Read the list of jobs in the center of this page. Check them over carefully. Then remember that they are but a few of the many jobs that Aviation offers the trained man.

Aviation is Growing Fast

Get into Aviation now—when you are still getting in on the ground floor of a new industry—when you have a chance to forge ahead without having to displace lots of older men. Aviation is a young man's industry, where young men earn real money. The president of the biggest air line in the World is only 35 years old. Most famous pilots are in their early thirties, or even younger. It is a young man's industry, which means that there are plenty of opportunities to forge ahead. But just because it is run by young men, don't get the idea that Aviation is a small

Here are just a few of the many well-paid jobs in the fast growing Aviation Industry

ON THE GROUND

- | | |
|------------------------|-------------------|
| Airport Superintendent | Purchasing Agent |
| Instrument Specialist | Aerial Mail Clerk |
| Electrician | Motor Expert |
| Shop Foreman | Radio Operator |
| Hangar Crew Chief | Airplane Mechanic |
| Trainer Manager | Field Work |

IN THE AIR

- | | |
|------------------------|-------------------|
| Air Express Agent | Private Piloting |
| Air Mail Pilot | Weather Observer |
| Aerial Photography | Flight Instructor |
| Airport Manager | Commercial Pilot |
| Test Pilot | Field Manager |
| Aerial Passenger Agent | Transport Pilot |

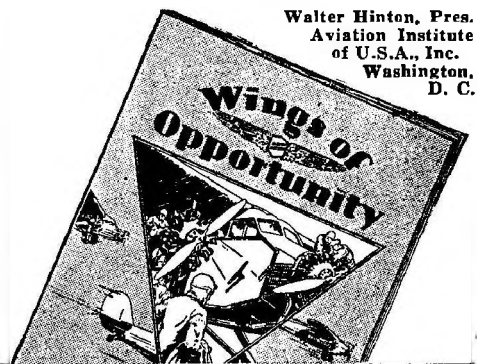
I Have Helped Secure Jobs for Many of My Graduates

Due to my wide-spread connections with aviators, plane manufacturers, airport managers, etc., I am in an especially favorable position to locate jobs for trained men. My Aviation friends know that Hinton-trained men are well qualified to fill any job for which I recommend them.

Send for My Free Book Now

Now is the time to act. Don't sit content with a humdrum job with no future. Act now—to get yourself into Aviation—the industry that is slated to grow into a giant business in the next few years. Get into Aviation. Study at home in your spare time for a well-paid job with a real future. Mail the coupon for my free book today.

Walter Hinton, Pres.
 Aviation Institute
 of U.S.A., Inc.
 Washington,
 D. C.



FREE FLIGHT

"Give her the gun!" You're off! Yes, siree, as soon as you complete my course, I arrange a free flight for you at an accredited air field. It doesn't cost you a penny. It is my graduation present to you.

Mail for my big **FREE** BOOK on **AVIATION NOW!**

These Men Made Good With My Training

Got Good Job at Airport

"I am now working at the Asheville Airport. My work consists of selling tickets, and servicing ships before flight. Mr. Bender, who owns the airport, called at my home after receiving your letter. Thanks very much for writing Mr. Bender."
 —Nick Molnar, Patton, Pa.

\$75 a Week as Instructor

Rebt. N. Dobbins, a Hinton graduate, writes: "I cannot thank you enough for the assistance you gave me in getting my present position. Last week they promoted me to Chief Instructor, at a big salary increase."

Training Gives Quick Results

"I received a call from the manager of a nearby airplane factory, who understood I was taking your Course. I was taking your Course, and asked if I would accept a position as chief mechanic and in his absence, act as manager."
 —Edward F. Dick, 2203 Tuscarawas St., West Canton, Ohio.

Mr. Walter Hinton, President
 Aviation Institute of U. S. A. Inc.
 1115 Connecticut Avenue, Washington, D. C. 935-A

Please send me a Free copy of your book, "Wings of Opportunity," telling all about my opportunities in Aviation and how you will train me at home for them. This does not obligate me in any way.

Name
 (Print clearly)
 Address..... Age.....
 City..... State.....

Claws of the Hawk

A Dark and Threatening Shadow Loomed in the Pacific!

No lights shone out over the Pacific from those Coast towns, and in that desolate, wintry twilight there seemed no living thing. But stealthily, something moved in the darkness—the U. S. *Macon*, engines muffled, on its lonely suicide vigil. For a deep shadow lay upon the silent Coast—the grim, dark threat of war.

DAYLIGHT was fading into the dusk of a cold mid-winter night. In the cities along the Pacific coast, the shadows quickly lengthened, but strangely, no lights shone out in the gloom. For another, deeper shadow lay upon the Coast—the grim, dark threat of war.

The setting sun raced out to sea, leaving the frightened cities, the Fleet and its far-flung scouts, the subs and the winged patrols—until in that desolate, wintry twilight, there seemed no living thing. But stealthily, something moved beneath the massed gray clouds. The *Macon*, engines muffled, was on its lonely suicide vigil.

In the C.O.'s tiny quarters, two men bent over a map, faces gaunt beneath their stubbled beards. Mitchell, the senior, looked up with red-rimmed eyes.

"Three weeks today since their fleet secretly sailed. Why in Heaven's name don't they strike?"

Sutton, the homely Intelligence officer, wearily shook his head.

"They're up to some tricky scheme. You're dealing with Orientals—"

A buzzer sounded. Mitchell answered the interphone, and turned back.

"Radioman called and cut off. Must be getting a message from Flagship."

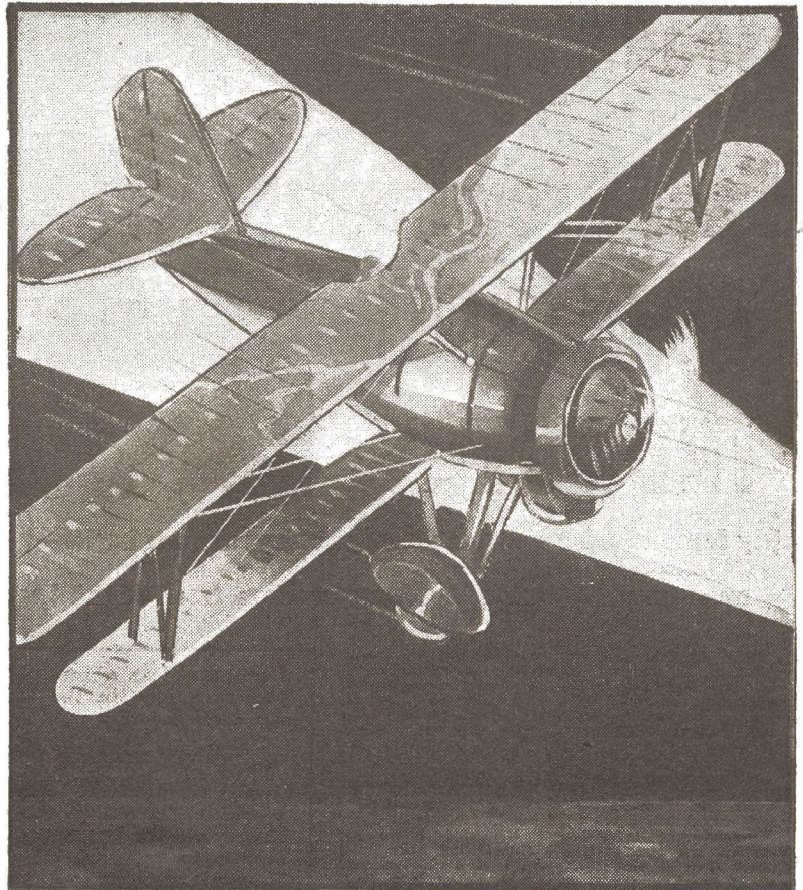
As they went toward the radio cubby, some one opened the catwalk door, aft. Sutton shivered in the icy draft.

"Told you this was no picnic," grunted Mitchell. "Why did you come on this suicide job, anyway?"

A hesitant look came into the bloodshot eyes of the homely lieutenant-commander.

"I was supposed to contact an agent called K-4 when we fuelled at Honolulu. I guess they caught him in Tokio. His number was just about up, poor chap. He'd balked too many foreign spies. Even crossed the great Khiro and—"

"Good God!" Mitchell had pushed open the radio-cubby door. Both he and Sutton halted, transfixed.



Illustrated by Eugene M. Frandzen

The operator's body was slumped crookedly in his chair. His head hung back, eyes bulging in a terrible stare. His face had turned an awful dark, and from his black lips his tongue protruded, thickly.

"Brown!" whispered Mitchell. He sprang inside, shook the man by the shoulders.

"That won't do any good," rapped Sutton. "Ring for first aid!"

Red gashes streaked the operator's throat. From these, blood trickled over a strangely bulging layer of flesh. Sutton leaped to the other side of the chair. The ends of a tight-drawn wire became visible. He hastily began to untwist them. Mitchell jumped around from the phone.

"What is it?" he said tensely.

"He's been garroted, strangled. There's a spy on board!"

Mitchell blanched. He dashed out toward the control room, and in a moment loud-speakers were roaring a warning.

A lantern-jawed hospital steward appeared as Sutton freed the wire from the operator's throat. Sutton glared at him.

"Try to bring him around. Don't stand there staring."

Mitchell returned in a minute. The steward stood up, shaking his head.

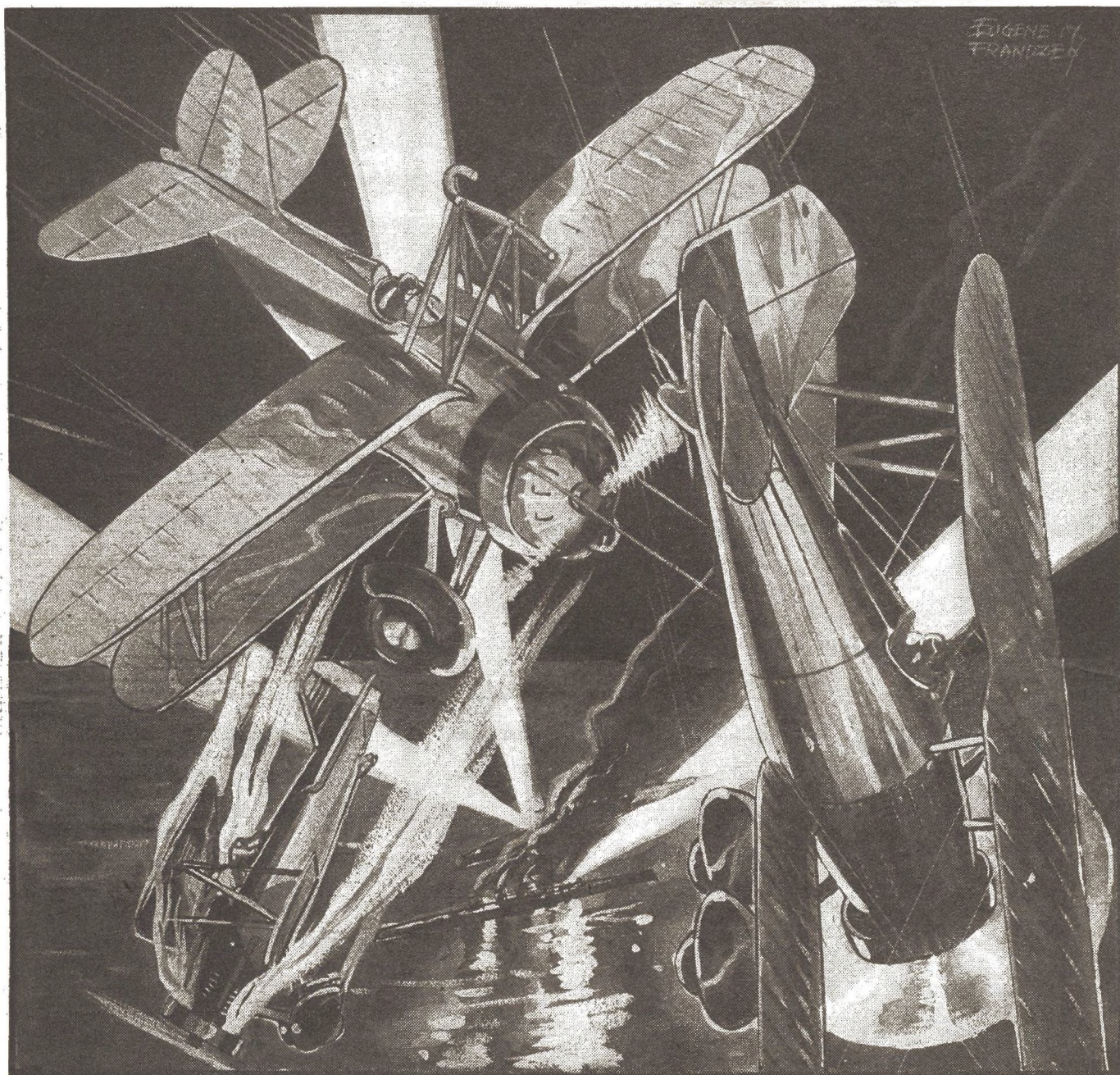
"No use. Whoever did that knew his business."

"Go back to sick bay," ordered the C.O. "Keep still about this." When the man had gone, Mitchell turned a haggard face to Sutton. "I've ordered a search. But how any one could hide—"

THRILLING MODERN AIR NOVEL

By Donald E. Keyhoe

Author of "The Skull Staffel," "The Gallows Ghost," etc.



Hawk caught the diving plane with his tracers, but the third Nakajima lanced down at him.

"Hide!" Sutton stopped his hasty rummaging among papers on the desk. "He won't be hidden. He's one of the crew."

"Impossible! Every man has been double-checked."

"You don't know Khiro," said Sutton, grimly.

"Khiro? The assassin master—the one they called the 'Red Ghost' back in 1930?"

"Right. That fiend could plant a spy in Heaven!"

"Why do you think he's back of this?"

"K-4 warned us that Khiro was working with Japan. Also, garroting is a common device with his agents."

Mitchell looked down at the bloody fingers with which Brown had tried to loosen the wire.

"Poor wretch! But why kill him when we have two other operators?"

"To send a message or—" Sutton seized a blank pad. Impressions of figures were visible. "A code from Fleet! The spy got the original." He sat down, hurriedly deciphered the message. "Can't get all of it, but it's an order to circle at your 5:30 position for—"

Thudding feet sounded outside. An excited lieutenant burst into the room.

"Top observer reports a plane diving through the clouds, sir!"

Mitchell wheeled, but Sutton grasped his arm.

"It's probably this courier pilot who's to hook on at 5:30."

Mitchell looked relieved. The lieutenant was staring at the dead operator. The C.O. gave him no time for questions.

"Keep the gunners on their toes till that plane is

identified. Give orders for the hooking-on crew."

A RELIEF operator was summoned; then Sutton followed the commander to the control room. The *Macon* had dropped away from the clouds and was slowly circling in the twilight. A louder drone sounded above the muted growl of the airship's engines. Then a Curtiss "Sparrow" airship-fighter slanted down in the gloom, its tubular hook-on apparatus plainly distinguishable.

The pilot was flashing a blinker message. Mitchell ordered a signalman to answer. The code answer received, the *Macon* straightened, picked up speed for the contact. The tiny fighter started to swing into position. Suddenly the snarl of a diving plane came from out of the sky. The snarl grew into a roar, and abruptly twin red streaks shot through the dusk. A monoplane screeched down from the west.

"A Mitsubishi fighter!" rasped Mitchell. He spun around. "Full speed, all engines! Stand by water ballast!"

The tiny Curtiss had whipped around swiftly. It hurtled past the cabin, guns flaming at the other plane.

"Damned fool!" grated the C.O. "Nearly hit us." He scooped up a loud-speaker mike, ordered the plane-bay crew to warm up a defense fighter.

The Mitsubishi had charged between the Curtiss and the *Macon*. Swiveled Lewises were blazing from back in the cabin. The Jap plane ripped up and around, hammering a burst at the airship-fighter. The tiny ship zoomed, its Brownings furiously spurting. Straight as an arrow, it lanced for the Mitsubishi.

The Mitsubishi rolled, pitched back in a vertical bank. Again, the *Macon's* gunners loosed a fiery hail. Then the Navy plane darted into their range, and the Lewises were hastily silenced. Engines roaring, the two planes whirled for each other's tail.

Mitchell's fingers closed tensely on Sutton's arm.

"The first battle of the war!" he shouted. "It's come at last."

Sutton did not answer. His fascinated eyes were glued to the whirling ships. Suddenly, the Japanese plane screamed around in a split. Stacks spitting fire, it started to flee. The little fighter was after it in a flash. An exultant yell went up from the men in the *Macon's* cabin. But it died a swift death.

Like lightning, the Mitsubishi came around. The tiny Curtiss tried to follow through, but lost in that hasty turn. A hundred feet from the *Macon*, the Jap ship zoomed mightily. Guns were pounding from half a dozen stations on the huge dirigible. A cone of fire fanged out, closed on the rocketing plane.

For a second or two, the Japanese ship was lost to view from the cabin. Then it reappeared, diving madly. Wings shrieking, it plunged at the tiny fighter. The Navy plane was pivoting erratically, as though the pilot had lost the Jap ship in the gloom.

Like a thunderbolt, the Mitsubishi struck. With a roar, four guns erupted. Four streams of scorching tracer stabbed at the twisting fighter. The Navy ship writhed under that murderous blast. Its left wing started to crumple. Then oily smoke puffed from under its cowl, and the Curtiss began to flame.

A groan was wrenched from the throat of every man in the cabin. As the Mitsubishi hurriedly sheered away, Mitchell leaped to a microphone.

"Get that rat!" he snarled. "Wake up on those guns!"

A pounding din arose. Tracers crisscrossed in the dusk. The Mitsubishi stood on its tail, streaked up into

the night. The guns on top began to chatter fiercely.

The burning Navy plane had twisted off in a dive. Suddenly, there was a violent concussion. The blazing ship disintegrated in a cloud of fire and smoke. Hissing fragments crashed against the cabin. The *Macon's* rigid frames quivered from the explosion.

The rattle of topside guns took on a furious note. Mitchell cut the cabin amplifier into the top forward observer's circuit. A sudden yell blared out.

"They got the plane! He bailed out!"

With a mournful howl, the Mitsubishi plunged past and toward the sea. Gunfire sounded again from the top.

"What's the matter?" Mitchell shouted into the mike. "More Jap ships?"

"No, sir. He's trying to land on the ship."

Mitchell hastily shifted his plug. "Drill that bird—" he started to bellow at the top-gunners.

"Wait!" exclaimed Sutton. "Try to take him alive. We'll make him talk."

A chorus of yells came through the amplifier.

"There he is! Shoot the—"

"Hold it!" bawled Mitchell. "Get that man alive."

A volley of sea-going oaths answered him.

"I said to get him alive! Commander speaking."

In a minute or two there was a growling report.

"Well, we got the butcher, sir."

"Search him and bring him down here," directed the C.O.

HE and Sutton went into the cabin passage. In a few minutes, a scuffling sounded, out on the catwalk. Then two sour-faced gunners appeared, dragging the inert form of the Mitsubishi pilot. His flying coat had been torn open, revealing the uniform of a Nipponese lieutenant. Though he seemed unconscious, his brown face was twisted into a fierce snarl, accentuated by his high cheek bones.

"You didn't report that he was wounded," rapped Mitchell.

"He wasn't, sir," one of the gunners answered gruffly.

"We had a little scrap bringin' him forward. Some o' th' crew was set to heave him off th' catwalk. I guess he got poked a couple o' times."

Mitchell looked suspiciously at the gunner's fist. Sutton knelt by the captive, pulled up the slanting eyelids. Dark eyes were rolled up tightly.

"Guess he's not faking," Sutton commented.

The second gunner planted a heavy boot against the pilot's ribs.

"Here's a better way of finding out, sir."

"That's enough," snapped Mitchell. "One of you get that first-aid steward."

The steward arrived quickly with his medical case. His eyes popped at sight of the prisoner.

"Holy smoke! I thought they were kidding me."

"He's been knocked out," said Mitchell. "Try to snap him out of it." Then he saw the curious faces of crewmen and officers, fore and aft in the passage. "Here, two of you men move him into that nearest room. The rest go back to your posts."

The captive was carried inside, greasy coat trailing.

"Lay him on the floor," cut in Sutton. "That's my bunk."

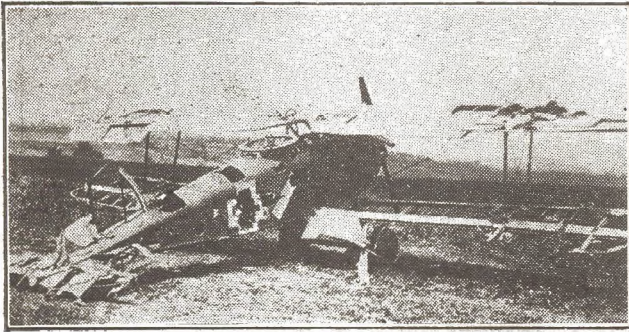
The steward took a vial from his kit, forced the tip between the Mitsubishi pilot's hard-set lips. Mitchell gazed down at the brown face.

"Fierce-looking devil. If they're all that tough—" He stepped back as the steward bumped into him.

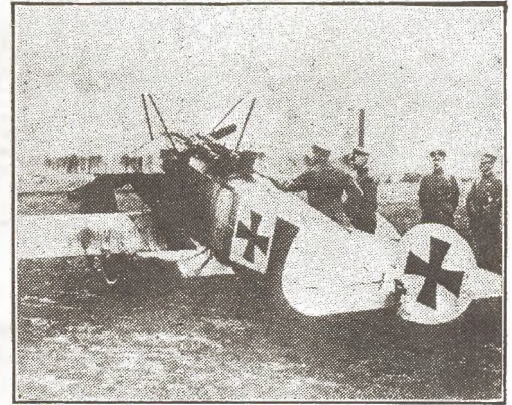
(Continued on page 44)



Snapshots of the War



Souvenir-hunting was a great game during the war. This is what was left of a German Halberstadt two-seater after the boys got through collecting crosses, insignia and numerals. Well, they left the wheels and prop for the experts to work on!

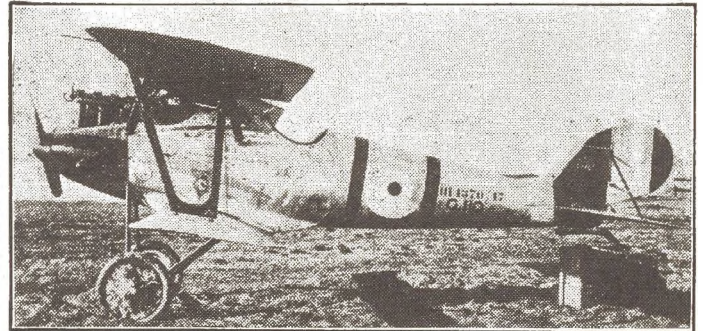


Right: Another picture of Baron von Richthofen's triplane. The Baron is seen under the outer strut, talking to Tony Fokker, who is in the cockpit, checking up on the gun gear. General Von Hoepfner is on the extreme right.

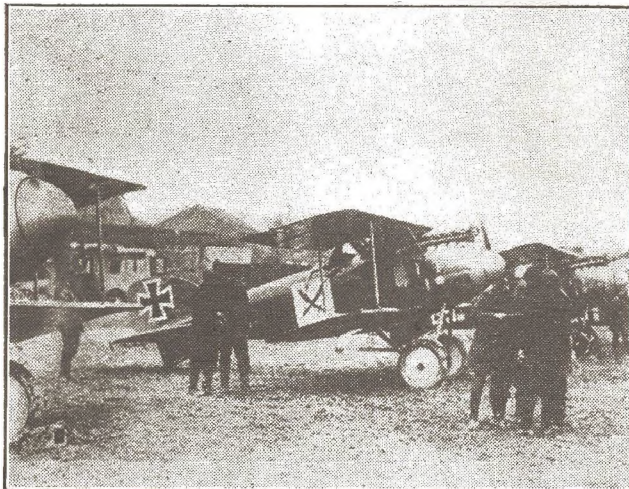
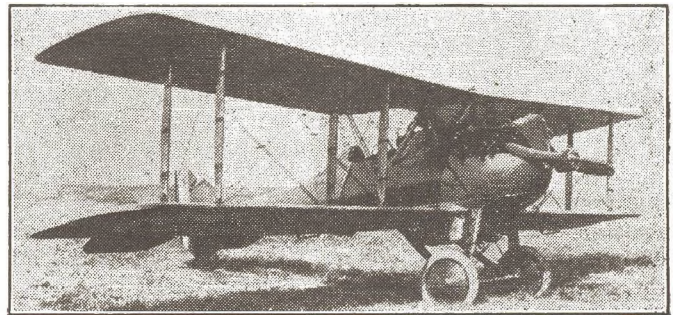


Photo from J. Jay Hirz

A crash that looked bad but was not fatal. A war-time training plane, evidently looking for gas, piled through the roof of a garage, nose first. The pilot escaped injury and landed with the aid of a ladder. The ship had to be dismantled there and taken back to the field in parts on a truck.



Here are two interesting war-time ships. The top one is the well-known Pfalz D-3, a single-seater that at one time threatened the supremacy of the Fokker. British markings were put on after its capture. The ship below is the crack Nieuport-Delage 29, fitted with a 300-h.p. Hisso—a fine fighting ship. Note the circular radiators.



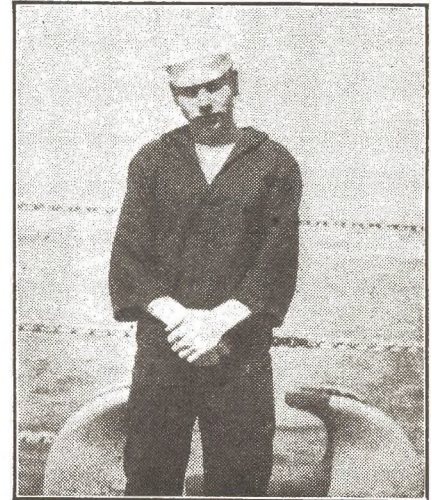
A Turkish squadron of German Albatross D-2's line up before patrol. The pilots are giving their maps a last check, and reading over their orders before climbing into their cockpits. This was taken on the Eastern Front during the World War.



Photo from J. Jay Hirz

The strangest ship in the war! This two-seater Spad carried the gunner's cockpit forward of the propeller. It was hinged at the landing gear and fell forward, to allow mechanics to work on the motor. We hope they had a strong top hook!

Three of the men whose skill and strict attention to duty have saved the lives of our airmen. On the left is B. H. Barker, radio operator at Des Moines, Iowa, who used an ordinary rubber band to keep his signals on the air in a crisis. Center, Joseph Tierny, whose directions by radio saved the life of an Army flyer lost in a snowstorm. Right, Charles Merchant, whose ingenuity rescued two ships in distress.



Lighthouse Keepers of the Sky

WHEN THE RADIO BEAM SPELLS SAFETY!

By Lieutenant H. Latané Lewis, II

Author of "The Trophy No Airman Wanted," "Mounted Police of the Air," etc.

★ ★ ★

A BLINDING winter blizzard was raging outside the airway radio beacon shack perched atop a high peak in the Rocky Mountains near Knight, Wyoming. The wind howled through a ravine and about the sides of the shack like a thing possessed of a devil. Snow and hail swirled against the window panes and piled high in drifts about the corners.

Inside the shack, Charles Merchant, keeper of the isolated station, listened to the monotonous hum of his transmitter, broken occasionally by four dots in rapid succession, which was the identification signal of the Knight station. Weather reports told Merchant that a terrific storm was lashing the earth all along the Rock Springs-Salt Lake sector. He peered through the snow-encrusted windows at trees bent double by the gale and a white curtain of falling snow that blotted out the landscape a short distance away. It would be tough if any planes ran into that tempest.

Just to see if anything was up, Merchant twirled the dials on his receiving set and tuned in on the frequency of the transport company operating over this route. Suddenly his spine stiffened. Through the crackling of static he heard the voice of a pilot somewhere up in that storm, and he was evidently in trouble. As Merchant strained his ears to catch that tense message, he heard the pilot say that his beacon receiver was out of operation and that he could no longer hear the signals that would have led him to safety. It was Pilot Bungee, flying a huge transport westbound on the transcontinental run.

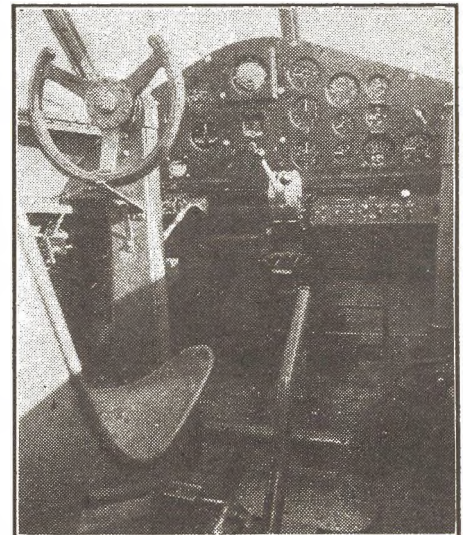
To have attempted to fly out without the beam would almost certainly have meant quick death against the rocky side of a mountain. There was only one ray of hope for him and his precious human cargo. He managed to climb up on top of the storm into the clear space above it, and calculated that his position was ap-

proximately over Porcupine Ridge. He requested, if there were any other plane out of Salt Lake or Rock Springs, to advise them that he was over Porcupine and circling to hold his position. He requested that the other pilot stick to the radio beam and watch out for him as he went over, and that he would follow on the tail of the other plane through the storm.

It was a long chance, but it was the only way he saw to wiggle out of the tight place in which he was caught. As he circled round and round, his gas ran lower and lower. Help would have to arrive soon.

Then Merchant heard the air line station call another plane, with Pilot Rose at the controls, and inform him of Bungee's predicament. Rose immediately raced to the rescue, with his engines revving up at full gun. Rose was sure of his course, for the life-saving beacon signals were coming in strong and clear.

Suddenly there was an



The instrument panel of a typical transport equipped for radio flying. Looks pretty complicated—but every one of those gadgets has its use.

Those towers spell safety to flyers! Below is a typical airways radio weather communication station that sends information to airmen by radio telephone. The two principal antenna towers are 125 feet in height, topped by red obstruction lights as a warning to pilots after dark. Towers are painted in bands of white, yellow and black, so that they can easily be seen in the daytime.

Photo from Dept. of Commerce, Aeronautics Branch



No lighthouse keeper on a desolate rock lives a more lonely life than the operators of some of Uncle Sam's airways radio stations. Tucked away on an isolated ledge in wild, mountainous country, they go about their job—and the radio beacons which they control form a network of invisible sky paths across the United States—a network that spells safety to every airman. Theirs is a great service, and by it countless lives have been saved.

★ ★ ★

ugly rasp, and the signals abruptly ceased. To Merchant's trained ears that sound meant a "grounding effect." He rushed to the range building and inspected the transmitter, but could find nothing wrong. He made his way outside into the teeth of the biting gale to each of the radio towers. He knew that the lives of those persons aboard the ships in distress up above now depended on his ability to get the beacon back into operation, for without its guidance, the planes were floundering helplessly. Anxiously, his eyes scanned every wire, every bolt, every connection.

Soon he located the trouble. A course bending wire had carried away and was grounded in the snow, one end being coiled around a main loop. The only way to remedy the situation was to climb to the top of the tower. How Merchant managed to shin up the dizzy height of that ice-coated tower without a safety belt, while the wind tore at him and the hail pounded him, is not revealed in his own modest account of the affair.

"To go up the pole without a safety belt was hazardous, even had the weather been good," states the plucky radio operator, "and there was none in the station. To waste time looking for something to substitute might have spelled disaster for two planes, for now both Bungee and Rose were depending on the beam to carry them through the storm. The pole was ice-glazed, as were the steps on the side, but I felt that the two pilots up there had no 'safety belts' either, so I shinned up

the pole with an improvised splice and made temporary repairs to suffice until they had cleared the sector."

Those radio dots and dashes were once more beating out their symphony of life for the airmen, and they soon flew to safety. The beacon was out of operation for so short a time that no complaints were ever received about it, and probably those whose lives were saved never knew about the courageous act that kept them from death.

This act is typical of those which are constantly being performed by the keeper of the airways radio beacons. No lighthouse keeper on a desolate rock lives a more lonely life than the operators of some of these stations. Tucked away, perhaps, on an isolated ledge in wild, mountainous country, they go about their job with an unusual devotion to duty. The radio beacons, which are operated by the Bureau of Air Commerce of the Department of Commerce, form a great network of invisible sky paths across the United States.

Not only commercial flyers, but Army and Navy pilots, too, sometimes come in for aid from the Department of Commerce operators. One Army flyer was guided to a safe landing and his life saved by directions from the ground when he became pinched in by a blinding snowstorm over St. Louis last January.

The ceiling was 300 feet, visibility one half mile, and

(Continued on page 78)

Attack from the Stratosphere

Air Battles of the Future. No. 2

THRILLING STORY BEHIND THIS MONTH'S COVER

By C. B. Mayshark



DEATH and destruction from the skies! Raids on the United States mainland by an unknown foe!

Impossible? That's what the arm-chair soldiers say. They see only attack in the form of surface vessels that may try to sneak through the natural defenses. A few with a broader scope of view admit that a few airplanes could take off from a carrier outside New York or Washington. But of course, they say, these planes would be stopped once they got inside the range area of the defensive microphones.

But there is a deadlier air weapon than the ordinary bomber or fighting plane. Let's paint the picture.

Fifty thousand feet above the Gulf Coast, the sunshine is trickling through the clouds in straight lines, bringing life to the farmers and fishermen and merchants on the land and water below. But suddenly something else, mysterious and ominous, is trickling down through the clouds—in straight lines, also. Bombs! And instead of bringing life, they are bringing death and destruction to the people below.

With a shriek, they hurtle into view beneath the lowest strata of clouds, but no mortal force can stop them now. When these bombs hit, dirt, sunshine, and men alike are driven into oblivion, and hysteria and a ghostly fear follow in their deadly wake.

Frantic telephone calls stream out over the wires, and presently the C.O. at Maxwell Field, Montgomery, Alabama, is speaking. Are there any fast two-seaters available? Certainly! Several Curtiss Shrikes have just been sent down from Buffalo. Can they be prepared for action and flown to the coast immediately? Yes, immediately. That is all. Within five minutes three Shrikes rip into the air and head south, and on the grim faces of their pilots and observers is a look of courage and determination.

What are the machines that have been given this assignment?

The Shrikes are considered among the greatest attack ships in the world, and have provided a new design for many other countries to copy. The ship is manufactured by the Curtiss Aeroplane and Motor Company at Buffalo. It is a low-wing, wire-braced machine, carrying a pilot and an observer. The model shown on the cover is the Conqueror-powered job, listed as the A-8. The motor is chemically cooled, and rated at 600 horsepower.

Probably the most interesting feature of this ship is the armament, for it has been stated that it is equal in gun fire to a regiment of infantry. The observer is provided with two high-speed Browning guns. The pilot has the control buttons of four high-calibre guns in his cockpit. These weapons are hidden in the upper portion of the landing wheel cowlings, while in some models an additional high-calibre gun is mounted in the starboard wing root.

On actual attack work, the Shrike carries a special 500-lb. fragmentation bomb hung between the wheels. This is for offensive work against troops, ground activity and transportation.

Some one back at Maxwell has hinted that the attack is being made by a stratosphere machine of some sort. Every pilot is pondering on that statement. They circle over the area pin-pointed for them until they reach 25,000 feet, the ceiling of the new attack ships. They have taken to the oxygen masks 5,000 feet below this sky lane, and still catch no sight of the raider.

Where—and what—is the menace from above?

The stratosphere ship which eludes the Army two-seaters so easily embodies principles of construction which are being employed at the present time in several countries.

There are two details of design in the stratosphere ship which might be alluded to as radical departures from conventional airplane construction. The first to note is the unusual depth to which the undercarriage is slung. The sole purpose of this is to allow an unobstructed radius for the long blades of the propeller when the ship is on the ground. The long-bladed air screw is used because a greater propeller beat is required in the thin air of the stratosphere.

The second feature to note is the comparatively large control surfaces, used because of the low resistance offered by the high-altitude atmosphere. The control surfaces of an ordinary airplane, if it could reach the stratosphere, would be of practically no avail.

The control cabin is absolutely air-tight, thus maintaining a pressure that is equivalent to that of sea level. Oxygen tanks are carried to insure a fresh supply of air at all times. The power plant is a twelve-cylinder, opposed, water-cooled engine, fitted with a super-charger. Difficulty is encountered in cooling an engine at high altitudes. Therefore, the radiators are located outside the metal hull.

The water radiator is on top, and is set in a longitudinal line so as to offer the least resistance. As water circulates through this radiator, it is cooled instantly upon contacting the extremely cold air to be found at great heights. The oil cooling is also accomplished by means of a radiator mounted outside the hull. Swung between the main struts of the undercarriage, this radiator is built so that the broadest surface is facing forward. Resistance offered is practically negligible, however, because of the small overall dimensions. All bombs are carried inside the hull, a trap being opened to emit them.

As the Shrikes speed along at 193 miles an hour to meet this monster, the Army pilots and observers scan the skies with searching eyes. If they must fight a stratosphere ship, they certainly cannot fight it in the stratosphere. With difficulty they can get a few thousand feet higher—but no more. Well, perhaps this strange demon of the air will eventually come down to get observations and pictures. Then they will have their chance.

The Shrikes continue along the coastline for perhaps twenty minutes in a westerly direction toward Mobile—and suddenly the stratosphere ship appears. Tearing down through the clouds at a terrific rate of speed, a long, blue low-wing monoplane seems about to crash into the Army two-seaters. With the speed of a darting snake, the leading Shrike banks to the right, and the observer fires the first shots. But to no avail!

The stratosphere ship has now pulled around and is beginning to climb, with the two-seaters frantically trying to reach it. Suddenly a gun tunnel is lowered from beneath the fuselage of the stratosphere ship, and as it belches tracer, the Shrikes are dispersed like leaves before an autumn wind. As they reassemble, they make one last desperate attempt to reach their adversary—but the height is too great.

What is the answer to this threat? Will it be an armored lighter-than-air ship, or will the anti-aircraft men develop a gun and range-finding equipment to stop it?

Our guess is that we shall have to fight fire with fire, and build stratosphere fighters.

"Why, it's von Snoutz," said Phineas.
"Fancy meetin' you here!"



An Itch in Time

STUDY PALMISTRY WITH PHINEAS IN A MIRTHQUAKE

By Joe Archibald

Author of "Good Haunting!" "Parlez Voodoo," etc.

PHINEAS PINKHAM leaned against the corner of a Frog *estaminet* in Bar-le-Duc, big hands plunged into his pockets which were as empty as a Scotch poor box. Phineas was without a *sou*. The Boonetown jokester was thirsty, very thirsty. Moreover, he had promised to bring Babette a box of Frog bonbons. At the moment, if bonbons had been selling for one *centime* a barrel, Phineas could not have purchased enough to give a bar-fly diabetes.

"It's a pretty pass I have come to," he mumbled to himself. "If I ever shoot the bones with Bump Gillis again, I'll—why, there's Major Garry! Oh-h-h Rufe—er—major! *Voilà!* Over here. Hey-y!"

Major Garry of the Ninth Pursuit Squadron stopped, swore under his breath and then crossed over.

"You would make a good moose-caller, you fathead," he growled at Phineas. "What ails you? Why aren't you in jail?"

"Oh, I have mended my ways," Phineas grinned. "Ah—er—say, uh, I am a little short *ce soir*. If you have

Phineas Pinkham turns palmist and predicts a dark fate for a certain major. But Phineas should have read his own palm first. His fate line would have showed him a bright future—bright like the bottom of a vat of tar!

Illustrated by the Author

a franc or two which ain't workin', would—er—would you trust me till—"

"Ha!" Garry laughed harshly. "I have some francs that're idle, but I'm giving them a job at the next corner. Well, have a good time, Carbuncle! Don't drink too much champagne."

"Awright, fair-weather friend," Phineas sniffed. "I'll find a way to git financed. I hope you're robbed by thugs before the night is over."

Major Garry's gloating laugh died as he entered a Frog oasis.

"An' me spittin' cotton," grumbled the impoverished flyer. "Oh, you wait. No bum kin—" He sidled close to the window of a café. Inside, two officers were seated at a table within view. Amber liquid sparkled in glasses at their elbows. Phineas' salivary glands gurgled.

"Yep, colonel," one of the brass hats was saying, "you must come an' see us when you get back from the gare. Got a fine wife—Etta's her name. Got quite a house in Dubuque."

"What's your business, major?"

"Traveling salesman," the major replied and grinned. "Nope, I don't know any farmers' daughters. My territory is in the corn belt, too. Minnesota, Iowa, Kansas—"

"Well, let's finish this drink," said the colonel. "Then we'll go to see *Madame La Luna*—greatest clairvoyant in France. Must let her read your palm, major. You'll be astonished. Remarkable, I assure you."

"The saps," grunted Phineas, "squanderin' *argent* when I'm practically a pauper. Well—"

Crash! Blam-m! Bla-a-a-am! C-r-r-r-ash!

"Gothas!" yowled Phineas and headed for cover. "The bums must have had them props wrapped in blankets." Whistles blew and lights went out.

"Boche! Boche!" yelled everyone hysterically.

"As if I didn't know it," yipped Phineas as he plunged in through a doorway. He bumped into some one who was on the way out and they merged for the moment in a scrambled heap.

"*Nom de Dieu! Sacré!*" a feminine voice shrieked, and Phineas spun sidewise and sprawled over a couch. He plowed his way underneath it as two more bombs made the town shiver. In five minutes the town was as quiet as a church on Monday morning. Phineas crawled out and groped his way around. Investigating fingers drew a match from his pocket, and he scratched it against his pant leg.

"Where am I?" he gulped. "I know I didn't run as far as Turkey."

The walls of the little room were of cloth, and the cloth was covered with crescents and stars. There was a small table, also draped with green cloth, and behind it a chair and a big crystal ball. On a clothes-tree close to it were several multi-colored garments.

"Huh," Phineas laughed as he lighted a candle on the table, "it must be the palmist's joint. Well, huh—I—er—I wonder how long she'll be gone. I wonder—well, I'm desperate an'—"

No sooner had Phineas regaled himself in the flowing robes of the clairvoyant than he heard voices outside the door.

"Huh, we won't let an air raid get us, eh, major?"

"I should say not," was the response.

"Haw-w-w, come into my parlor, says the spider to the fly." Phineas fastened the strange-looking cap and veil around his head and sat down behind the table.

"Evening, *madame*," said the Brass Hats, making elaborate bows.

"*Bon soir*," Phineas replied in an admirable falsetto. "*Que voulez vooze, ce soir? Readez ze pairm, oui? Twenty-five francs, s'il vooze plaise!*"

"You first, major," said the colonel. "I'll listen."

The major seated himself and held out his palm. Phineas' hand, wrapped in part of his garment, gripped it. His head bent over it.

"Ah—ze m'soor, he ees what you call ze selling *homme* who have travel, *n'est ce pas?*"

"Astonishing!" the major grunted.

"I see her ze mam'selle who she leeve in D-Dubuque, *non?*" Phineas went on in his laborious soprano. "Ze majaire, he ees ze lady's man, *non?* Ah-h-h, ze *nom*

of ze mam'selle she ees mabbe Etta, *non?* Ah I see her. She cannot wait unteel you have come back. Her husband, like you tell her wan time, he ees ze fathead, *non?*"

"Uh—er—" objected the major, "this is a mistake. Ah—er—"

"Oh, is that so?" howled the colonel, jumping to his feet. "Traveling salesman, huh? I'm a fathead—well, take that, you wife-stealer! And that!"

"Hit me, will you?" shouted the major, bouncing back from the wall. "You big hunk of cheese!" Ker-whop!

"Adoo," grinned Phineas and headed for the door. Some one was blocking it up.

"What ees thees?" yipped *Madame La Luna* herself. "Who ees eet the impostair, *non? Cochon!*"

"I'm in a hurry," hooted Phineas. "You don't know how much."

"Cheated, by cripes!" thundered the colonel. "After him, major."

Three minutes later, Phineas Pinkham, trying to cover up the fact that he was out of breath, barged into a café and walked up to the bar.

"Veet, veet, a jigger of brandy," he barked at the tender. "Then wrap me up a whole bottle of coneyac an'—"

He planked down some francs and looked around him. Two eyes, as hard as flint, bored into him.

"Oh, h'lo," he grinned. "Y'see, I got financed, major. Ha, where there's a will—"

His eyes widened as they spotted two husky figures right outside the door. One was examining something he held in his hand.

"We'll try this one first, major." sputtered one. "This hat—"

Phineas clamped a hand to his head. Nothing but a shock of brick-red hair came in contact with his fingers.

"I—er—excuse me," he said to Garrity hastily, "I—er—feel a headache comin' on. Which is the back way out, *garçon?* Never mind, I'll find it myself. Don't worry."

"Come back here, you big fat-head," Garrity stormed. "What've you done now? You—"

"Bum sore," Phineas yelped and was gone.

IT took the Boonetown miracle man two hours to reach the drome on foot, since he had decided upon a wide detour. Bump Gillis eyed him askance as he entered their hut.

"Well, Carbuncle, how good are you at wheelin' rocks, huh?" was Bump's enigmatic greeting. "They got a lot of hills in Blois that only a goat can stick to. You can see I've been collectin' your things into a bunch."

"Did they bring me my hat?"

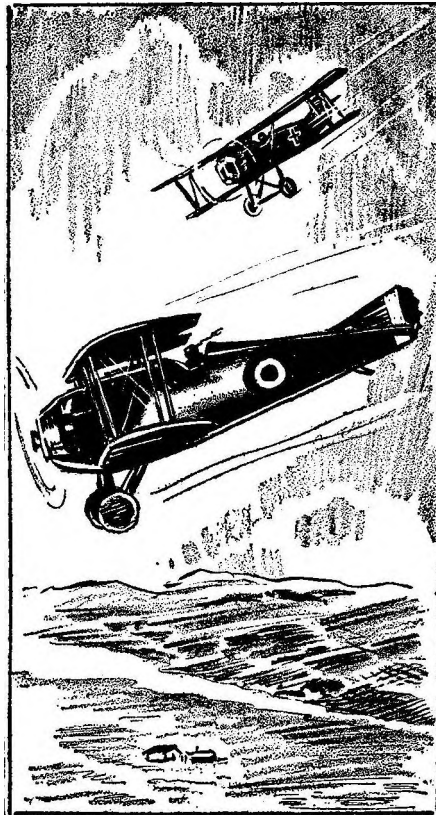
queried Phineas. "They got nothin' on me. I just lost it an'—"

"It is an important hat right now," yawned Bump. "Three M.P.'s escorted it here."

"Well, I'll go right over now and make a clean breast of it," the culprit decided. "When you own up an' say you're sorry, they get lenient, don't they?"

"Yeah," replied Bump. "Ha, ha! It is twenty years instead of life."

"I've got a defense," insisted Phineas as he went out. "No jury would convict me. Haw-w-w-w!" He headed



"Well, it ain't my day," Phineas gulped.

for the big Frog farmhouse and swung the door open boldly.

"H'lo, bums!" he grinned at the open-mouthed pilots. "No, I will not give you an interview until I come out. Haw-w-w!" The door slammed behind him.

Major Garrity's head snapped up. His lower jaw began to move away from his face until he looked like something that lived in a cave.

"Huh, I bet you just couldn't wait to see me," Phineas shoved out fast. "Uh—a funny thing happened. The last I remember is divin' into a door when them bombs went off. I just come to myself about a mile from here. Now what do you think could've happened, major, huh? Why—er—is that my hat on the desk? Uh—er—I giss I must've been knocked out of my senses, huh?"

The Old Man got up out of his chair. "You fresh, cock-eyed liar!" he bellowed. "You know damned well you remember everything. You incited officers to attack each other, got money under false pretenses. Empty out your pockets, you—you—"

"Why—er—" said Phineas as he pulled out some currency, "now how did that git there? Dough, huh? That's my luck. I wisht I'd known I had it when I was in Bar-le-Duc, as Babette will be as mad as hell at me for not buyin' them bonbons. I wish you would tell me what happened. I still feel a little faint an'—" The trickster passed a hand over his brow. "Maybe a week in Paree—"

Captain Howell and the other pilots in the big room outside shuddered as something hit the door of Wings.

"The Old Man better save enough of the fathead for the court-martial," commented the flight leader. "The Brass Hats'll git sore."

The door burst open. Phineas Pinkham flew through it toward the outer door.

"I'll report you!" he yelled back at Garrity. "Throw-in' a chair at a guy who should be a patient in a hospital. I—"

The Old Man stood glowering at the buzzards when Phineas had fled. "You know what his alibi is?" he yowled, and then ripped off a bushel of words. "And the hell of it is, I bet he gets away with it. Shell-shocked, he says. Didn't know—didn't remember—by cripes, you think it's funny, huh? You're a bunch of—"

"Pardon us," gasped Howell. "We just got over listening to a funny story. Ha, ha! It seems there were two travelin' salesmen an'—"

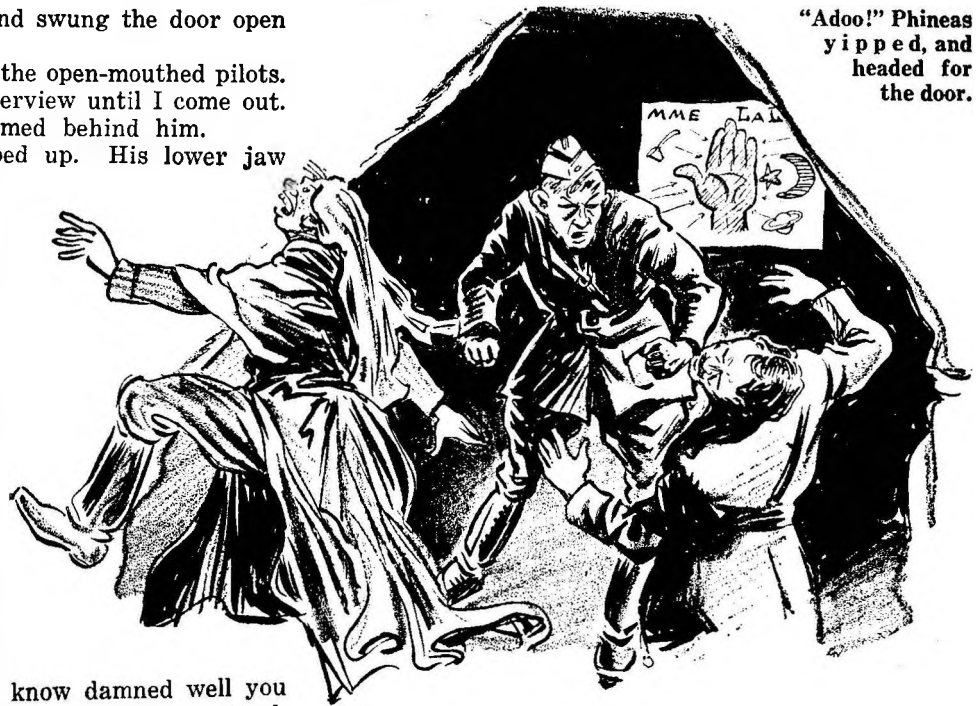
"Nuts!" shouted the Old Man, and slammed the door of Wings.

Morning found Phineas Pinkham taking his regular place in Howell's flight. The Brass Hats had made it plain to Garrity that Pinkham should have every opportunity of getting himself killed to save time and expense at Chaumont. If by chance he had survived by the time the judge advocate was ready to listen to him, then all well and good.

There was something funny about the Pinkham Spad as it stood on the line. Just over the guns he had constructed a pair of mirrors.

"Are you goin' to shave on the way?" Bump Gillis wanted to know. "You git nuttier by the minute."

"Where would we have got electricity if Ben Franklin hadn't had a key, huh?" Phineas retorted. "You bums don't have any vision."



"Adoo!" Phineas yipped, and headed for the door.

The flight leader, Howell, growled as he watched his chief pain-in-the-neck yank a couple of strings. The mirrors moved. Captain Howell shook his head, swore and climbed into his own ship.

It was a day when the *Rittmeister* von Schnoutz felt very much like soaring into the blue. Herr von Schnoutz, a breakfast of pig hocks, apple strudel and mashed turnips under his belt, was cockier than was Napoleon when the Little Corporal was leading the league.

"Today we chase idt der Yangkee troops vhat cooms oop," he chuckled to himself. "Ach, it takes vun var to make *ein Mann* feel hiss oats. Yah—Gott!" Directly ahead and just below him rocked a flight of Spads. The Yankee leader nosed up as von Schnoutz signaled from the coaching lines.

"There's the bum," Phineas grinned. "Now to experiment, haw-w!" He zoomed with the rest of the flight, was within striking distance when he threw his sky chariot into a loop. When he had straightened out again, an Albatross was chasing him. Phineas, with his back toward the sun, jerked at the mirrors. A dazzling flash blinded him. Tears came to his eyes under the glass goggles. He sneezed. Bullets came thicker than flies around a swill cart.

In desperation, the Yankee magician went into a dizzy sideslip. When he came out of it, his motor sounded like a horse with the heaves. A wing tip wobbled like the wet brim of a old felt hat in a high wind. There was nothing to do but head for Garrity's front lawn, and there was an even chance that Phineas would not make it.

Nevertheless, the Boonetown hero landed his Spad not three yards from where Old Man Garrity stood holding converse with Sergeant Casey. He got out and looked ruefully at the mirrors. A Jerry bullet had smacked one clean of any vestige of glass.

"Seven years' bad luck," muttered the experimenter. "Oh, well—"

"You were washed up early," commented the C. O. out of the side of his mouth. "That Spad looks like a union suit."

"Even Julius Caesar didn't bat a thousand per cent," rejoined Phineas with a groan, and he sat down on the ground to wait for the survivors to come in.

When the flight returned, Captain Howell and Bump Gillis walked over to the disconsolate flyer.

"Marvelous invention!" enthused the latter, grinning broadly. "The next thing you want to do is invent a gun that shoots back through you an' at the Heinies. Ha, ha, did I laugh!"

"So you thought you'd do it with mirrors, huh?" stormed Major Garrity as he took one look at the Spad. "The next time you doctor up one of those crates, you lose a month's pay. You'd better go to your hut. Catherine the Great wants to see you."

"Have your fun," snapped Phineas. "But I'll show you bums. You just wait!"

There was a very hot sun burning down on the drome all day. A big ray hit the Pinkham mirror and caromed off it as Sergeant Casey and his grease monkeys labored over the punctured Pinkham plane.

"How a guy kin break up so many ships an' have all his ribs left is beyond me," growled Casey. "It looks like he ran into a concrete mixer."

THINGS began to happen as the afternoon grew old. Ground hogs began to police up the flying field. Bump Gillis decided to shave. A carload of Brass Hats came to see the Old Man. Their faces were bright and sunny like the bottom of a tar vat. Into the big house they barged, and on into the orderly room.

"Afternoon," one of them greeted the C.O. "Nice day, what?"

"It was until you came in," replied Garrity irritably. "You never breeze over unless it's with bad news. You remind me of a guy I used to know. Every time something terrible happened, they'd send him to break the news to the loved ones. And what fun he got out of it!"

"You're not here to question orders, Garrity," the human pike staff snorted. "This is serious business. Why is it that when we want a Heinie railroad train bombed, we can't get it done, eh?"

"Maybe the Germans don't let us," the Old Man offered. "After all, we would get sore if a Jerry smashed up our five-fifteens, wouldn't we? Well, spit it out, colonel. What's the job?"

"The Jerries are bringing ammunition up to the rail center at Conflans. Shells, grenades, machine-gun fodder and all that. If we could knock off one of those trains, I wager we'd wash out two days of Heinie activity. Observation ships have tried it. Too sluggish. Combat ships could do it, Garrity. String bombs underneath. Three to a ship. Try it tomorrow. G.H.Q. is getting tired of waiting for the Air Force to warrant its being here in France. That is all. Combat ships tomorrow over Conflans. Let's get results."

"It's a dead cinch," Garrity gritted. "It's a cinch some buzzards'll be dead as mackerels this time tomorrow. Ha, ha, come over an' join in the fun!"

"No sense of humor, have they?" Phineas grinned in at the C.O. when the Brass Hats went out. "They were swearing somethin' fierce. I hope you'll ask for volunteers, as this gare is irkin' me lately an'—huh, what's that?"

A siren shrieked outside. Major Garrity and Phineas Pinkham hotfooted it out. There was a blaze over by the ammo shed. Groundhogs were running around like ants kicked out of a hill.

"Fire, fire!" yowled Phineas. "Who set it?"

"You did, you fool!" cracked a voice. It was Casey's. "That sun was shinin' on the mirror on that Spad an' it lit up that rubbish the groundmen raked against the side of the shed. You—"

"I want him busted, sir," Phineas yipped at Garrity. "No noncom kin insult me like that an' git—"

"That's what you think," bellowed the Old Man. "You jughead! You could sit on top of the Alps an' cause a shipwreck in the China Sea. I'll bust you plenty for this. You—hey, hurry up with that water!"

"Huh," grunted Phineas, as he walked to the Spad. "With mirrors, huh? Well, maybe—there's a way."

Just then he caught sight of Bump Gillis jumping around over by the hut. Bump was clawing at his face and howling like a shriek owl.

"Did you get burnt?" the major tossed out as he ran over. "Maybe you rammed your head into the fire to see what caused it, huh?"

"It itches," hollered Bump. "I got somethin'. Git a medico. Cr-r-r-ripes!"

"What is that powder you got on your face?" queried Phineas.

"Talcum, you horseface. what d'ya think it is—soft

coal?"

"I bet I know," grinned the knowing Pinkham, and went into their hut. Several moments later, he shoved his head out. "Haw-w-w-w-w!" came his raucous guffaw. "It's that new itch powder I sent for. I put it in a empty talcum box. I should think you would buy your own toilet articles, Bump Gillis! Haw-w-w-w! It's some itch, huh? I saw it git on a horse once an' the nag ran ten miles to jump in a millpond. Oh, boys, things are pickin' up!"

They were, indeed. Bump Gillis picked up a rock and was on the point of heaving it when it slipped from his grasp, described a parabola through the ozone and conked Major Garrity on the head.

The personnel of the Ninth had quite a time putting out the fire, uncrossing the Old Man's eyes and taking the gun out of Bump Gillis' hand. Phineas sat in the doorway of his hut, applauding the efforts.

"The first guy who grabs some bombs an' strings them under a Spad is Pinkham!" Garrity screeched as his marbles returned. "Then Gillis. I'll show them two wiseheimers!"

"If you don't stop threatenin' me, Bump," Phineas hollered, "I won't tell you what'll make that face of yours stop itchin'. But you have got to say 'please.'"

At nine o'clock the next morning, Bump Gillis and Phineas Pinkham stood close to their Spads as Major Garrity gave them final instructions and a small map. Phineas took a big shaving mirror out of his pocket and held it up in front of his freckled face. With one

(Continued on page 72)



"Haw-w-w! I'm among friends, huh?"

Fighters of Four Nations

Britain's Navy punch! A grim Whitehead torpedo being loaded on a Blackburn Ripon torpedo-carrier. This machine is a two-seater powered with a 530-h.p. Napier "Lion" engine. It has a top speed of 126 miles per hour, fully loaded. The retracting radiator, wing slots and the torpedo-carrying "crutch" are interesting features of this ship. The wings fold for stowage aboard the aircraft carriers. The observer has a Fairey high-speed gun mounting in the rear, and the pilot is provided with two Vickers guns. There's armament for you!

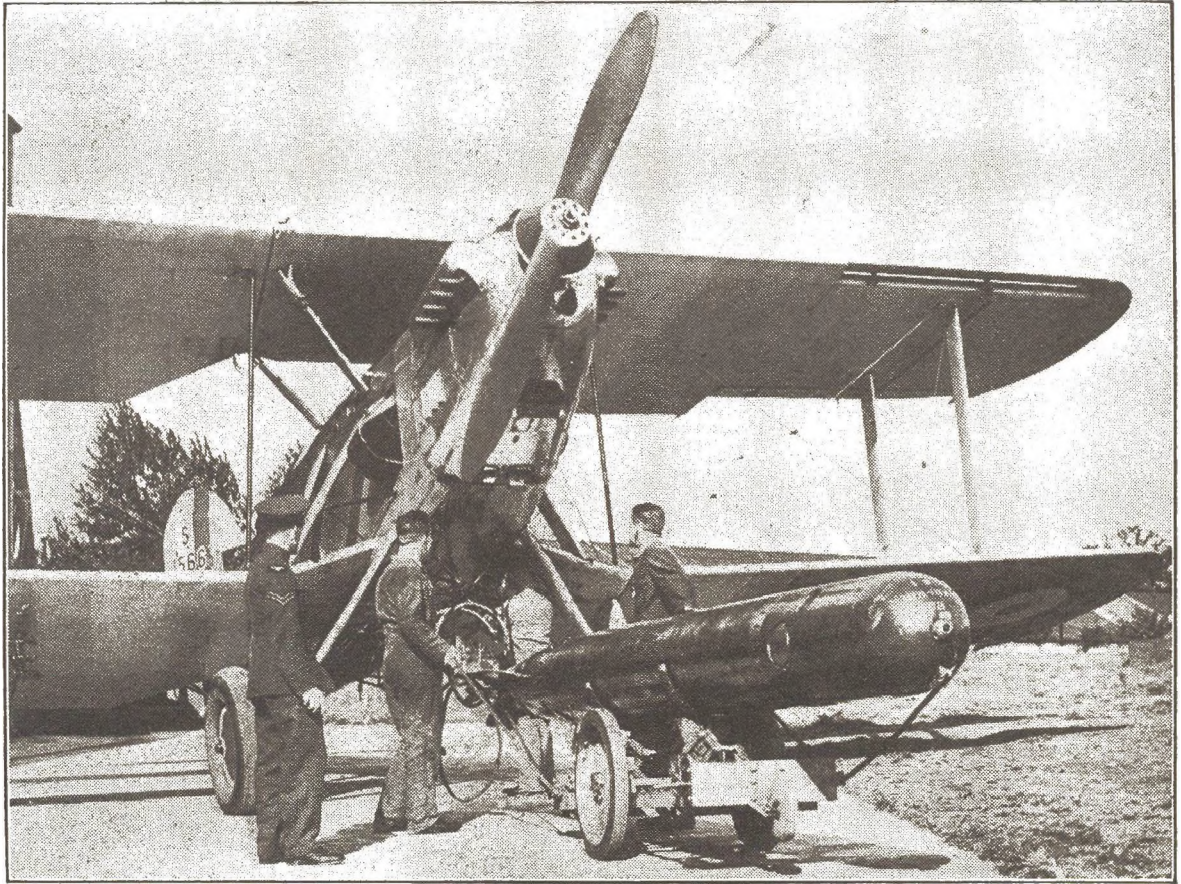
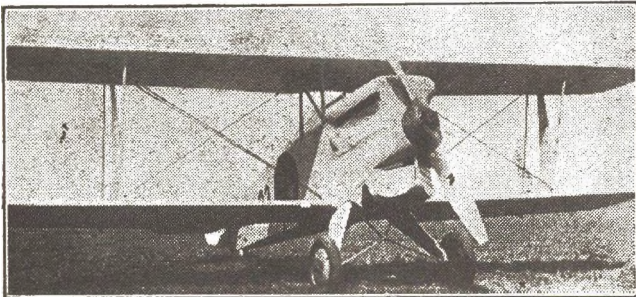
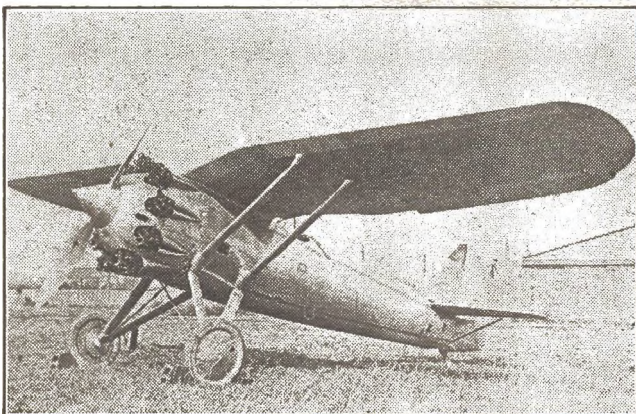


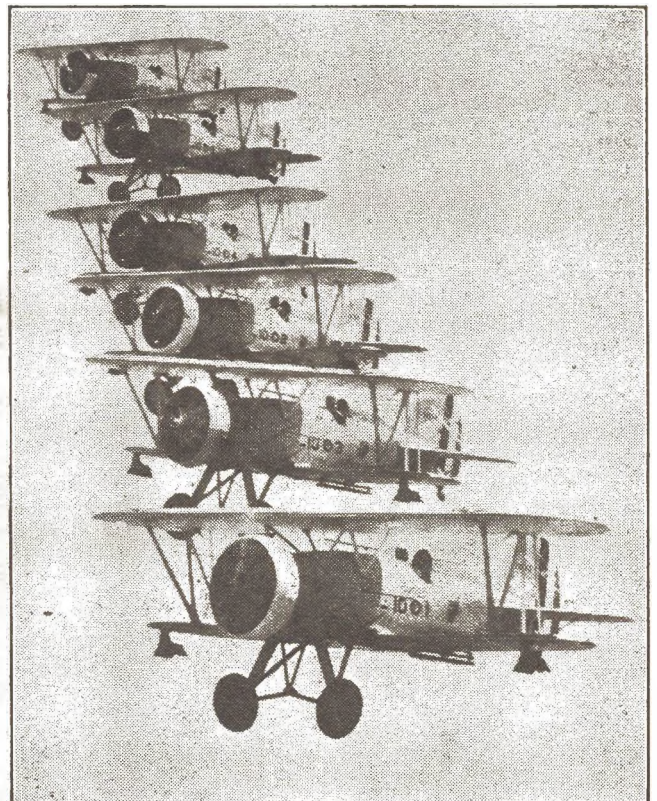
Photo from the Soihelman Syndicate



Japan's greatest air threat—the Kawasaki 92 fighter, a single-seater of unusual merit. This machine has a top speed of 205 m.p.h. and climbs to 16,400 ft. in nine minutes. The power plant is a 450-h.p. Kawasaki-made B.M.W. A wicked baby!



Poland's answer to high speed and fighting power. This is the P.Z.L. "P 11" fighter, said to do 213 m.p.h. It is made in various types, depending on the engine used. Flap-gear control and tail-plane adjustment are carried, and the equipment includes all the latest military material, fire-extinguishers, and fuel tanks that may be dropped in an emergency.



Official Photograph U. S. Navy

Uncle Sam's fighters in a right echelon formation, literally riding each other's wings. These are the famous Boeing F4B-4 fighters. They are listed in the 200-mile-an-hour class and are considered among the world's finest single-seaters.

At Suicide Pass

AS the Spad drew to an idling halt before the deadline of the 39th Observation Squadron, the pilots and mechanics loitering about the mouth of the hangars cast sullen, suspicious glances at its crippled pilot.

He was a small man in height, but he weighed a hundred and ninety-seven pounds and was broad across the shoulders. His face was hard, with a jaw as stubborn as a bulldog's.

He walked with a decided limp. One leg was much shorter than the other, and the leather on the boot-sole of this was much thicker. He swung the weighted boot like the pendulum of a giant clock, but for all its awkwardness, he moved with great speed.

He strode up to the nearest group of pilots. "My name is Jones," he announced. "Shipped here on relief. Where'll I find the C.O.?"

A sigh of relief escaped the pilots. The tension that had existed since the landing of the new pilot snapped instantly. And with grins of relief, several returned to a crap game that had been interrupted.

"In his quarters behind hangar three," a lieutenant Thompson replied. "But take my tip, Jones, and don't ever move in on a squadron like that again. Especially one like this, where the nerves of the pilots are none too good." A shrug and a good-natured laugh escaped him before he continued.

"You gave us a scare here. There have been rumors that a Colonel 'Boomerang' Conners is going to hop up here to take command. And we don't like the idea. This squadron is for the Old Man a hundred per cent, and if that Boomerang thinks—"

"Old Man?" broke in Jones.

"Yeah, the C.O., Major Ayres. He's old and white-haired, but square as they come. And it isn't his fault about all the deaths in this squadron lately. He couldn't help it if the Huns invented some kind of incendiary ray that fires crates—"

"A ray that fires crates?" interrupted Jones, doubt rising in his voice.

"Well, if it isn't that, you figure it out for us," Thompson challenged. His smooth, ruddy skin reddened. "There have been twenty-one deaths in two weeks. Up to those weeks, we had a record that's unbeatable. Then G.H.Q. sent through orders to take pictures of what's behind Hills 604 and 319. They wanted to know just what's what out there—and the trouble started." He paused, shaking his head.

"Our men went—but not one returned. One, two, three—on up to twenty-one crates—Camels, Spads, S.E.5's. And there are a lot of strange stories running loose."

"What kind of stories?"

"Stories of strange fires. Without a crate in the sky, with no Archie bopping, and without any kind of shell fire—those Boche are setting fire to our crates!"

"Impossible."

"Oh, yeah?" Thompson snorted. "Well, if you had counted twenty-one crates going down that way, as we

By Edwards A. Dorcet

Author of "The Cloud Clicker," etc.

They called him "Boomerang" Conners—because he always came back. And they sent him on a horror trail to Suicide Pass, where twenty-five men had gone down to a blazing death. But at Suicide Pass Boomerang faced a new challenge—for from that graveyard of pilots there was no return.

did, it doesn't sound so impossible. I tell you, those Krauts have developed an incendiary ray!" he continued. "We never know who is going over Suicide Pass next. It's a patrol from which there's no return.

"And with nerves as ragged as ours, when we get to thinking of this Boomerang Conners taking command of the squadron, we get mad, eh, Wilson?" He turned to a watching pilot.

Sergeant Wilson nodded. He was a blond giant, with large, blue eyes. "Damned mad," he said soberly. "N o b o d y double-crosses Major Ayres and gets away with it. The major, he's one fine man,

Jones. And no Boomerang Conners, colonel or not, can bring his grudge to this squadron."

Jones' features wrinkled. "Grudge?" he asked.

"Sure," Thompson explained. "This Colonel Boomerang Conners didn't want Major Ayres sent up here. He said that Major Ayres was too old for such a post—that he couldn't control his men. But G.H.Q. sent him, anyway, and Boomerang probably hasn't forgotten it.

"For a while Major Ayres made a fine record. Then things went snap—when that incendiary ray cut loose. So we figure the colonel will look us over and report, 'I told you so' to G.H.Q."

"And if he does," the blond giant interrupted, "I'm going to tell him something—with these." He held out a pair of fists that were the size of hams.

"In other words, this Boomerang isn't likely to be popular at this squadron." Jones smiled. He thanked Thompson for his information and started over the oily ground between hangars two and three.

As he did, a sharp-featured lieutenant pushed forward. He wore engineer's chevrons and was head of the photograph and chemistry department of the squadron. His eyes were fish-round and glary.

"Boomerang had quite a talk with you boys," he said, pointedly. "You ought to be quite friendly by now."

Wilson's eyes blazed fire. His teeth snapped like clamps. "Was—was that Boomerang Conners?" he stammered in surprise.

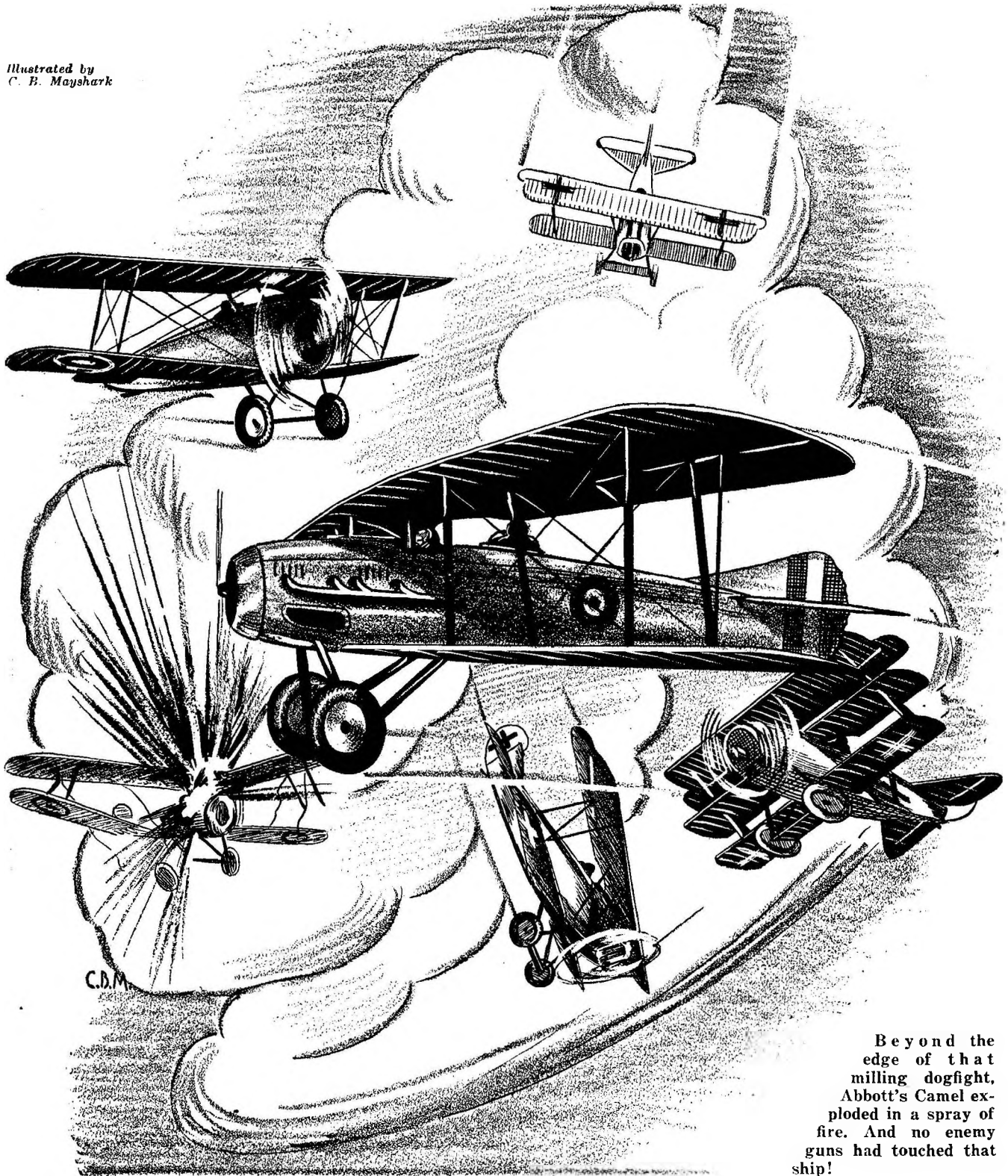
"Didn't he tell you?" the grinning Fisher asked in mock astonishment. "Well, you'll find out when he takes command. He's plenty tough—even for you, Wilson."

Wilson said nothing, but stared thoughtfully after the limping figure . . .

All eyes were on Boomerang Conners that night at mess. He felt them burning into him accusingly. He would rather have remained incognito for several days—at least until he learned a few things about the squadron. But the cat was out of the bag now, so he took the scorching glances calmly and wordlessly, feeling like an outlaw.

When four days had passed, and Boomerang Conners failed to go near Suicide Pass, the squadron grew uneasy. With dead certainty, the squadron grew to believe he was there only for the purpose of spiting and ousting Major Ayres. And Wilson's big jaw showed new grimness. No one, he was determined, would work un-

Illustrated by
C. B. Mayshark



Beyond the edge of that milling dogfight, Abbott's Camel exploded in a spray of fire. And no enemy guns had touched that ship!

derhanded on this squadron and get away with it. No, not even a colonel.

During those four days, two more attempts were made to break through the enigma of Suicide Pass. Lieutenants Chess and Williams went to their graves on the flats beyond the Pass. Both went down in flames, mysterious flames. No Boche crate was in the sky at the time, and there were no Archie bursts, no exploding shells—just fire, with both crates almost engulfed by it.

Meanwhile, Major Ayres kept to himself. He mingled less and less with the men. The two new casualties hung heavily over him, and the presence of Colonel Boomerang Conners could mean but one thing—the end of Major Ayres' service.

A climax came on the afternoon of the fourth day. The sun sank in a blaze of rioting glory, casting grotesque shadows over the tarmac. Boomerang sat in the yawning doorway of a great hangar, an unlit pipe draped from his mouth.

He had been watching Lieutenant Fisher fixing the camera boxes and rigging. He didn't like Fisher, though he didn't know why. But his dislike for Fisher would probably never come to a fight, as Wilson's hatred for him eventually would.

A man stalked up to him. It was Thompson. "Colonel, you—" he began.

"Boomerang to everybody on this squadron," Conners

(Continued on page 64)

The Flying Arsenal

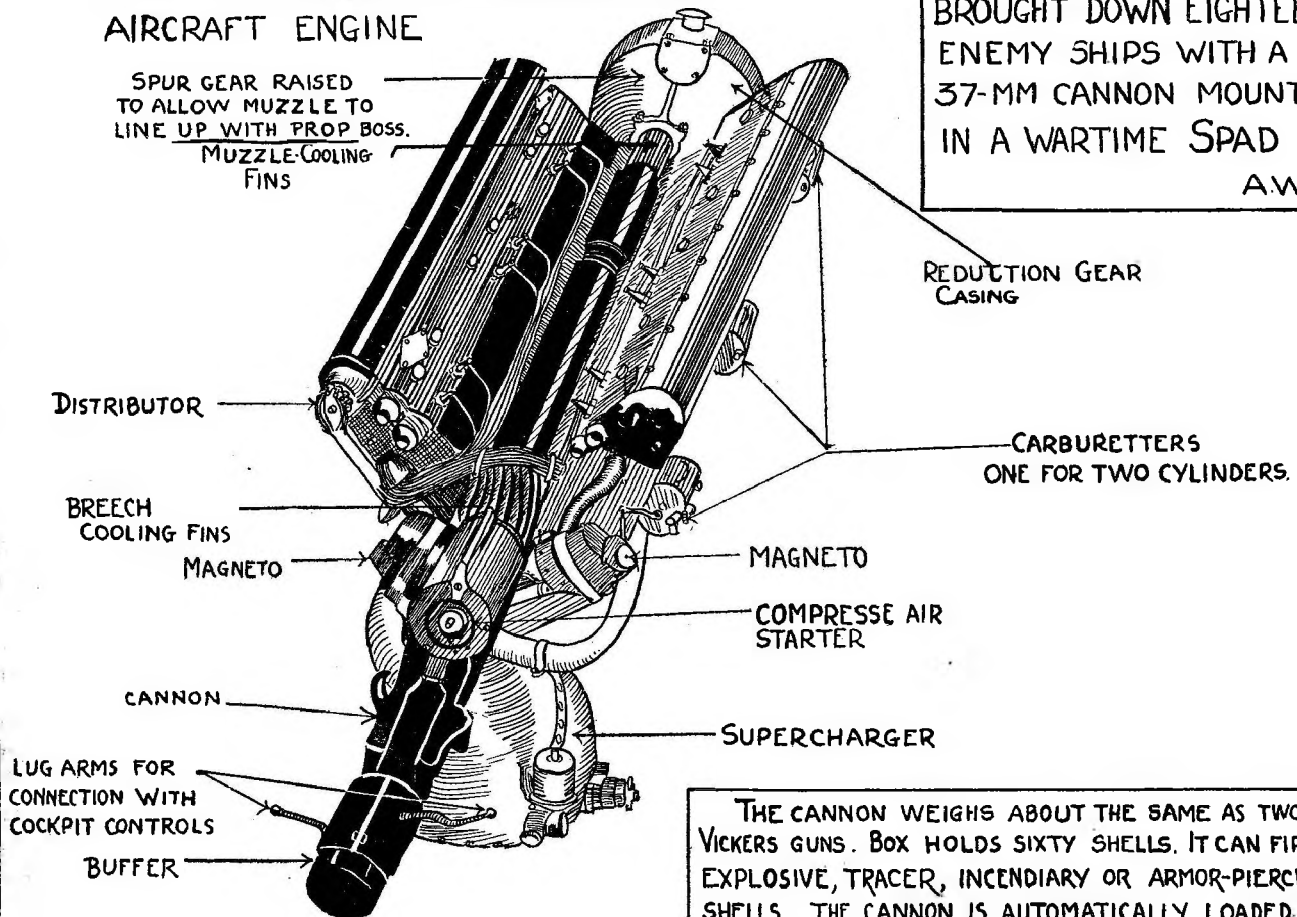
HISPANO-SUIZA MOTOR CANNON

FRANCE'S LATEST AIR WEAPON
A 20-MM CANNON BUILT DIRECTLY
INTO A 775 H.P. 12-CYLS HISPANO-SUIZA
AIRCRAFT ENGINE

FACT, NOT FANCY.

RENE FONCK, THE
ALLIED ACE OF ACES
BROUGHT DOWN EIGHTEEN
ENEMY SHIPS WITH A
37-MM CANNON MOUNTED
IN A WARTIME SPAD

A.W.

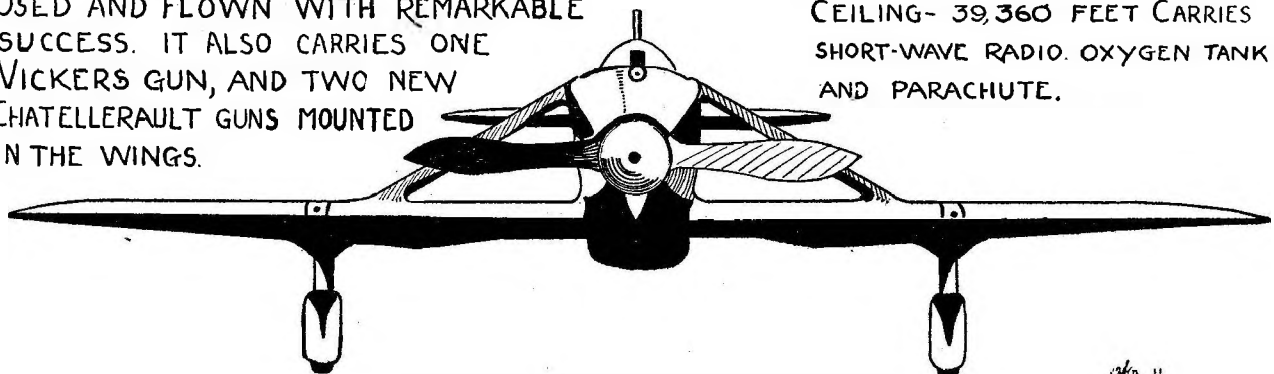


THE CANNON WEIGHS ABOUT THE SAME AS TWO VICKERS GUNS. BOX HOLDS SIXTY SHELLS. IT CAN FIRE EXPLOSIVE, TRACER, INCENDIARY OR ARMOR-PIERCING SHELLS. THE CANNON IS AUTOMATICALLY LOADED BY THE COMPRESSED AIR DEVICE WHICH ALSO OPERATES THE WHEEL BRAKES, INFLATES TIRES AND STARTS THE MOTOR.

MORANE-SAULNIER 325.C1 FIGHTER

ON WHICH THIS HISPO-CANNON HAS BEEN
USED AND FLOWN WITH REMARKABLE
SUCCESS. IT ALSO CARRIES ONE
VICKERS GUN, AND TWO NEW
CHATELLERAULT GUNS MOUNTED
IN THE WINGS.

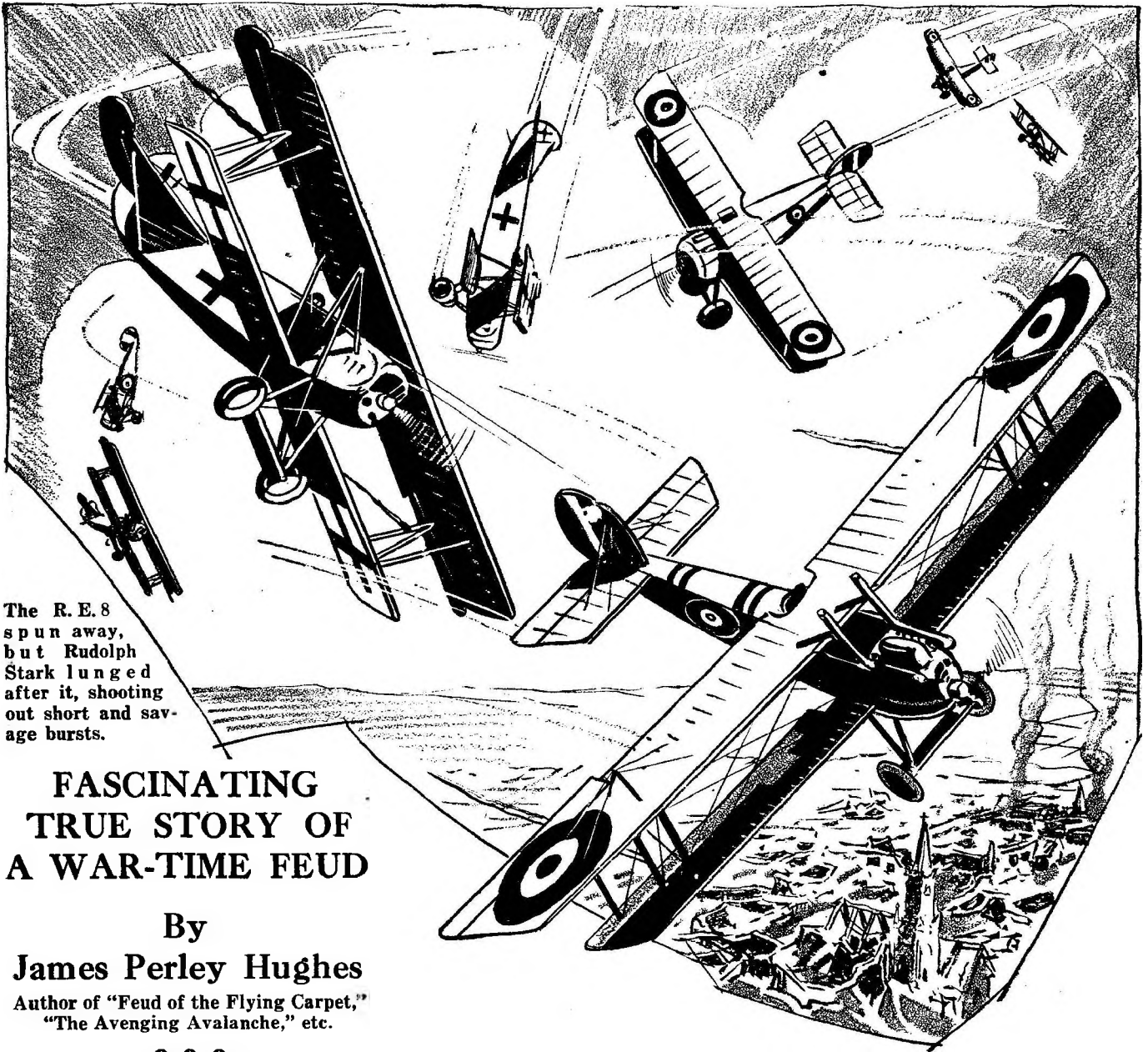
SPEED- 232.8 M.P.H. AT 13,000 FT.
CEILING- 39,360 FEET CARRIES
SHORT-WAVE RADIO. OXYGEN TANK
AND PARACHUTE.



THE FLYING ARSENAL.

W. J. H. H. S.

The Squadron That Would Not Surrender



The R. E. 8 spun away, but Rudolph Stark lunged after it, shooting out short and savage bursts.

FASCINATING TRUE STORY OF A WAR-TIME FEUD

By

James Perley Hughes

Author of "Feud of the Flying Carpet,"
"The Avenging Avalanche," etc.

BRITON and German charged and retreated, dived, zoomed and sideslipped, fighting over the battered town of Arras. Rivals since the early days of the war, they struggled, tooth and claw, yet neither could destroy the other.

Offshoot of the famous Boelcke Squadron, the 35th Jagdeschwader, under the command of Rudolph Stark,

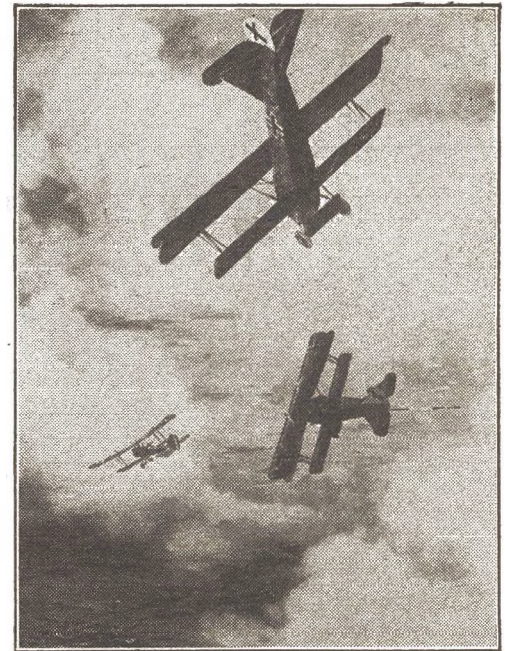
Illustrated by Eugene M. Frandzen

Those two squadrons had fought each other fiercely since almost the beginning of the war. Their two leaders had faced each other in many a fight—and neither had won his bitter feud. Now one of those squadrons was ordered to surrender to the other—ships and men. And from that order came one of the strangest dramas of the entire war.

was engaged with England's veteran squadron, the First, led by Major Philip F. Fullard. Stark had inherited the feud from Mueller, who had crashed in one of the many struggles between these two aggressive units. Captain P. J. Clayson was destined to inherit it from Fullard, but as they swirled over ruined Arras, the pilots looked not to the future, but concen-



Rudolph Stark, leader of the famous German 35th, who led the feud against the British First Squadron throughout the war, was a great artist as well as a great ace. Here we have reproduced for you photographs of two of the paintings which he did of air battles in which he took part. On the left is his conception of a fight in which the Sopwith Camel of Major Fullard of the British First had a prominent place. At the upper right of the same picture is Stark's Fokker D-7. The painting on the right represents the first air battle described in the accompanying article—the battle between the two Fokkers and the R.E.8 over the ruins of Arras.



trated on the immediate present. Death was winging, unseen, among them, and each man labored to kill to keep from being slaughtered.

The combat mounted. Other ships barged into the fray. Rudolph Stark saw a speedy R.E.8 strike at him and turned to engage the swiftly maneuvering Englishman. A signal brought one of his aids to his side, and the two assailed the newcomer. Their Spandaus clattered, shooting out short, savage bursts. The R.E.8 spun and coursed away. Stark lunged after it. Although he did not realize it, Rudolph was pursuing Nemesis, but this he did not know until the war had ended. At that moment, he saw only an accomplished enemy who avoided his cleverest maneuvers.

Stark pulled up as the Briton sped away. His eyes swept the scene. Below was the ruined town of Arras. Cloud banks built massive outlines in the sky, and behind them was the blue dome of heaven. Rudolph Stark forgot he was fighting his most savage foe. Before he left his native Bavaria, the German had been an artist of promise. The majesty of the aerial landscape gripped him. Thoughts of war, of death, and of flaming victims to the jabbering of his guns, were pushed aside.

He snatched out his message pad and made a few swift strokes. Then he returned it to his pocket and kicked his Fokker D-7 around, to enter the battle once more. But the dogfight had broken up, and Stark wing-waggled his men to reform.

"I've got to get this down while it's fresh," he told himself.

He was painting a picture in his mind, forgetting the fleeing R.E.8 in which rode Nemesis. A day would come when Captain P. J. Clayson, who piloted that swift-winged plane, would be Stark's most hated foe, but the artist-aviator did not know it then.

With the Fokkers safely down, Rudolph hurried to his quarters. He kept freshly prepared canvas on his easel and within a few minutes his brush was at work. Planes, maneuvering at mad speed, appeared upon the tightly stretched fabric. Below was the ruined town of Arras. Clouds banked high, and in the foreground were two German planes—his own, flying streamers from the tail, and the sturdy Fokker of his chief aid, dropping down to help him.

Stark worked until the light failed. Morning came, and after the dawn patrol, he resumed his painting. War was a glorious adventure. With his brush he could keep imperishable the scenes he had witnessed. Art

would preserve the glory of German arms. The "blood and iron" disciples in his squadron laughed at his efforts, but Stark knew he was creating something that would live after they and their bellowing machines had disappeared from both air and earth.

With his canvas finished, the artist sought new scenes. His formation was in almost daily battle. Most often its foe was that First Squadron with its boyish major, Philip Fullard.

Stark hated the Englishman. He had tried many times to trap him, but the man's sensational piloting had baffled the Boche. Fullard's calm skill stirred rancor. Rudolph wanted to kill the Briton, yet he admired him. Following a battle in which Stark tried his best to crash his foe, he painted another canvas in which Fullard's Sopwith Camel was the central figure.

The picture, still hanging in Stark's Bavarian home, shows the British ace swinging around, twin streamers attached to the Camel's struts instead of to the tail. Off to the right, the German has painted his own Fokker D-7.

"Now that I have painted him, I am going to kill him," swore the artist.

The feud between the German and British squadrons mounted. Word reached the Boche that Fullard was no longer in the air, and that his place had been taken by Captain P. J. Clayson.

"Then he is the man I'll get," the ace retorted.

He trained his men in mass formation, seeking to discover a method that would insure the destruction of the agile aces the First British squadron had developed. They were flaming swords which flashed across the skies, cutting down any lone German they might encounter, and the Boche leader became frantic.

Captain Clayson was the chief object of Stark's ambitious plans. In addition to being a superlative solo pilot and duellist, he was a leader worthy to succeed Philip F. Fullard.

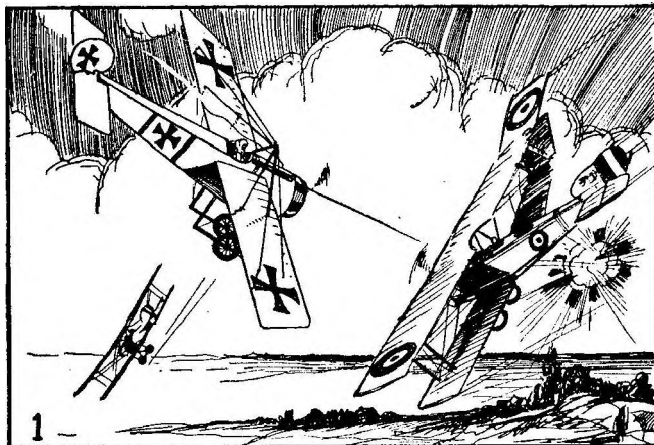
"Get this man Clayson, then Arthur Hazel," Stark told his pilots. "I'll see that the man who crashes either wins promotion and a citation. More than that, I'll paint a picture of the battle in which the victory was won."

The pilots smiled no longer when their commander mentioned his art. He was acquiring fame, not only in the sky, but in the galleries. His canvases were acclaimed. Petitions had been made to withdraw him from the battle line that he might give all his time to

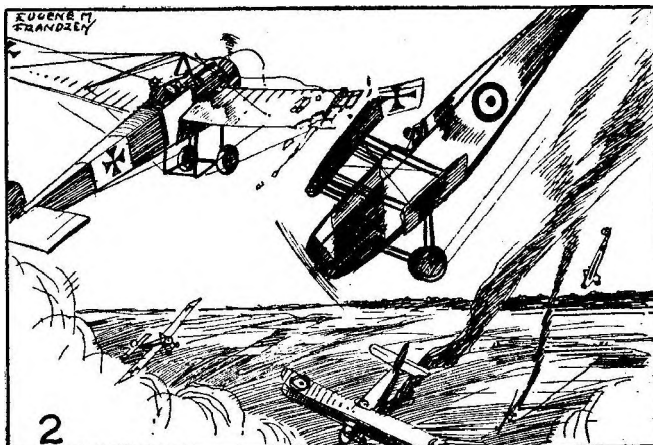
(Continued on page 77)

Lives of the Aces in Pictures

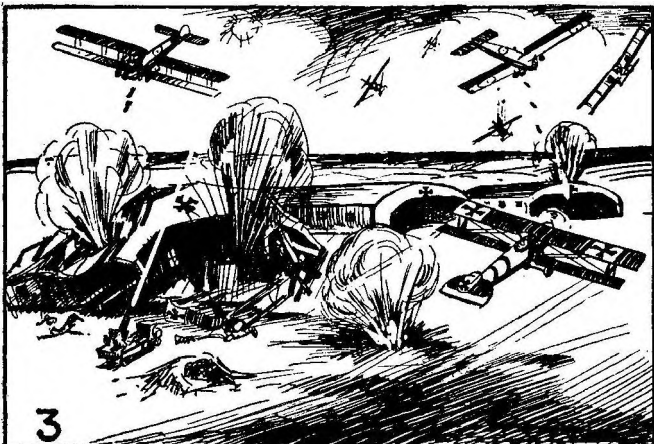
XXXI—Oswald Boelcke, Greatest German Leader



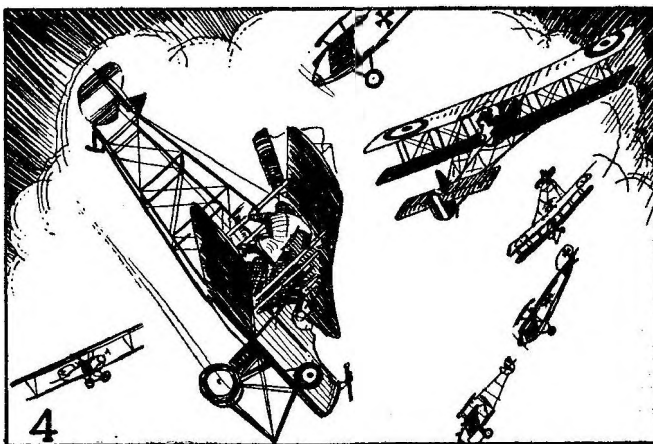
1—Oswald Boelcke, the foremost leader of German *Jagdstaffels*, overhauled the German Air Force in 1916 to prevent almost certain disaster. On one occasion when his *Staffel* met a group of English planes, the leader dived on Boelcke, who ducked and sparred in a battle of maneuvers until he got in a burst that shot the English plane to pieces.



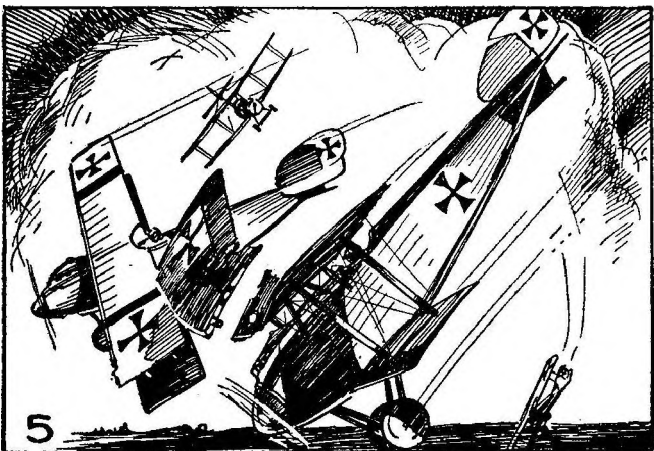
2—In September, Boelcke and his cubs encountered some Martinsydes on patrol. As usual, Boelcke got his victim, while his protegés claimed two others. Then a diving Martinsyde side-swiped one of Boelcke's flyers. The Fokker's right wing crumbled, throwing the ship into a spinning death trap.



3—A big raid was staged over Boelcke's airdrome at Lagincourt. The Allied bombers and their escorts sent an inferno of bombs and shells into the hangars. Boelcke took off, and his cubs followed their beloved leader into the air. Boelcke got an F.E., while the others accounted for several of the enemy and forced them down.



4—Late in October, Boelcke and his men met a squadron of F.E.'s. Boelcke picked on one and shot the plane's controls away with his first burst. As the observer and the pilot fought vainly to right the spinning ship, the observer was pitched into space, and the dead pilot crashed in his plane behind the British lines.



5—On October 28, 1916, Boelcke chased an Englishman. He regarded this man as his 41st victim, but Fate decreed otherwise. One of Boelcke's pupils dived so close to him that the tip of the left wing grazed Boelcke's right wing. The weakened wing fell off, and the nose went down—carrying Boelcke to his death.



6—Oswald Boelcke became an expert flyer early in the war. After his sixteenth victory, the German High Command sent him to the Eastern Front to instruct. Then the demoralization of the German Air Force recalled him to lead the *Jagdstaffel* which later was known by his name through Imperial decree.

The Decoy Duel

Behind That
Simple Mission
Lay the
Unseen Threat—
of Death!

FROM the white fastness of a cirrus cloud-pack rocketed a dun-colored Spad single-seater. With taut wires throbbing, it slanted towards a spot behind the German lines which the pilot had memorized in all its details.

An up-climbing spark curled lazily in front of the Spad's shimmering propeller. It exploded with a vicious crump, filling the sky with smoking metal that snagged through wings and pinged harshly against the plane's engine block. Archie!

The alert eyes of the air pilot, set deep in an intelligent forehead, were wide and unblinking. Responsibility lay heavy upon Joe McCraig this day. He was on his way to a rendezvous he must not fail to keep. Somewhere along the road behind this battery of anti-aircraft guns waited a human being—a man whose name was known only to G-2, American Intelligence. A man without a name, known only by the cryptic number Q-19.

Lieutenant Joseph McCraig had been sent out to make contact with this operator, to receive from him certain documents of the gravest importance, concerning the massing of a great sky armada of enemy ships.

All along the battered Front, Germans were being driven back. American troops were hammering steadily and successfully at lines thought to be impregnable. Gradually they were obtaining mastery of the sky.

But now Germany's air force was gathering itself together in secret for the greatest concentration of war craft the world had ever known. Where was this concentration taking place? When would it strike?

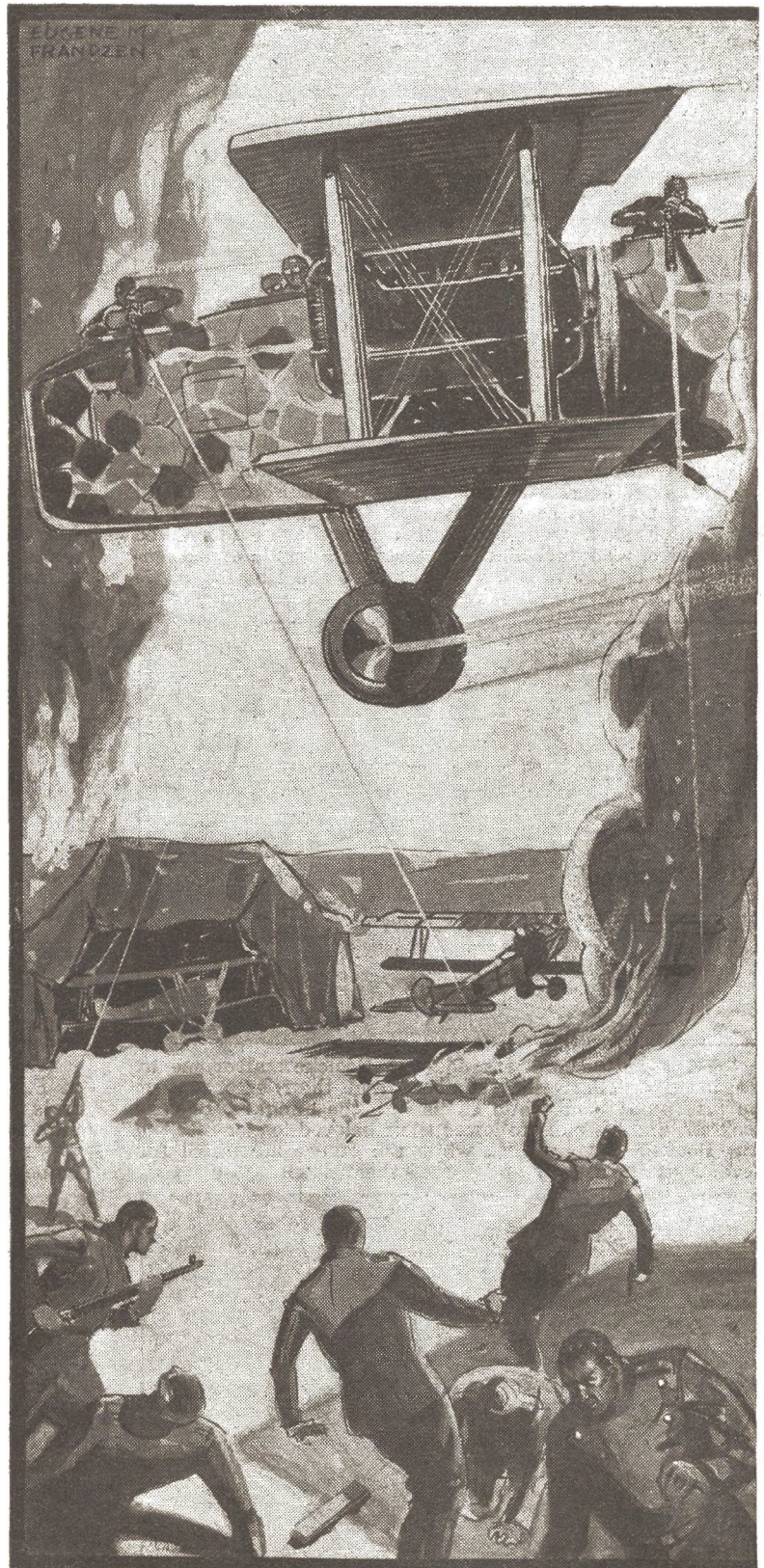
No one knew. It was the task of American Intelligence to find the answers and find them quickly. That was Q-19's job, and McCraig was to bring in that information. There must be no bungling, no mistakes. Joe McCraig must get his plane to the ground, make contact and be off again, all in the space of minutes. He had his orders, and he knew how to obey.

The bursting Archie shells were now far behind him, and he nosed around, easing the stick ahead. Down dropped the Spad with a hissing of taut wires.

After a few minutes he sighted the road in back of the battery. Down this road curved his plane, barely skimming the treetops. There was a cluster of poplars on the north side of the road, close to a monument of loose field stones that formed the

grave of an unknown dead. This was his rendezvous.

He looked at his watch, then hung his head over the pit's edge. Three times he passed over the monument before he saw any signs of life. Suddenly his heart ham-

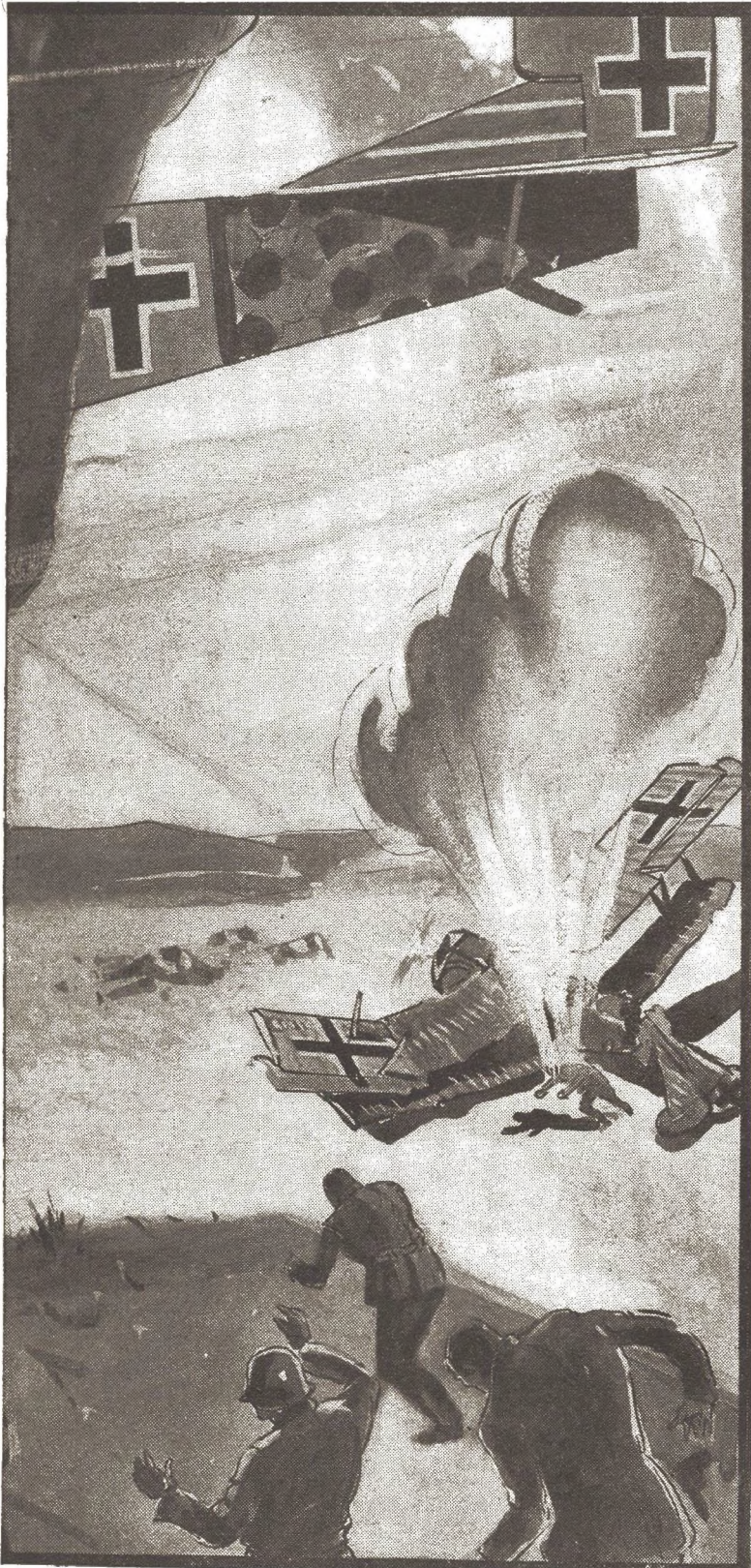


Illustrated by Engene M. Frandzen

GRIPPING SKY NOVELETTE OF WAR SKIES

By Robert H. Leitfred

Author of "Death's Decoy," "Disk of Death," etc.



Back and forth droned the German bomber, slicing the air with its death-chopper, and mowed down that horde of charging Germans.

mered as he saw a sorry-looking human being in cap, smock and wooden *sabots* crawl around the edge of the stone pile and straighten to a standing position.

McCraig waved his arm and pointed towards a level

It was a weird rendezvous to which Garth of G-2 sent Joe McCraig—a rendezvous with a man he had never seen, at a spot marked only by a stone-piled grave. And no one knew that a death trap lay behind that grim tomb—no one except Garth of G-2.

o o o

spot in the field north of the road. A hand waved back at him.

All was going according to schedule. His eyes once more turned to the blue above. Again it was empty. He had two minutes—no more. Then he'd be winging back to the home field, with the precious information beneath his leather coat.

Two minutes.

He started down, and glanced overside as the ship settled. Unconsciously, his eyes swerved to the figure in smock and *sabots*. He saw an upraised face, a waving arm. Then the face was buried in the ground, as if struck by some invisible force.

The airman felt his breath snag somewhere in the back of his throat. His eyes darted over the scene, to a near-by hedge. In front of the hedge he saw an ominous curl of smoke drifting lazily into the afternoon air. He gazed at it thoughtfully.

Was it a trap?

He hauled back on the stick, delaying his landing. In short circles, he spun the plane. McCraig was waiting for the figure in the smock and wooden *sabots* to signal again. But no signal came.

He flew closer to the ground, his forehead creased with thought. Acting on impulse, he shot the wheels of the Spad toward the hedge where he had seen the curl of smoke. A man staggered away, an automatic gripped tightly in his fist.

He turned it loose almost point-blank at the bewildered pilot. McCraig felt the scorching breath of a bullet on his cheek. His arm jerked spasmodically on stick and trigger. The nose of the Spad dipped down, and the Vickers snarled in a short, ugly burst. The man with the automatic fell as if struck with a lightning bolt.

Above the stricken body whined the Spad, smoke whipping back from the barrels of its guns. The plane swerved, banked, hit the ground, fish-tailed around and rolled to a stop. The figure in smock and *sabots* was still on the ground, prone, as Joe called to it.

"Q-19," he called. "Are you all right?"

The figure in the smock moved and struggled erect. The movement dislodged the head-covering, and a tangle of short, dark curls cascaded around a face streaked with grime.

Q-19 was a girl!

Danger was forgotten. The pilot vaulted out of the pit. Almost roughly he grasped both her arms,

and found himself staring into the somber depths of eyes that were strangely sad.

"Arretez, monsieur, please. Your fingers—they hurt."

"Sorry," McCraig apologized. "I wasn't—well, I wasn't expecting to make contact with a girl."

"*S'il vous plaît*—you make the speech so fast. It is hard for me to understand." She replaced her cap and tucked the curls out of sight. "You spick French?"

"No," said Joe.

From beneath the smock the girl removed a small packet wrapped in oiled paper. "My friend Q-19, he have another man give me this. It was for *un Américain air officier*—for you. Now I go."

"Wait. Was there any other message?"

"But no, *monsieur*, only *au plaisir*. Farewell."

The airman nodded and turned towards his ship. Abruptly he swung on his heel and called her back. "Me," he said, "I am Joe McCraig. Maybe I'll be seeing you again?" He was amazed at the urgency in his own voice.

Her dark eyes remained sad. "Why you say thees? You do not mean it. I am a poor peasant—and I am alone. My family they die, from Boche bombardment. Q-19 is my only friend."

"Where do you live, *mademoiselle*?"

"It does not matter, *monsieur*." Her eyes held a hunted look as they swerved towards the hedge.

Joe followed the direction of her glance. "That man tried to kill you, didn't he?"

The girl shuddered. "I do not know. Perhaps."

"You fell down. I thought he had killed you, so I let him have both barrels of my machine guns. He's deader than a week-old corpse."

"So fast you spick."

"Can't help it. You haven't told me your name."

She gave in. "I am Arlene Mignon. Now I must go, for I am afraid . . ." Her words trailed away in a choking gasp. Then her arm was raised as she pointed down the road at an armored lorry rushing toward them. "But look!" she cried. "*Boche! Prenez garde!*" The wooden *sabots* on her feet made a clacking sound as she scurried into the concealment of the long hedge.

McCraig eyed her for a moment, then leaped into the pit. Across the field catapulted the Spad. Into the air it soared, banked and began to spiral upward.

His eyes were on the figure in smock and *sabots*. He saw her run quickly, as if her destination was already fixed. Then she vanished into a cluster of trees.

Below, the lorry had braked to a stop. Blunt muzzles of Maxims behind the driver's seat were pointed upward. Their rattling chatter awoke him to his danger. Bullets thudded into the tail assembly. Snarling, biting slugs of lead raked forward from tail to pit in a vicious burst.

McCraig swore softly and flung the stick over. The Spad fell away on right wings. Its motor coughed, belched out a cloud of black smoke as the cylinders cleared, and jerked the ship from the danger zone. Down dipped the Spad, down and around. Close to the ground it scudded like a frightened rabbit, streaking for home.

He could feel the pressure of that document beneath his tunic. It wasn't fear that was driving him on, but orders. Joe McCraig always obeyed orders. The Archie battery was dead ahead. Cunningly he circled it so as to keep out of the range of the lean snouts of the guns.

The front lines flashed beneath the winging ship.

Bremcourt lay ten miles back of them. It appeared after a few minutes—a brown blur of tarmac and scattered buildings. Nosing into the wing, he halved the throttle and dropped to the field. His mission was ended.

Major Soule glanced up expectantly as the pilot entered. His eyes asked a single question.

Joe nodded and laid the oiled paper packet on his commander's desk. "There it is, sir."

"Any trouble?"

"None to speak of. A Maxim mounted on a truck took a few cracks at me, but I got away without any trouble."

"I don't mind telling you, lieutenant, that I was worried. This particular bit of information means more to Air Headquarters at Souilly than—"

His voice trailed to a stop. The door behind McCraig had opened, and he turned to face the man who was entering. He was a big man in an ill-fitting uniform, with the bars of a captain on his shoulders. McCraig was aware of a huge pink-and-white face, heavy jowls and penetrating eyes.

"Sit down, McCraig," rumbled the newcomer in a curiously soft voice. "I was out on the field when you came in, and from the expression on your face when you climbed from the pit, I gathered you'd been successful in your mission. I'm Captain Garth of G-2."

McCraig acknowledged the Intelligence officer's introduction and sat down beside the squadron commander's desk.

Major Soule pushed the packet wrapped in oiled paper across to Garth. "McCraig came through, Captain Garth. He always does."

Garth smiled appreciation. "Excuse me, gentlemen, while I look this over."

Quickly, deftly, he opened the packet, glanced at the code words, puckered his lips and placed the penciled sheets in his pocket.

"Tell me, McCraig, was there any verbal message passed on to you?"

"None, captain," said the pilot. It occurred to him that he should mention the fact that Q-19 had delivered the document through another's hands—the hands of a girl. But the moment slipped by as the captain began speaking to Major Soule again.

McCraig's mind raced back to the scene behind the enemy front lines. He heard again her voice. "My friend Q-19 he have another man geeve me this. It was for *un Américain air officier*." He could see her now, looking up at him with her sad eyes—a ridiculous figure in cap, smock and clumsy *sabots*.

"I'm a fool," he thought.

Garth shuffled in his chair. "I won't know," he said, "until this message is decoded, just what its contents are, but I am of a firm belief that I'll have the answer to Germany's concentration of aircraft within the next few hours. And it may be possible, Lieutenant McCraig, that I'll need your help again tomorrow."

"I'll be ready, Captain Garth."

"Very well." Garth lumbered to his feet. "I'm getting old," he complained, "and fat. Thanks, Major Soule, for your cooperation."

He pushed out onto the field. A moment later, the roar of a climbing ship was heard; then the sound thinned away into nothingness.

"Just who is that officer?" asked Joe.

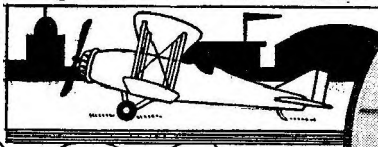
"I don't know, exactly," acknowledged the squadron commander. "He wears the double bars of a captain and packs the authority of a major-general."

(Continued on page 56)



HAPPY LANDINGS

BY ARCH WHITEHOUSE



The Riddle of Richthofen's Death

Did Roy Brown really bring down von Richthofen, or was the famous German ace killed by bullets from the ground? It's an old question, and one that may never be settled. However, here's a new and interesting angle on one of the greatest mysteries of the war. In this department, FLYING ACES gives Arch Whitehouse free reign to express his own personal views on all phases of aviation.

* * *

WHEN a trunk containing military papers, souvenirs and Army equipment was forwarded fifteen years ago from Brisbane to a firm of customs and shipping agents in Sydney, Australia, by Lieutenant George M. Travers, M.C., instructions were sent with it that it should be held until called for. The box was never claimed, and finally the agents had it opened. They found in it, among other things, an actual eye-witness report of Baron von Richthofen's last flight. The account eventually found its way into a well-known Australian publication, and it also brought to light the fact that the man who had written it was not dead, as believed, but was living in another section of Australia. He had forgotten all about the trunk.

After seeing his own report in print, Lieutenant Travers wrote to the Australian publication, enlarging on the original account and giving what is believed to be the only actual eye-witness story of the incident. He explains that this report is an exact duplicate of the one he handed in to his colonel, the C.O. of the 52nd Australian Battalion. If this is so, it is natural for us to ask why this report was never published or discovered before.

However, the facts as Travers saw them seem to go like this.

The Australian and his runner, Private Webber, were doing an observation job from the top of Corbie Hill on the fatal April 21st. He could see in all directions for a distance of about three miles.

"I had no idea a Canadian airman had claimed von Richthofen," Travers states. "All I saw in the air anywhere was Wop May's machine and the red triplane following it. I have since learned that May had pulled out of a fight on the other side of the line, and von Richthofen, who was adept at seeing a flyer leave a fight and sensing the reason, went after him. He had scored most of his victories that way.

"We saw May twisting and darting back and forth to avoid being brought down, and I must say that May was pretty clever. They were coming dead to us along the line of the Somme and straight toward Corbie Hill. May was in a bad position, with the red triplane close behind him. They were within a few hundred yards of us now.

"Just then, a machine gun, ahead and below us, fired

three or four short bursts, and von Richthofen's plane seemed to turn on its side, right itself again, and then swerve sharply to the right and swoop gradually to the ground, landing about half a mile away from us."

We should interrupt here to note that a German observer in a balloon near by made the following report: "Red triplane landed on hill near Corbie. Landed all right. Passenger has not left plane."

But let Lieutenant Travers go on:

"The first three to reach the ship were Captain Cruickshank, Staff Captain of the 11th Brigade, my runner and myself. Cruickshank took charge of things and carried a few papers and a gold watch back to Brigade Headquarters. It was then that we identified von Richthofen by an inscription in the watch. I suppose there is no harm now in stating that I cut away one of his big crosses, a piece of fabric about four feet square. Later on, when I was in England, wounded, I was asked if I would give it to the Australian War Museum and I consented, but I have been there several times since and have never seen it displayed. I wonder if I can get it back."

But there are other angles to this. A Mr. Edward Burrow of Moore, Queensland, a member of Lieutenant Travers' outfit, writes:

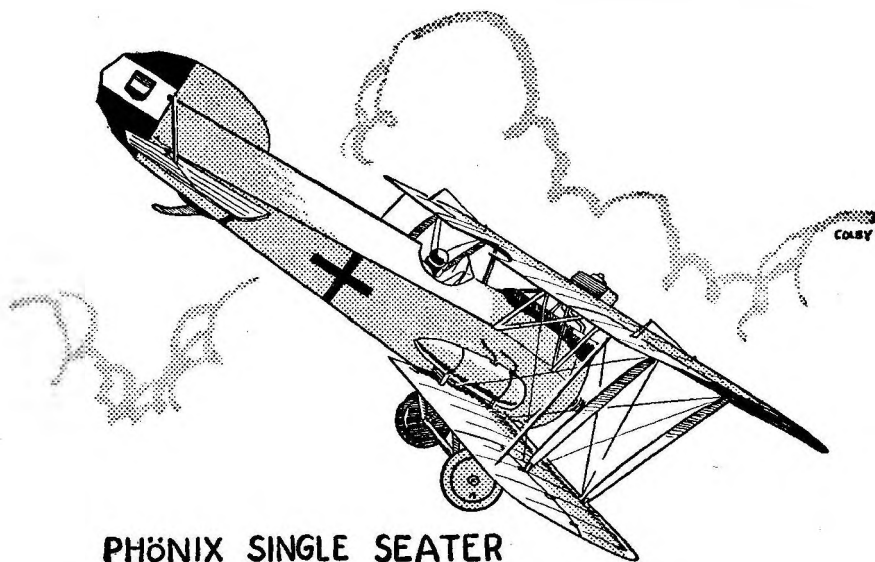
"Lieutenant Travers was an officer of my company, and I can vouch for the correctness of his report as far as the shooting of the German ace is concerned. I, too, went over to the ship and saw that von Richthofen was dead. There was a scramble for souvenirs, and then I saw that the bullet which killed him had entered his lower left jaw and had come out behind his left eye."

Incidentally, a post-mortem examination, said to have been held after von Richthofen's body was brought in to Bertangles—an unusual occurrence—disclosed, according to Floyd Gibbons' story, that a bullet which entered the German ace's *right* side and came out on the left, after passing through his breast, was the single bullet that killed him. It was also stated, according to the same story, that it could not have been fired from the ground.

After seeing the way scout pilots flew on the Western Front, especially in action, we can easily believe that a bullet entering the top of a man's head and coming out

(Continued on page 76)

War Planes Album



PHÖNIX SINGLE SEATER

1918 PHONIX SINGLE-SEATER

THIS machine is a complex arrangement of French and Italian features. Note the tail assembly and fuselage lines. The struts between the wings were splayed outward toward the top, indicating that the upper wing had wider chord than the bottom.

The fuselage was deep and roomy and carried two Spandau guns, light

BRANDENBURG "STAR-STRUTTER"

THIS machine, made under Brandenburg patents and license, was manufactured by the Phönix Aeroplane Works of Vienna. The company was formed during the war by the noted Austrian engineer, Gabriel, who once worked in Berlin with the Albatros Company. His concern also built Albatrosses under license, but they did not get far beyond an experimental stage and are listed as the O-Albatros. The same firm produced the 1918 single-seater, a smart-looking craft, and the two-seater "C" class biplane powered with a 230-h.p. Hiero engine.

The "Star-Strutter" shown in the accompanying illustration was probably one of the most unusual machines produced during the war. It had its biplane wings supported by a queer arrangement of struts set star-shaped; that is, they ran from the various extremities of the wings and met at a central point midway between the two wings. Just what advantage was to be found in this arrangement is hard to state, for it seems like a waste of material for no apparent gain.

The motor in this ship is the 230 Hiero, a six-cylinder job designed by

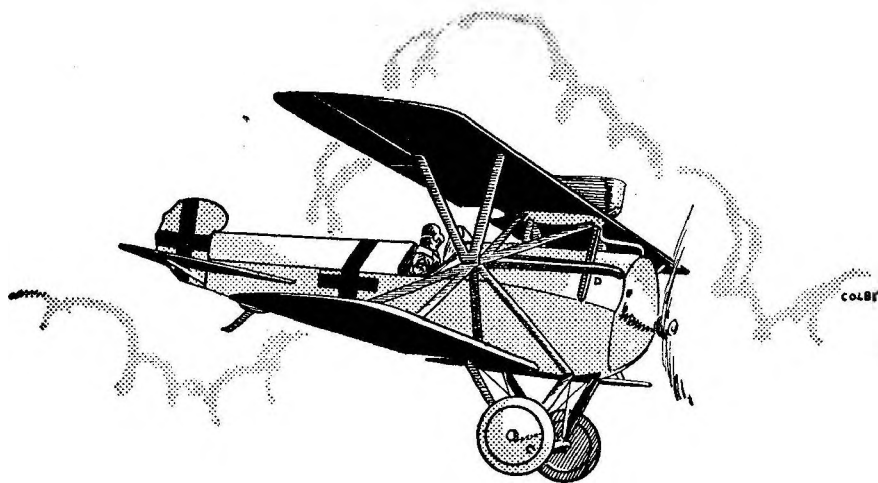
bomb-release equipment and up-to-date instruments. The Hiero 230-h.p. power plant, was used, carrying the radiator in the upper wing and an extra tank on the lower starboard wing.

The center-section was carried on streamlined steel struts. Ailerons were carried on both wings, and the tail plane was mounted between the upper and lower longerons and sup-

ported by a steel stay. The fin was comparatively small, and the rudder displayed the French feathering idea, which gave it interesting lines. The unusual depth of the fuselage toward the tail is interesting.

A close examination of these Austrian ships will disclose the fact that they faced different problems than did the Germans. Their enemies were across the Alps in Italy and they had to build machines capable of flying long distances if they were on the offensive. They had to be capable of attaining great heights if they wished to get anywhere, and above all, they had to have machines that would land in comparatively small areas. Then, to top it all off, pilots flying in this mountainous country had to be able to fly in fog and bad weather—or else stay out of the picture.

We see that most Austrian ships carried extra tankage for long distance work. Then we notice that they have fairly wide wing areas for stability rather than speed. They also go in strong for the swept-back wing, which also gives greater stability in gusty weather.



BRANDENBURG "STAR-STRUTTER"

Hieronimus, a noted Austrian motor-race driver. It was manufactured by the Essler, Warschalowski Co., of Vienna, a firm composed of early pilots who manufactured a ship known as the Autoplan biplane. Little is known of this machine now. In general, the Hiero was moulded on much the same lines as the Mercedes and employed the same radiation system and prop-mounting.

The ship had a top speed of 110

at 5,000 feet and carried two Spandau guns mounted to fire through the prop with a German interrupter gear system. A special tankage arrangement was carried on the upper wing, to care for the long flights necessary over the Austrian Alps to engage the Italians. Just how many of these machines were actually in use is not known, but they did not take the place of the German-built Fokkers and Albatrosses.

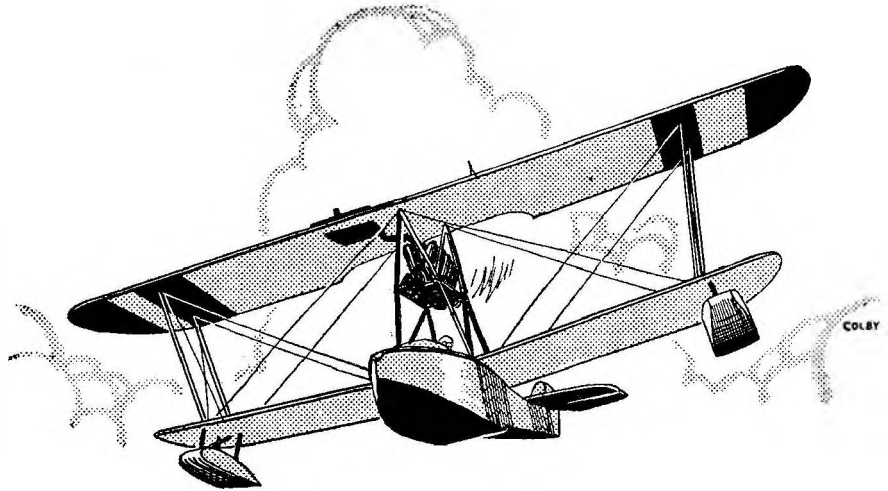
When World War ships are discussed, Austria has never been considered much, and the real story of her part in air battles has never been told. This month we present four of the ships flown by Austrian airmen—the Phönix Single-Seater, the Brandenburg, “Star-Strutter,” the Lohner Flying Boat and the Austrian Argo Seaplane. Not as well known as the Fokkers and Spads—and therefore more interesting.

LOHNER FLYING BOAT

THE Lohner ships were manufactured by the Jacob Lohner Company of Vienna. Before the war, this aircraft and body-building concern manufactured the Arrow biplane, and at the outbreak of war was the only private company in Austria that was manufacturing aircraft. Later, it went into the flying boat business and is said to have turned out some fairly good models.

In 1917, when the war in the air with Italy was reaching its height, Austria was in need of good flying boats. They were using a few German Brandenburg seaplanes, but were unable to get enough, so the Lohner firm put out this biplane model, mounted on a wooden hull. There was nothing startling in the design, but it was neat and well put together. There is a resemblance to several American flying boats of the same era.

The biplane wings were swept back and supported with six streamlined steel struts. The two center struts were set in an inverted Vee, and on these, the 300-h.p. Austro-Daimler engine was mounted. The top speed was 97 miles an hour when the ship was carrying two men and light bomb



LOHNER FLYING BOAT

equipment. The radiator was carried in the top wing, and a small gravity tank was set on the opposite side to even the balance of weight. The motor was set high and in pusher position, and a laminated wooden prop was used as the airscrew. Small floats were mounted out near the outer wing tips. The ailerons were trapezoidal in shape and measured 3.47 m. and were 0.90 m. wide.

The only dimensions available for

model builders come in meters. The span of the upper plane was 9.70 meters. The lower was 7.20 meters. The length was 12.50 meters. The ship carried 400 kilograms of bombs. No detail of the armament is listed in “All the World’s Aircraft” but it is assumed that the planes carried one movable Spandau or Skoda gun. It will be noted, too, that all Austrian ships carried the same markings as the Germans, a Maltese cross.



ARGO

AUSTRIAN ARGO SEAPLANE

HERE’S another new one on you aircraft fans. It’s still one more Austrian ship, and believe us, it was a good one, having been used with

considerable success by the Austrians against the Italians in the bitter days of early 1918.

This Argo ship was, of course, a copy of the German Argo machines,

Next Month »

**Interesting Line-Up of
Armored War Planes
of
England, France and
Germany**

« Next Month!

except that it had a new type of bracing between the wings that proved to be mighty efficient. Its struts were made up of two cross network arrangements that formed a star-shaped truss. The engine was mounted in a steel spider beneath the top center-section. The steel struts were cleverly covered with streamline fairing and made a clean job.

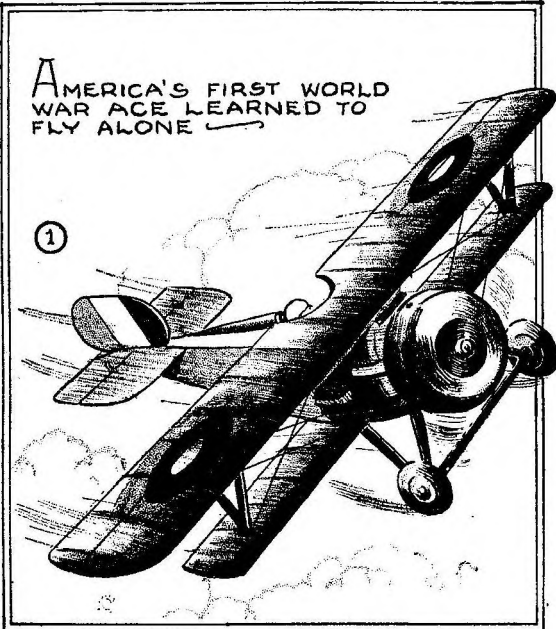
The Argo seaplane was fitted with a Warschalowski 218-horsepower engine which turned out 1,400 revolutions a minute. It had the typical one-step hull and floats on the wing tips. It was a pretty seaworthy craft. Few further details concerning the speed or other particulars of this ship are available.

Here and There in the Air

In this department, FLYING ACES presents some of the odds and ends of aviation—interesting facts about flyers and their foibles, news picked out of the sky here and there. We hope you like it.

PILOTOPICS

By ROY HUMPHRIES

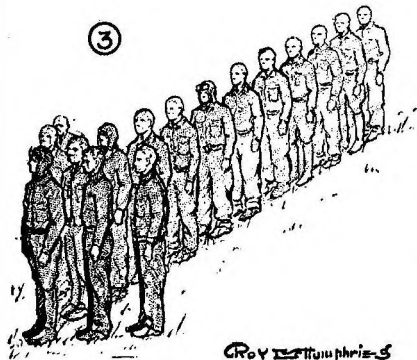


AMERICA'S FIRST WORLD WAR ACE LEARNED TO FLY ALONE

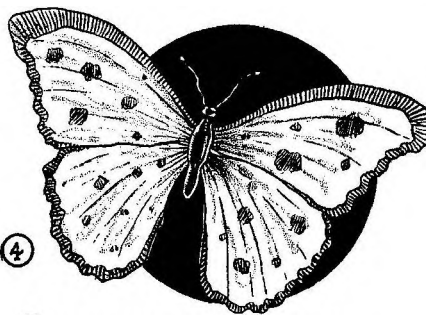


RALPH VOORHIS, PARACHUTE JUMPER HAS FALLEN 250 MILES THROUGH SPACE

HUMAN ARROW POINTED WAY TO LANDING FIELD . . .



ROY HUMPHRIES



BUTTERFLIES HELPED GLIDER TO WIN \$1,000 PRIZE

Stories Back of the Above Pictures

1—Lieutenant Douglas Campbell was the man who learned to fly alone, and it was within six weeks after his first flight across the lines that he became America's first war ace.

2—In his profession of parachute jumping, Ralph Voorhis, of Grantwood, N. J., has made more than 300 "delayed" openings—falling an average of 5,000 feet before opening his chute. It has been estimated that Voorhis has fallen more than 250 miles through space with his parachute still packed on his back.

3—An American flyer *en route* to Vancouver, B. C., who had lost his bearings over the Jericho seaplane base, was aided by grounded fellow aviators when they noticed his predicament. They formed a human arrow pointing toward Vancouver. Forty-five minutes later, the pilot telephoned his thanks from his destination.

4—The conditions of a \$1,000 glider prize required a flight from the top of the Puy-de-Dome in France to the mountain Banne d'Ordanche, across a wide valley at a height of 4,500 feet. Herr Robert Kronfeld, Austria's foremost glider pilot, succeeded in winning this prize after almost grounding until he noticed a flock of butterflies gliding on an upward current. To this fact he credits his success.

FAMOUS FIRSTS

THE first air municipal control board was the San Diego Board of Air Control, which was established on December 19, 1927.

The first complete air squadron of American D.H.4 planes with Liberty motors crossed the German lines on an independent mission on August 7, 1918.

The first airplane catapulted from a dirigible was a two-seater observation plane which was released from the airship *Los Angeles* on May 20, 1930.

24-HOUR CAMERA SERVICE

AN air camera provided with five lenses has been perfected by Army engineers and camera experts of the Army Air Corps after several years of experimentation. It is used in mapping wide areas. At an altitude of 25,000 feet, each camera covers an area of about 350 square miles on a strip something about twenty-five miles wide.

This camera is actually five cameras in one, four being grouped about a central lens in a Maltese cross formation. The resulting photograph is also in a Maltese cross form, brought out in perspective treatment by a "transforming printer." The camera carries sufficient film for 200 exposures, so that in war time, twelve airplanes carrying these could photograph the whole state of Illinois and have printed maps ready for the Army officials in about twenty-four hours.

THE CATERPILLAR CLUB

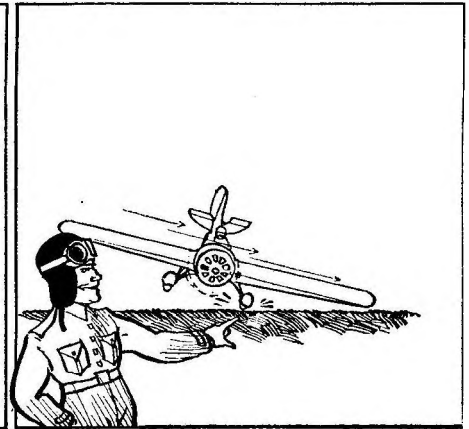
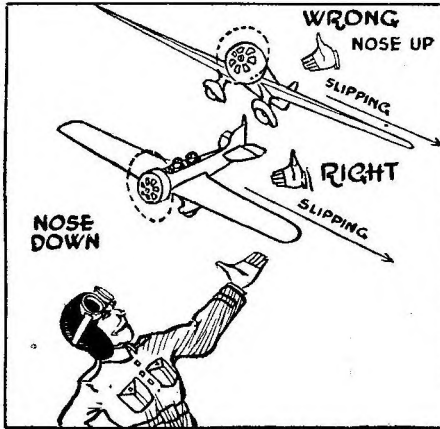
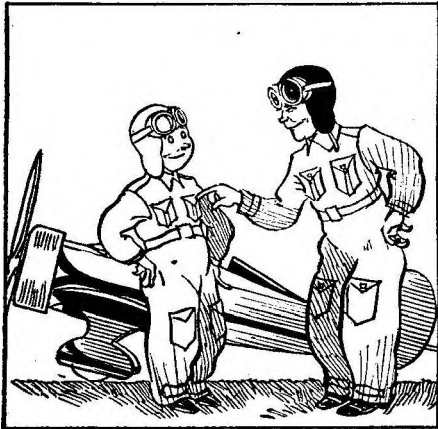
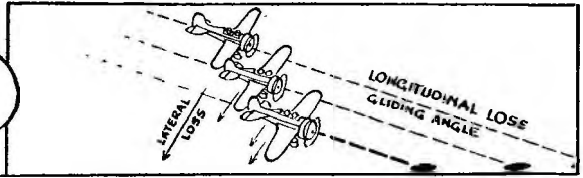
IT was an emergency parachute jump from an airplane in flight by former Lieutenant Harold R. Harris that was mainly responsible for the formation of the mythical organization dubbed the "Caterpillar Club." Lieutenant Harris saved his life through use of his parachute on October 20, 1922, at McCook Field, while flight testing an experimental type airplane. Something went wrong with the controls of his plane, and when it took a dive, Lieutenant Harris thought it time to take French leave and trust to chance with his parachute. What was then considered a miraculous escape from death caused much speculation as to the future value of the parachute in connection with flying operations. Two Dayton newspapermen, in conjunction with several members of the Parachute Branch at McCook Field, got their heads together, foreseeing that there was a possibility of future accidents of this kind and believing that some recognition should be given to airmen saving their lives by means of their parachutes. As a result of their several conferences, the title "Caterpillar Club" began to be noticed in print now and then, and the name of Lieutenant Harris was the first to adorn the roster.

FLYING ACES PICTORIAL FLYING COURSE

ACEMEGOY YOUR INSTRUCTOR. LESSON NO. THIRTEEN



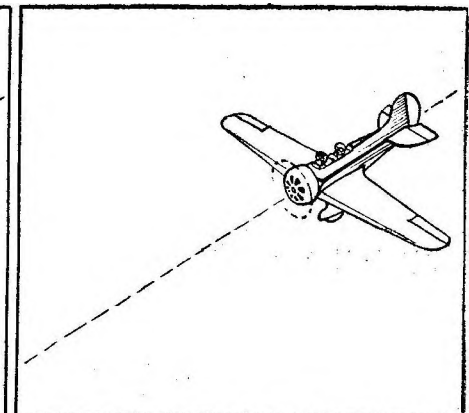
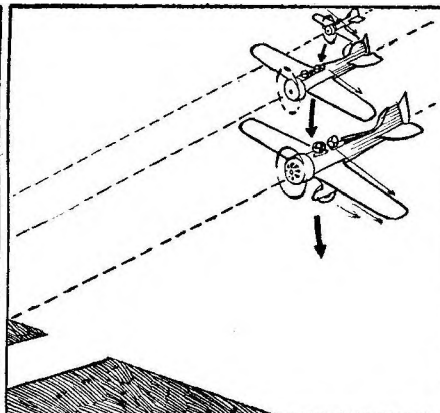
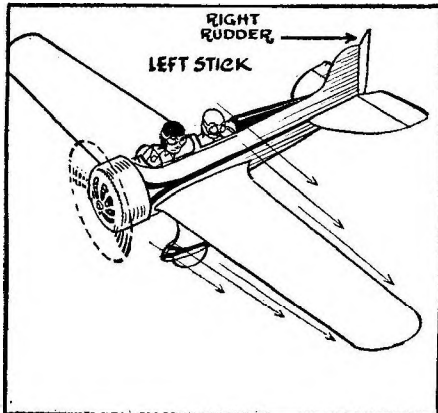
THE PURPOSE OF THE SIDE-SLIP IS TO SHORTEN A GLIDE BY LOSING ALTITUDE ON TWO DIMENSIONS—THEREBY LANDING IN SHORTER SPACE



Sideslipping is about the handiest little stunt in the whole bag o' flyin' tricks. It'll get you out o' some tight places if you know how to do it right—and into some, if you do it wrong.

So before you attempt it, you've gotta savvy it thoroughly. The main thing to keep in mind is to keep the ship's nose about ten degrees below the horizon and your eye on your landing spot, or it'll sure do you dirty.

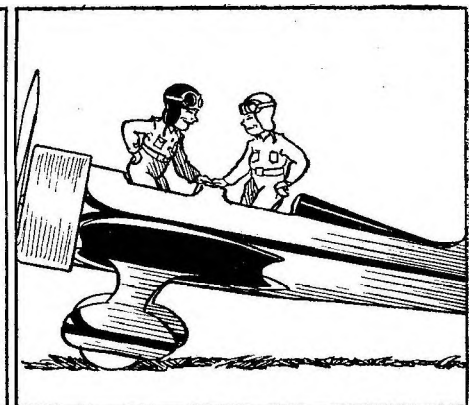
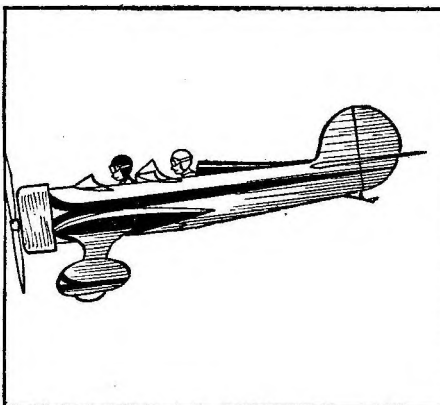
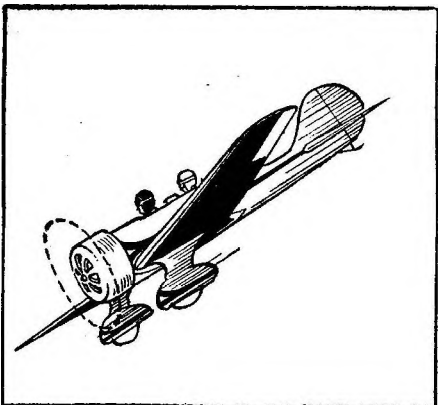
Your wings have gotta be leveled off with the horizon before she hits the ground or you'll wash out your running gear, scuff up a wing tip and do a ground loop like some one who's never been in a ship before.



Now take the controls and give her a little left stick, which throws her left wing down. She starts slippin' off to the left, but she wants to go into a left bank an' turn, which she'll do if you'll let her.

So give her quite a bit of left rudder to keep 'er flyin' straight ahead. Otherwise she'd go into a spiral. OPPOSITE stick and rudder, and she drops off on the low wing-side like nobody's business.

Now we've slipped her off our course to the left. We're out of line with our runway if we land straight ahead, so we've got to slip her back in line with the spot we were headed for at first.



So we give her RIGHT stick and LEFT rudder, still keepin' her nose below the horizon, and slip her off on the right wing until we're back in line with the runway and ready for a straight-in shot.

Now we're gettin' close to the ground, so we've gotta quit slippin' her and level her off so that we won't hook a wing in the ground or wash out a wheel. From here on, you shoot your landing in the same old way as before.

Do all your practicing at high altitude. Don't slip her within thirty feet of the ground, ever, and be sure you have an instructor in with you the first few times you try it. He'll come in handy if you forget.

Next Month—Cross-Wind Landings



WISECRACK-UPS



Taxi in on this runway and pick up a plane load of laughs! In this department, we present a collection of jokes, cartoons, and humorous verse. For all original contributions which we can use here, FLYING ACES will pay \$1. No contributions will be returned unless a stamped, self-addressed envelope is enclosed.



Old lady, to pilot about to take off: Excuse me, but if you see a canary flying around, it's mine. It escaped this morning.

ANOTHER BANK FAILURE

The instructor gave his final command. "Now, remember the maneuver—first you dive, then slip into a bank."

There came a moaning of wires, a splintering of glass and wood. Then the bright voice of the student followed the echoes of the crash.

"Here we are, sir. The First National was the only bank around."

town wonder appeared amid shouts of laughter, Garrity roared out:

"What's wrong with you, Pinkham?"

"Nothing, sir." Phineas eyed the major significantly. "But I think someone used my tunic for a face towel."

ORDER AND DISORDER

During the period the Air Corps was carrying the mail for Uncle Sam, a wag in one of the Zone Headquarters out West found time to issue the following "General Order," of information for the guidance of all personnel concerned:

1. Under no circumstances will a pilot take off unless his motor is running.
2. In case any pilot loses a sack of registered mail during a flight, immediately upon his return to this Headquarters he will fill in Form No. 13, the Request for Sympathy, and forward it to Chief of Chaplains, Washington, D. C.
3. Due to limited facilities for repacking parachutes on this route, under no circumstances will pilots open their parachutes when making forced jumps.
4. Airplanes equipped with retractable landing gear will not be landed or taken off unless wheels are in "down" position.
5. Pilots will not change airplanes while in flight.
6. In case of motor trouble, pilot will immediately contact nearest Zone Headquarters by wireless and request permission to make forced landing. Any pilot making a forced landing without first obtaining permission will be subject to disciplinary action.
7. To assist pilots making blind flights by instruments, a helpful pamphlet has been prepared. It is titled: "Pilots' Prayer Book."

ENTIRELY GROUNDLESS

In the early part of the war, little was known of the great part airplanes were taking.

One British pilot, while on leave, was asked by his companion where he slept. He told her that he slept on a more or less comfortable cot in an almost rainproof hut—and very nearly choked when she asked, in an injured tone:

"Oh, then you do come down to sleep?"

PILE ON, BOYS!

Greenhorn: Boy, that's a dandy pylon over there.

Old-Timer: You said it. You don't run into one of those every day.

ALL BALLED UP

Onlooker: What's the matter with your Moth?

Owner: Aw, somebody put camphor balls in my hangar.

AIRING AN OLD SAW

Whatever goes up, goes up again.

WE'RE TOGGED OUT

Cut: Everybody around the airport seems to be wearing a flying helmet.

Up: Yes, it's the tog of the town.

JUST WALL-EYED

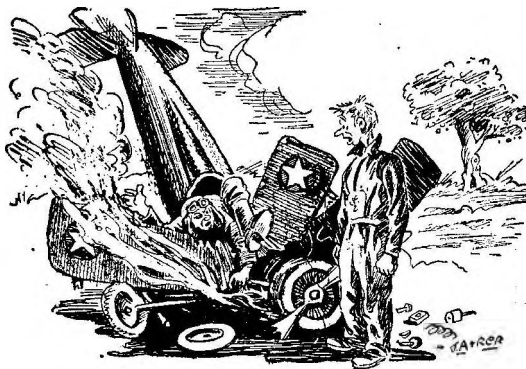
No. One: Why are you standing in front of that mirror with your eyes closed?

No. Two: I want to see how I look when I'm doing blind flying.

RIGHT ABOUT FACE!

One day while Phineas was washing, Major Garrity decided to make him the butt of a joke for a change, and painted a picture of a jack-ass on Pinkham's tunic.

At mess, when the Boone-



"Have a crack-up?"
"No, thanks—I've just had one."

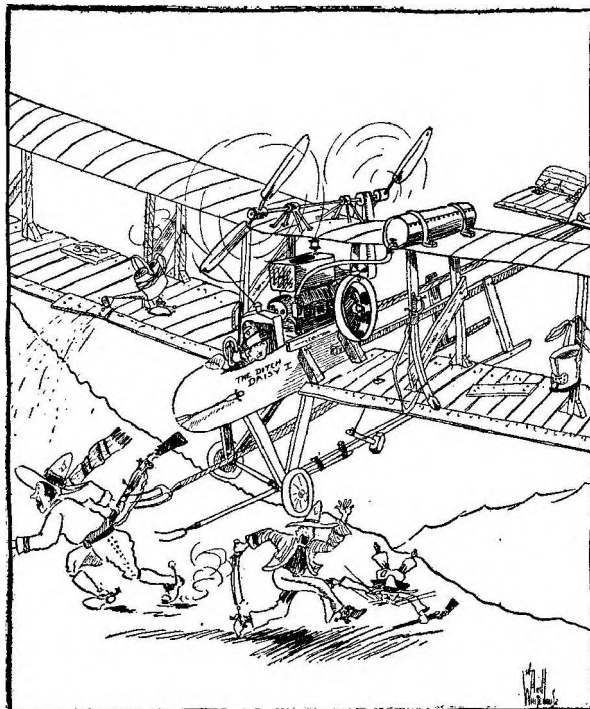
PIKER'S PEEK

Kiwi (to sleepy greaseball): Well, what are you doing?

G.B.: I'm visualizing the airplane of fifty years from now.

Kiwi: How does it look to you?

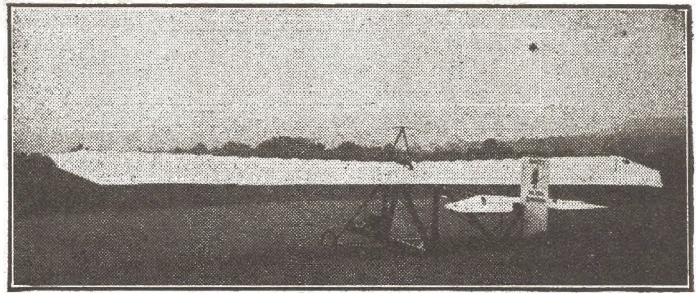
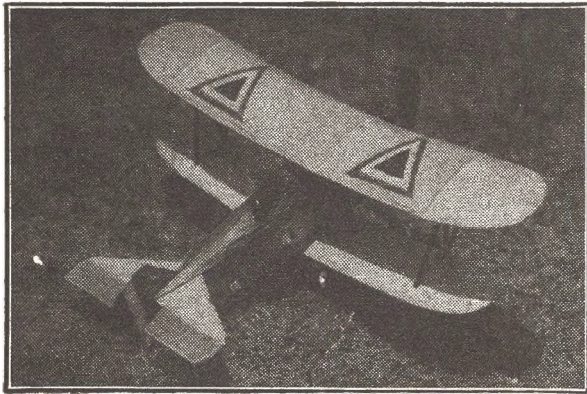
G.B.: Well, it's going so darn fast I can't see it.



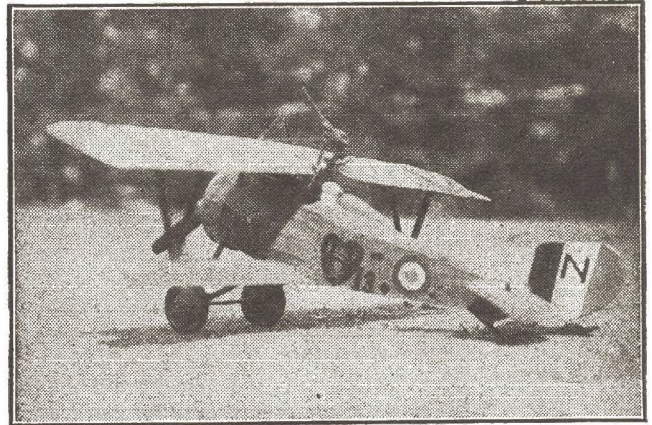
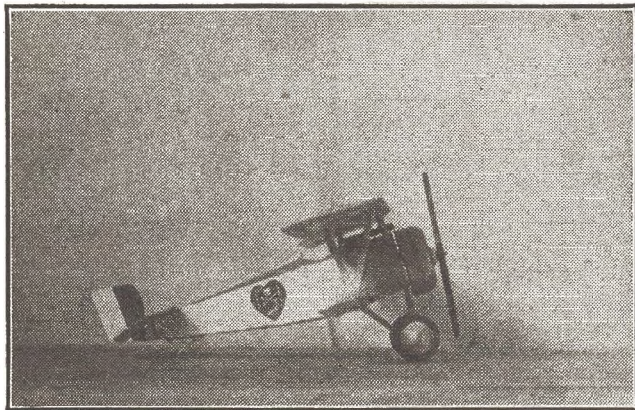
Impractical Aeronautics No. 66—An Early Trench-Strafer

Few people believe that there was air fighting in the Spanish-American War, but if it had not been for our Mad Anthony Mainbearing, San Juan hill would never have been taken, and the Roosevelts can feel as they like about it. In his latest trench-strafing, the "Ditch Daisy," Mad Anthony cleared off the hill in good time for the Rough Riders. This ship was eventually barred by the Hague because of the terrible weapon first brought into modern warfare—the hot-water sprayer, seen mounted on one of the earliest of N-struts. It was with this device that Mad Anthony made things hot for the Spaniards.

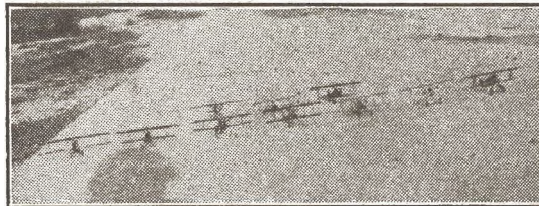
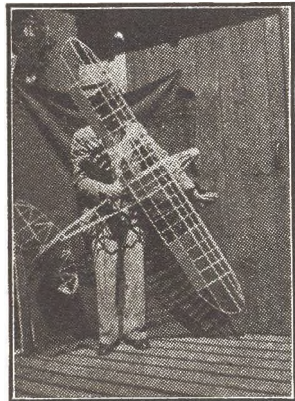
With the Model Builders



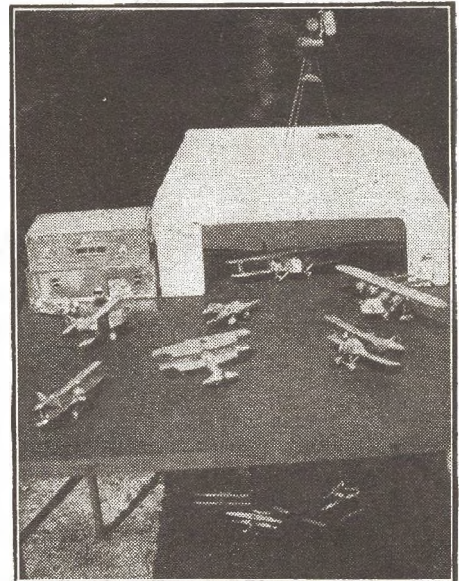
Above: The ship shown above isn't a model, but it's so unusual that we wanted to print the picture on this page. Walter Schaefer, of Clearfield, Pa., built it, and it's a secondary glider called "Eaglet." Cost \$60 and took 4 months to build. Climbs to 150 feet and stays up 2 minutes. Some record, Walter! Left: A Boeing you don't see any more! Here's a replica of the Mexican Boeing 12 built by Richard Eisenbrush, El Paso, Tex. These ships have been replaced.



Here are two splendid models of Nungesser's Nieuport, famous war-time ship, complete with insignia. The one on the left was built by Peter Powers, Los Altos, Cal., the right one by Manfred E. Huffman, Jr., New York City.



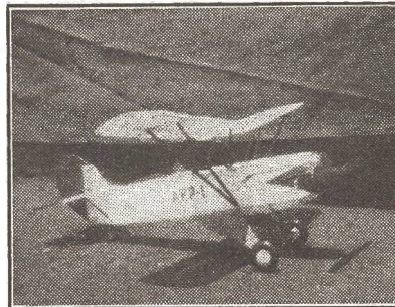
Above: There's a line-up for you! The trim group of models shown above were built by Teddy Heller, Chicago, Ill. Left: All the way from Newfoundland comes the picture of a six-foot monocoque model at the left. Donald Jeans, of St. John's, sent it in to us—and he looks as if he could handle it!



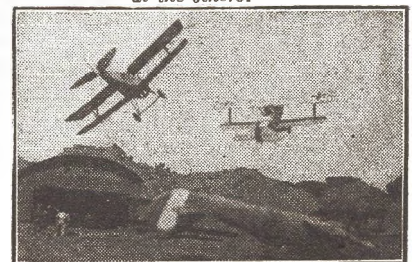
How about this for a complete drome? Major A. Alston Schmutz, F.A.C. leader in Lansdowne, Pa., sent us this picture. See if you can pick out the Sopwith, S.E.5, Sikorsky Amphibian—and guess at the others!



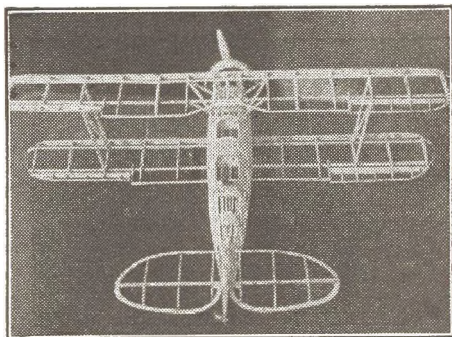
A giant for you! Some one from Corona, L. I., sent us this picture of himself and his 5-foot Bellanca Skyrocket model—and forgot to tell us his name. Recognize him, anybody?



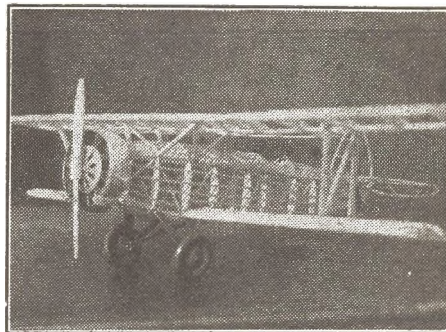
Above: An original design by Roland Pastermack and his brother, of New York City. They say the picture doesn't do it justice, but it looks pretty good to us! Right: There's action in this scene—and a nice crack-up. Here you see a Nieuport C-1 27 chasing a Fokker D-7 away from an Allied airdrome. Anti-aircraft gunners are at the left of the picture. Albert Kofler, Van Nuys, Cal., sent us this interesting picture.



Build the Berliner-Joyce OJ-2



A model of one of the U. S. Navy's fastest observation jobs is yours for the making this month! The Berliner-Joyce OJ-2, one of today's most interesting and famous ships, can be made in three different models from the plans given here. Let's go!



* * *

By Avrum Zier

IN collaboration with the B/J Aircraft Corporation, FLYING ACES this month presents plans to build a replica flying model, as well as a solid model, of one of the Navy's fastest observation jobs. The OJ-2 was primarily built for the Navy, but it is also adapted for Army and commercial service.

The plane is designed to house a 400-h.p. Pratt & Whitney, Jr., or a 550-h.p. Pratt & Whitney, Sr., engine. When powered with the latter, the B/J OJ-2 is capable of attaining a speed of 170 m.p.h. at sea level, and 180 m.p.h. at 11,000 feet (estimated speed).

The complete job is fabric-covered with the exception of the wing panels, which are covered with wood. The wings are of cellulose type and constructed mainly of wood, with duralumin covering the leading edge as far back as the front front beam. Duralumin tubular compression struts and steel wire diagonal bracing compose the drag system. Interplaning struts are streamlined duralumin, while the wires are all streamlined steel.

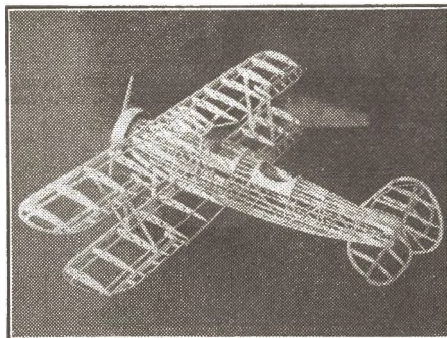
The structure of the fuselage is welded chrome molybdenum steel with duralumin channel fairings. The fuselage is covered with fabric, with the exception of the portion directly behind the motor mount. This part is covered with sheet metal.

To reduce the landing speed by 25%, the B/J Zap flaps have been installed with the Zap aileron. This device is a development of the B/J Aircraft Corporation. To assure a sensitive control over the plane, the Frise-type aileron is used on both upper and lower wings.

The plane is so designed that in time of war the ship can be provided with radio, emergency flotation gear and pyrotechnics. The upper wing stores a .30-calibre Browning gun, fixed in position. In the rear cockpit, a flexible gun of the same calibre and also a Browning are installed. The top fixed gun is provided with five hundred rounds of ammunition and the rear gun with six hundred. Bomb racks are provided under each wing to carry 500 pounds when powered with the junior motor.

Span of top wing	33 ft. 8 in.
Span of lower wing	30 ft. 8 in.
Chord of top and bottom wing	58 in.
Stagger at 1/3 points (in)	30 in.
Length overall	25 ft. 8 in.
Height overall	10 ft. 10 in.

I would like to call your attention to the fact that you can make three different types of this model from the following plans. The three-view layout shown on Sheet 1 can be used to construct a solid model. On the following pages, another three-view layout is shown, twice the size of the one shown on Sheet 1, and half the size of the flying model shown in detail form. By using the three-view shown on the following pages, you can build a model half the size of the large model. The 25-inch model is only shown in detail;



Here's a very clear picture of the framework model of the famous B/J OJ-2, which you can build from the plans and directions presented here. From this picture and the two shown above you will get a good idea of this ship's construction.

that is, only the parts which are necessary for construction are shown full-size. By using the half-scale three-view, you can assemble the large model—and you will have one of the most authentic and beautifully built models I have ever seen.

FUSELAGE

BEFORE attempting to build the flying model, I suggest that you become familiar with the construction shown on the plan. Then obtain strips of 3/32" square balsa. These strips are going to be used in constructing the inner frame of the body. Paste together Sheets 2 and 4. You will have a complete side view of the frame. Using this, lay out the 3/32" strips as shown on plan. Build two sides.

The top view of the frame gives the dimensions of the top cross brace. Cut out all the top braces and glue them

in place. Since you have only one side jig to work with, I suggest that you start cutting out the formers shown on Sheet 6 until the side is ready to be taken off, and the other side ready to construct. You will notice that the stringers do not set all the way into the formers, in order to give the fuselage a more realistic effect after the covering is put on. When you have completed the inner frame, place all the necessary formers on place, top, side, and bottom. Next, glue around the stringers and set the body away to dry. The rear hook is made from rather heavy wire. It is glued in place and thread wound around it to insure its position.

On Sheet 6 are also shown patterns for cockpit covers. Cut them out and glue them in place. After the body is strong enough to be handled, sand the complete structure with very fine sandpaper. Do not cover the body just yet, as more structure will have to be added later. Place the body in some secluded corner so little brother can't reduce it to debris.

WINGS AND TAIL

WE now proceed to the wings and tail. Attach Sheet 3 to Sheet 5, which gives you a full-size layout of the top and bottom wing. Examine the layout of the wings first. The dotted-out line is that of the bottom wing. This outline extends over to Sheet 5. The solid outline is the top wing. Since the left wing is only shown, I suggest, to save time, that you trace over the wings so that you have a left and right of both bottom and top. On Sheet 5 is shown the center section. The left and right wings of the top are attached to this section.

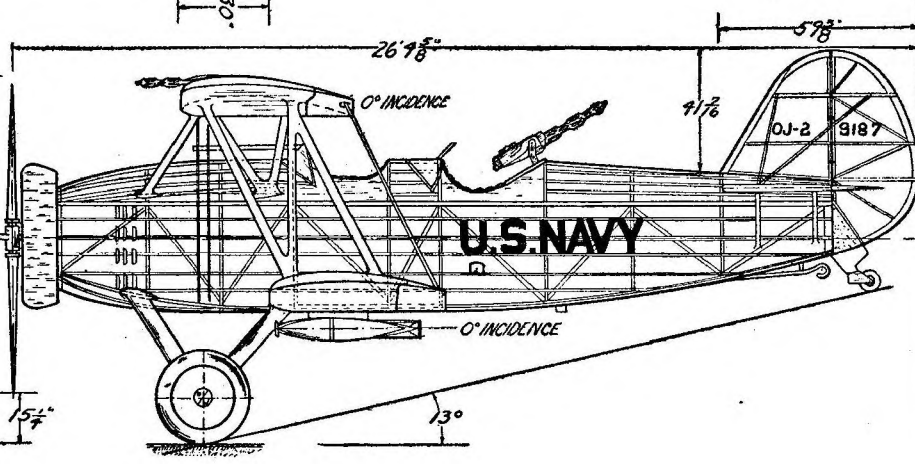
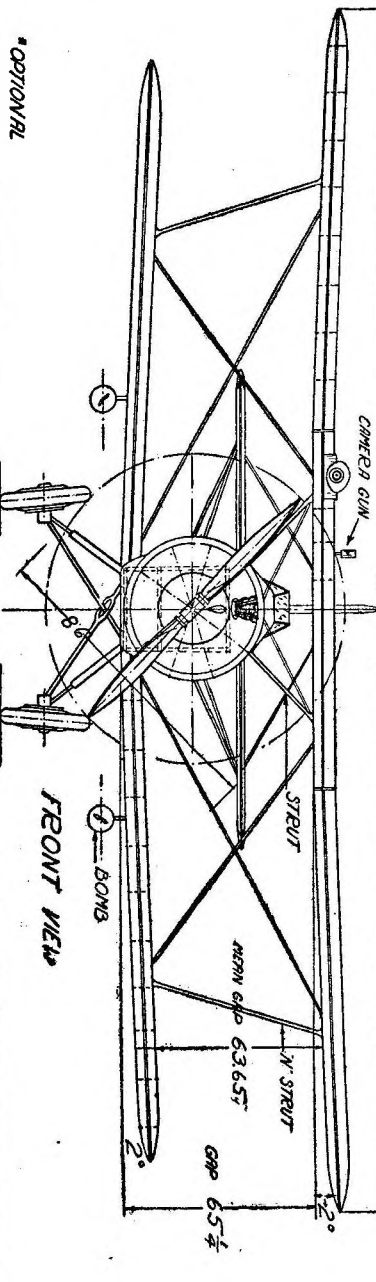
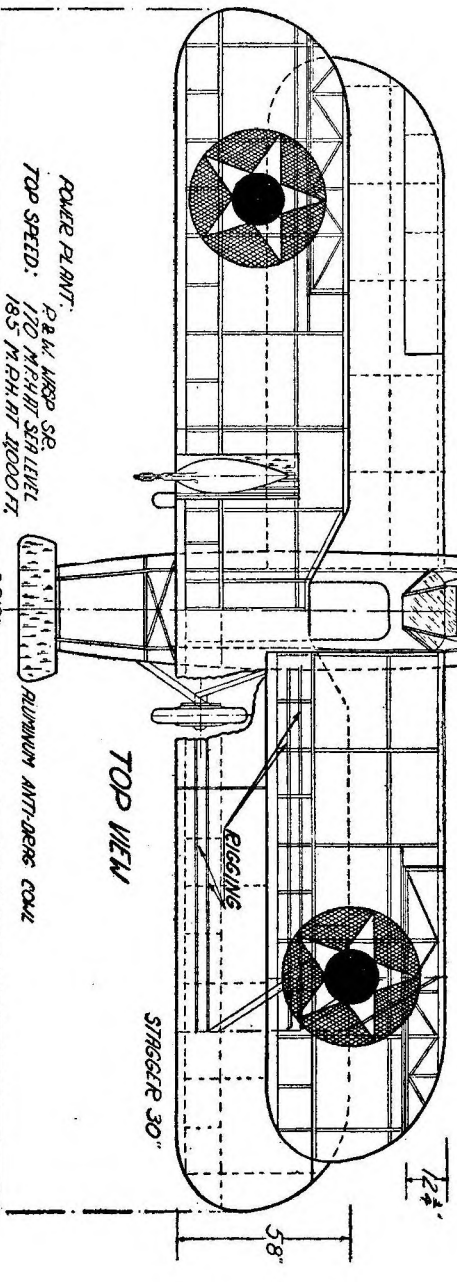
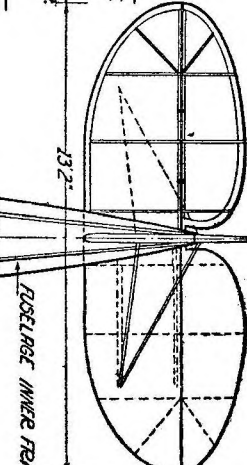
Special attention should be called to the aileron. The aileron is a separate part, and should be built separately. It is attached to the wing by means of tape or metal fittings. Notice that false ribs are also included in the aileron surface.

After you have traced all the surfaces so as to obtain the right and lefts of the top and bottom, proceed to construct the wings as follows: Cut out all the necessary ribs from 1/16" sheet balsa. There are two different ribs. Do not cut the last rib of the top wing,

(Continued on page 80)

CHARACTERISTICS

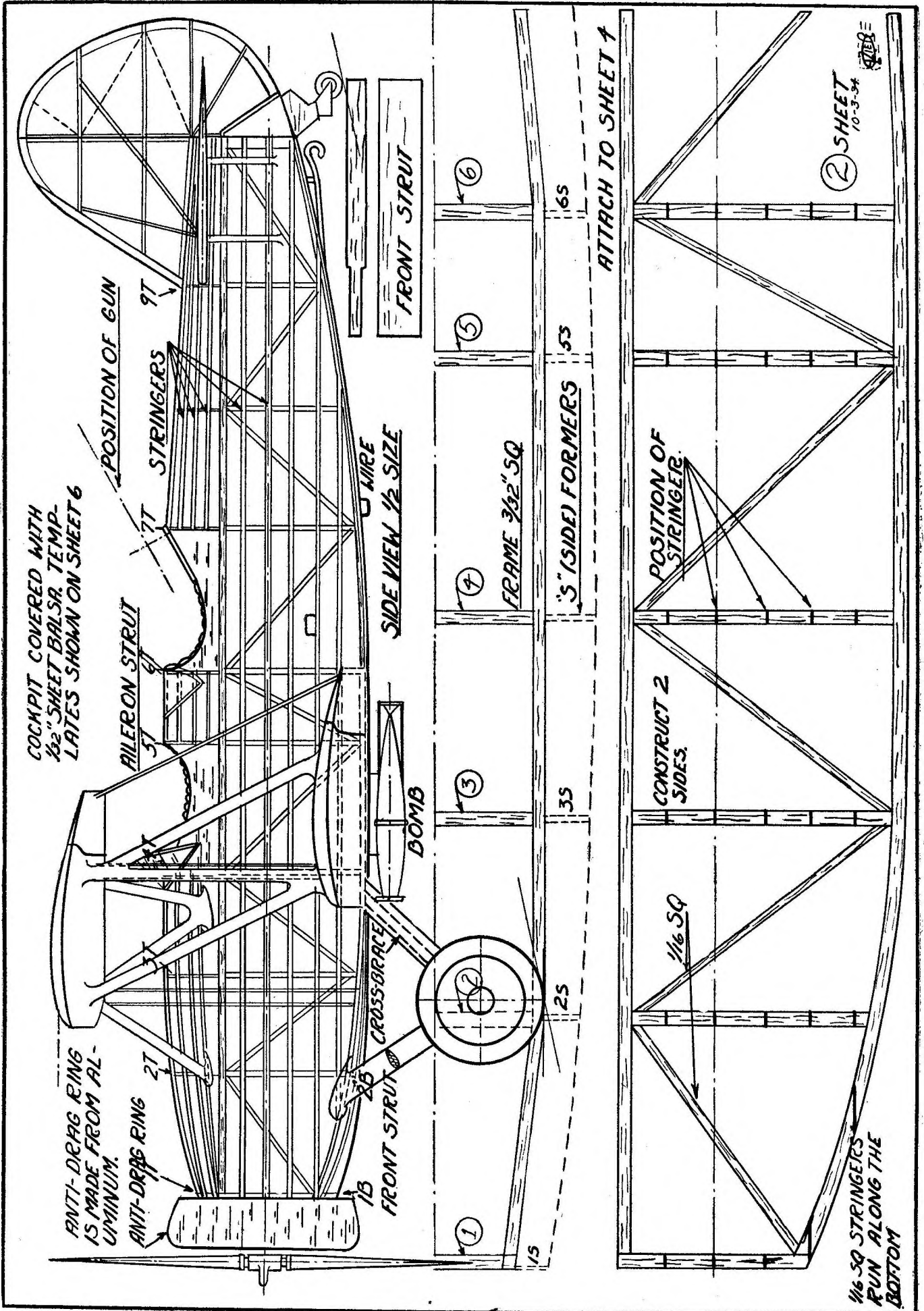
REAR: UPPER LINES INCLUDING AIRLONS	108.2 SQ. FT.
LOWER SECTION	131.0
TOTAL	239.2
REAR: UPPER AIRLONS (2)	13.86 SQ. FT.
LOWER	13.86
TOTAL	27.72
REAR: FIN	182 SQ. FT.
EUDOR	10.64
TOTAL	192.64
REAR: STABILIZER	2.66 SQ. FT.
ELEVATOR	1.46
TOTAL	4.12
WING LOADING (78.59 LB)	1.47
POWER LOADING (14.1 HP)	1.57
FACTOR OF SAFETY	8.5
PIE-FOLD SECTION	0.72

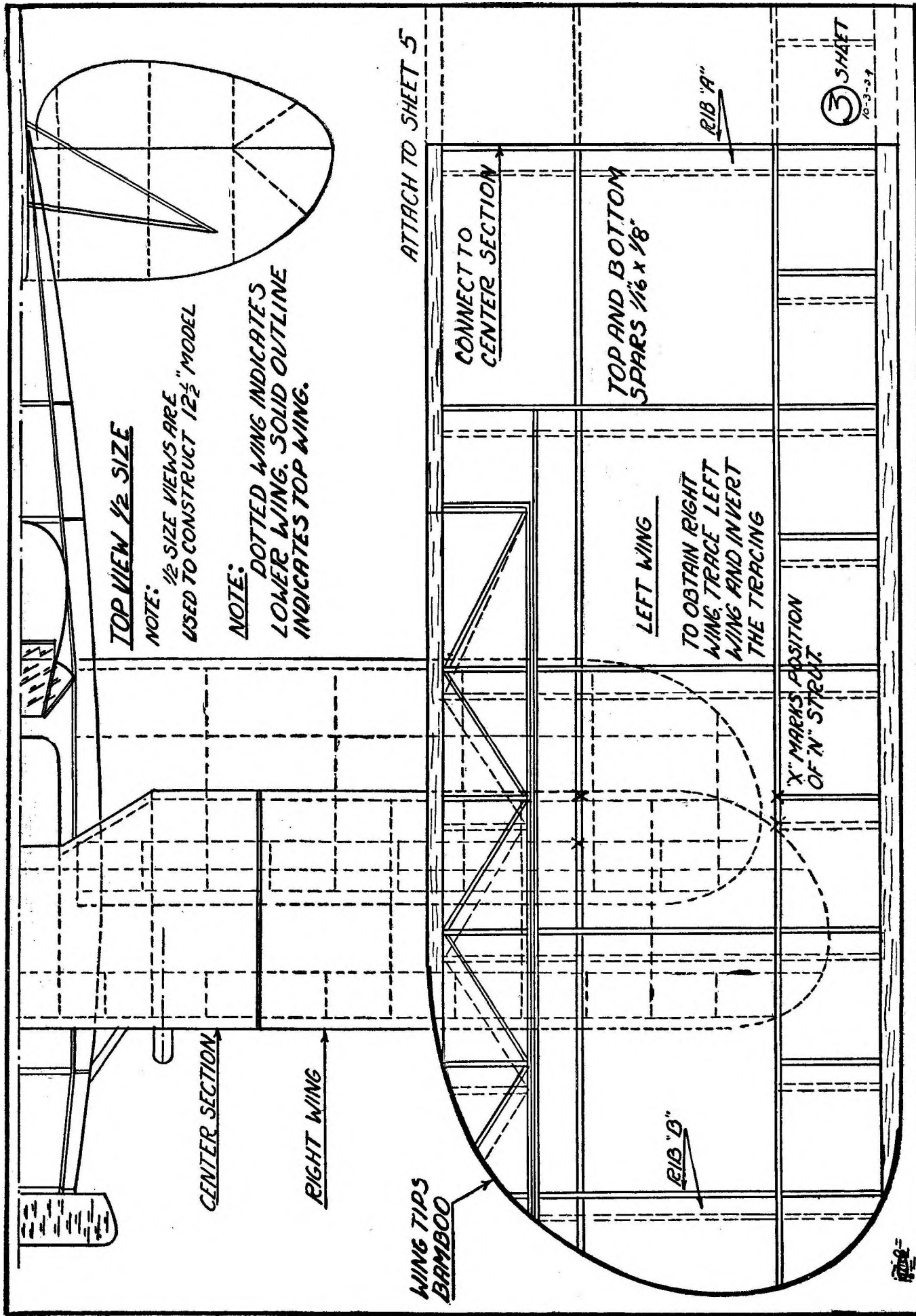


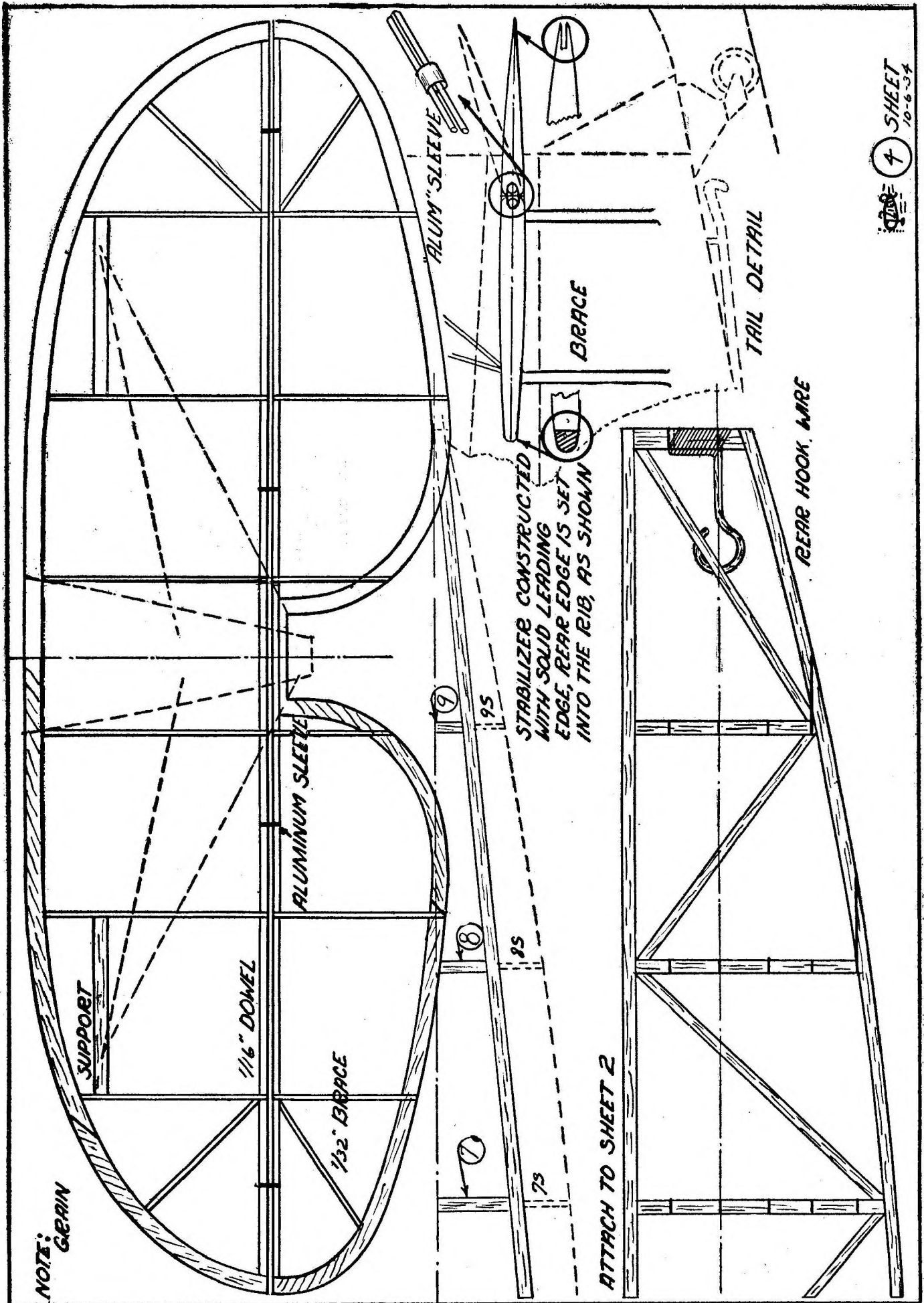
*OPTIONAL

B.J. MODEL OJ-2
 OBSERVATION
 SCALE: 1/4" = 1' 0"
 STRUCTURE APPLIES TO FLYING MODEL
 SCALE OF FLYING MODEL 1/8" = 1' 0"

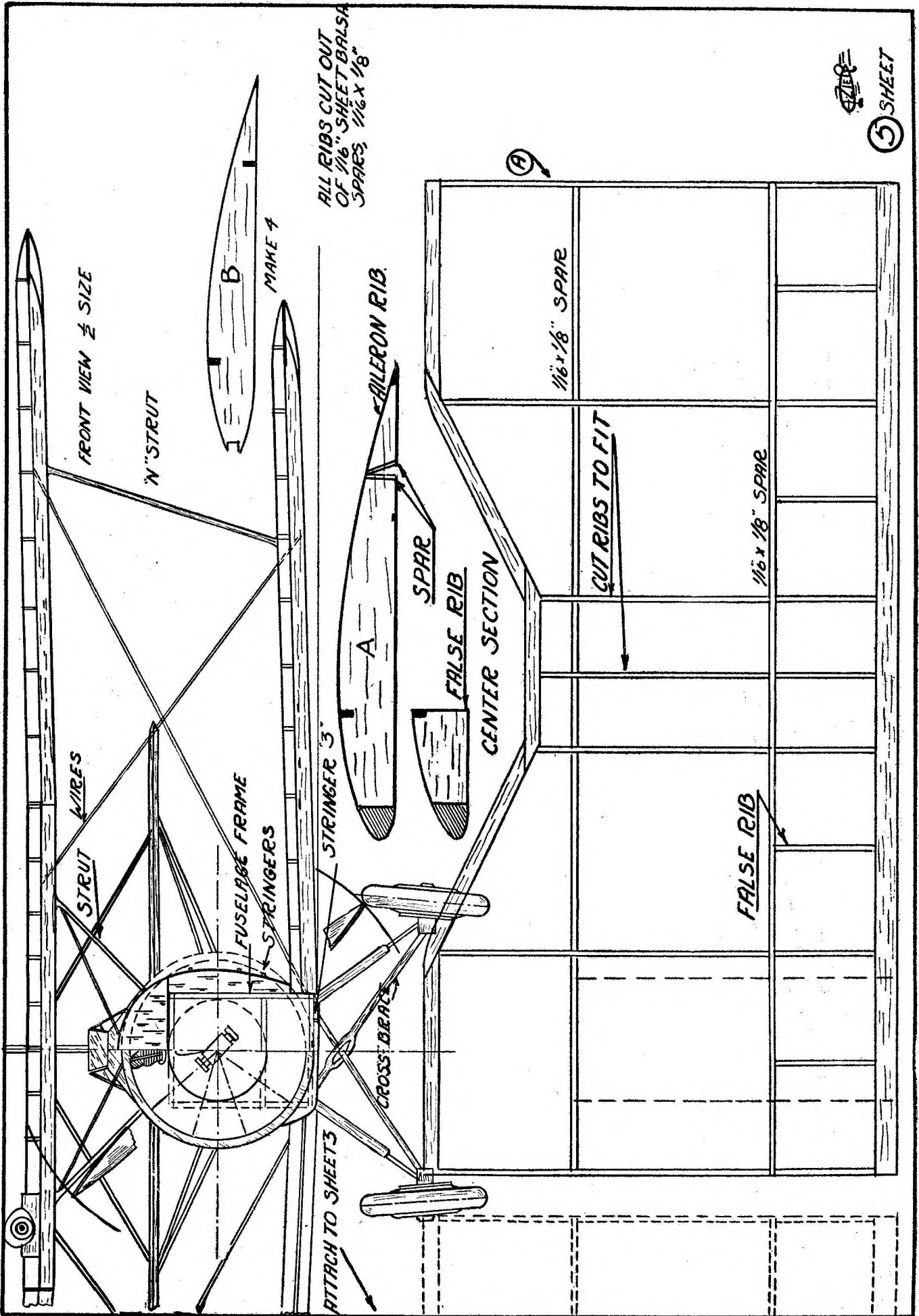
SHEET 1

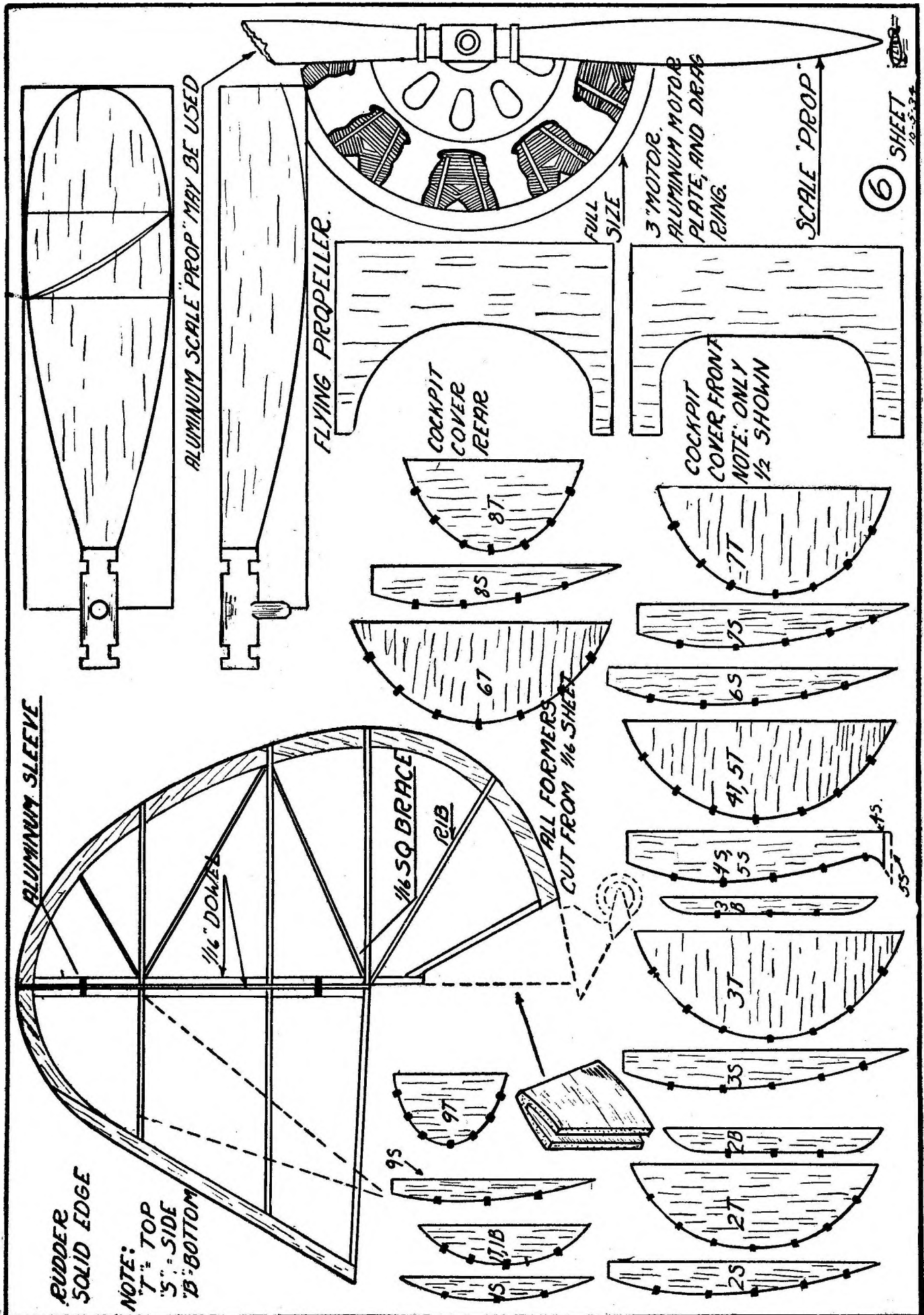




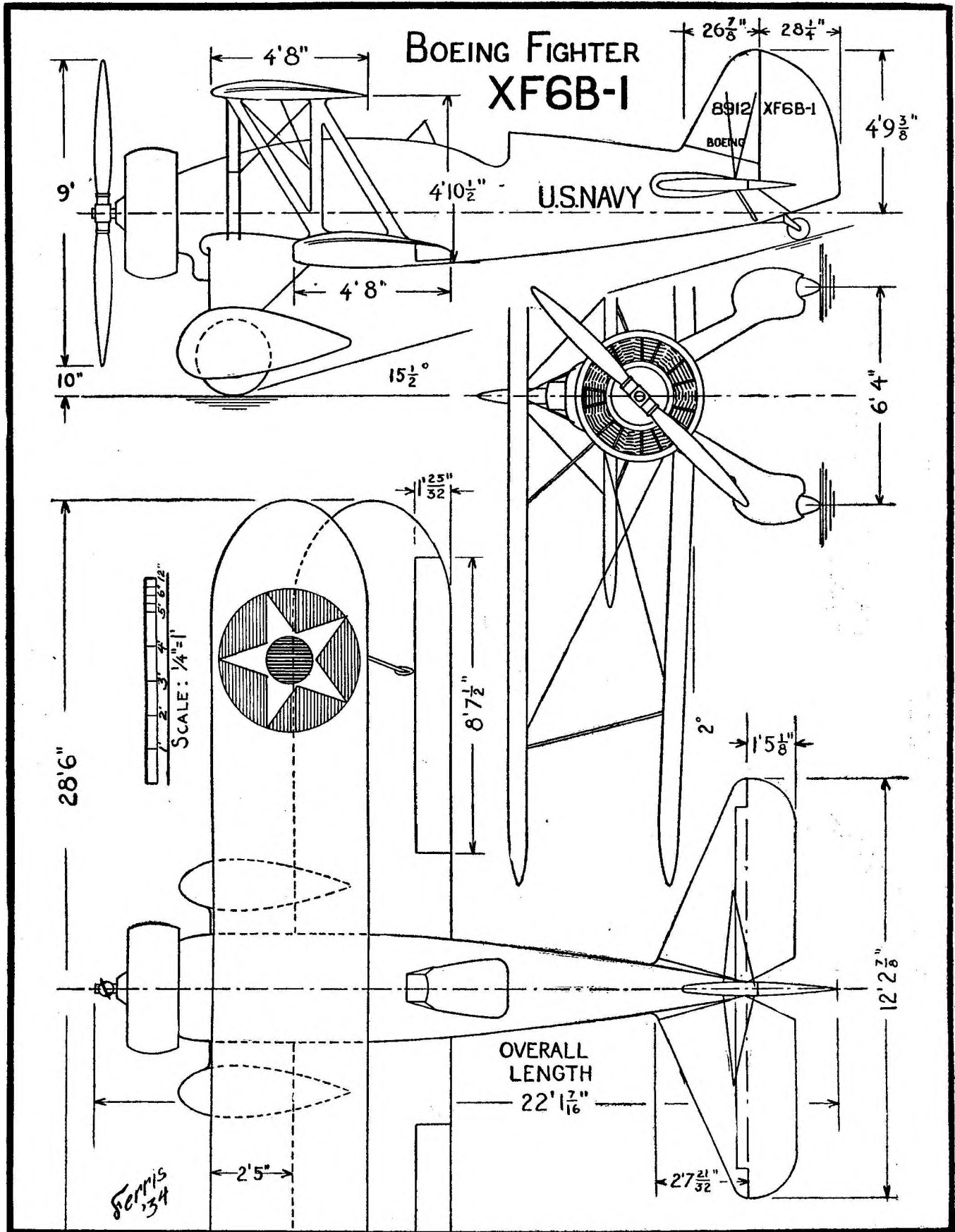


4 SHEET
10-6-34





The Boeing XF6B-1 Navy Fighter



This plane is one of the very latest additions to Uncle Sam's Navy, and because of this, no particulars have been released as yet. However, it is apparently a development of the F4B series, as the construction and lines are much the same. This ship has a Twin Wasp Junior 14-cylinder engine. From the shape of the landing gear, a shock-absorber system is evidently incorporated in the wheel fairings. Making both wings the same size decreases the all-over dimensions, giving better storage ability aboard ship and, perhaps, a little more maneuverability. Navy coloring is silver-doped fabric, gray-painted metal and that shown. Insignia is "U. S. NAVY" under lower wing, and special markings.

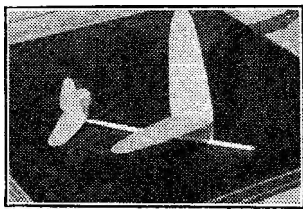
The Flying Aces Outdoor Contest Glider

Here's an outdoor glider that will win contests for you! It's a special FLYING ACES model—and watch it in the air. Extra weight in the nose gives it the power to soar in a breeze.

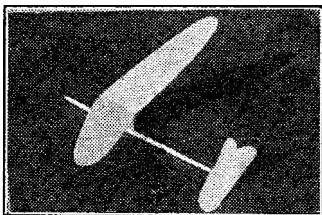
IN the August issue of FLYING ACES, I stressed the fact that a pusher glider has the advantage of not requiring weight in the nose. This may be an advantage indoors, but outdoors it is a decided disadvantage. I found, much to my disappointment, that the added weight a tractor has gives it the necessary momentum to soar in a breeze, whereas a pusher merely flounders around, trying to circle. The type of glider appearing in this issue is of the conventional type. The model is balanced longitudinally by lead. If more weight is needed, modeling clay should be added to the nose.

WING, FUSELAGE AND TAIL

THE wing is made from a piece of 3/16" flat balsa, which is cut to shape and sanded down to the correct airfoil. Three coats of dope should next be applied. Take care to brush it well into the wood. Before applying the last coating, sand the wing and



Two snapshots of the Flying Aces Outdoor Contest Glider, showing clearly the construction of this soaring model.



ner as the wing.

By Julius Unrath

rub it off carefully with a flannel rag so that no dust remains. When you have finished this, the final coating may be applied. This consists of two coats of gloss. The type I used was given me by an auto mechanic who said it was used as a final coating in painting a car. The gloss may best be applied by spraying. When it has thoroughly dried, the wing should be rubbed down with "Simonize Kleener," then "Simonize." A finish as smooth as glass will result.

The fuselage (3/16" x 9/16"), tail surfaces (1/32" flat) and the center-section (3/16" flat) are finished in the same man-

FLYING THE MODEL

AFTER obtaining a flat glide, launch the model outdoors. When launching, hold the model in the right hand, and as near the center of gravity as possible. With the top of the wing facing away from you, launch across your body. This, if done correctly, will cause the model to circle to the right. Flights vary from 30 seconds to many minutes, and the model often passes out of sight if conditions are good.

Please inclose a stamp when asking for information.

From the Model Builder's Workbench

FIGHTING TO A FINISH

IN model airplane building, it seems that most fellows can build models with excellent construction and covering jobs, but can't put a real finish on them. On the flying scale model it is best to use colored tissue, according to the color scheme. After you have your model covered, the first step is to finish the wood parts. There are two ways of making a base for the painting. One is to take ordinary white paste, rub it into the wood, and then sand it. The other, and perhaps more common way, is to use clear dope as a base. Give the wood a coat of clear dope, let it dry, and then sand. Without brushing off the sandings, put on another coat. This time, sand it with very fine sandpaper, making it smooth and even all over. Now give it a final coat of clear dope, using long, smooth strokes. Either of these ways is very satisfactory, as each fills up and closes the pores, giving a proper base for painting.

Now comes the coloring or painting of the model. Any of the good enamel dopes now on the market are very reasonable and suitable for the work. Acetone plays an important part in

painting work. It is used in large quantities; therefore it is advisable to have plenty on hand. Pour off some dope—the color you are using—into another bottle or beaker, and add the same amount of acetone, making the mixture half and half. Shake the solution well, and then with a fair-sized camel's hair brush, set to work on the wood parts. Put enough coats on the wood to give it the same color value as the paper. Let this dry thoroughly.

In the meantime, add more dope to the mixture, making it about three-quarters to a quarter in consistency. Mix this well. Now paint the entire model, wood parts and paper coverings. This will require from three to eight coats. Three or four coats are needed if the model is wanted for flying purposes, and about seven or eight coats if it is used as a display model. Allow this to dry over night so that it gets a good cement surface or crust. With the fine brush, put on all trimmings—stripes, insignia, numbers, etc. Then put on one coat of clear banana oil. This acts as a base for polishing.

With a small amount of any polishing material, such as floor wax, simon-

izer or furniture polish, on a soft rag, polish the entire model well. The same method is used for all parts, such as struts, wheels, prop, etc. The finished model will shine like a mirror and be well worth the extra work. Go to it, and you will be well satisfied with the results.

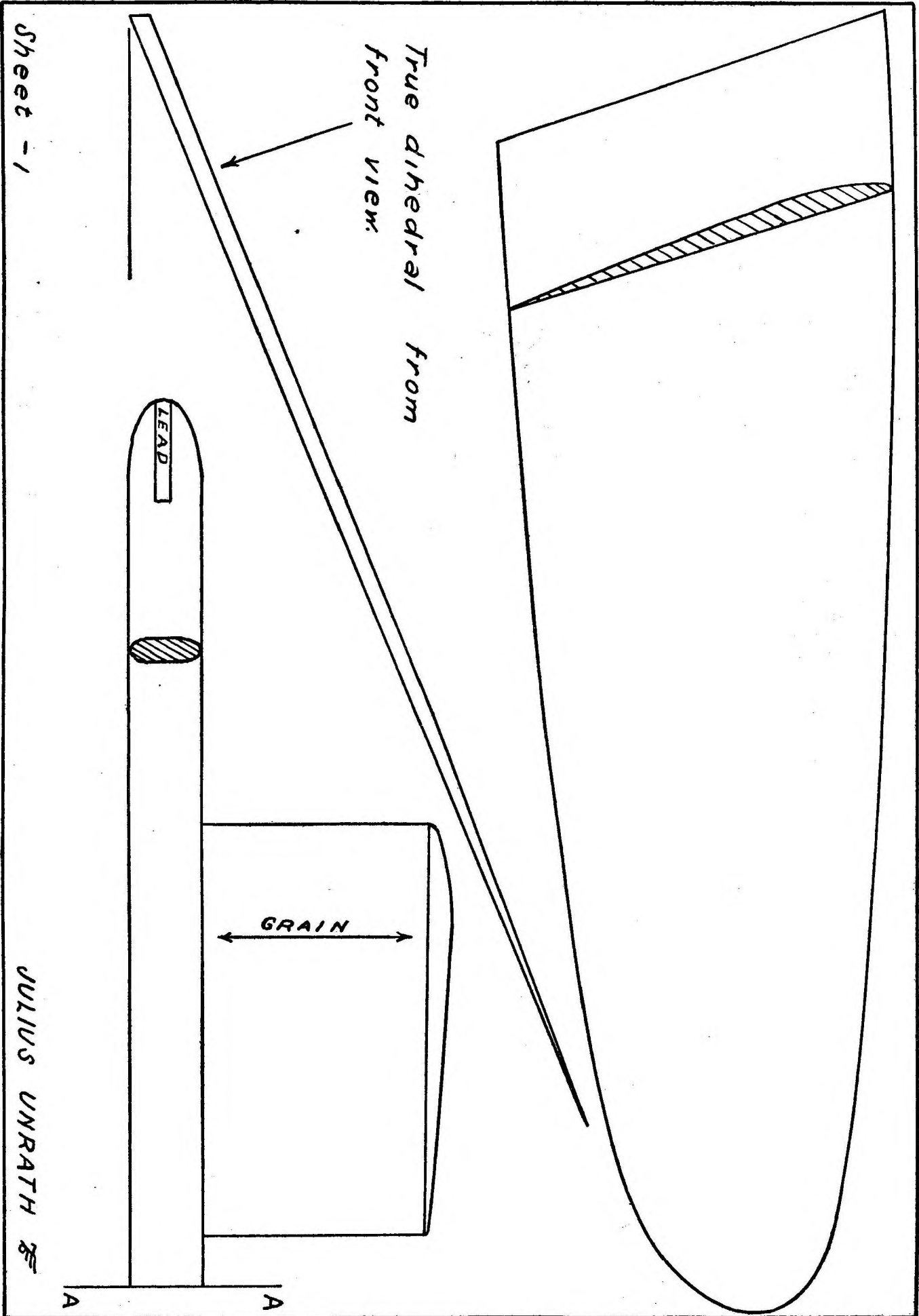
GILBERT DEVORE.

BUGABOOS FOR BUILDERS

ONE bugaboo of model builders is the spreader bar in the landing gear of small solid models. Sometimes the spreader bar given in the plan is not large enough to take an axle. In this case, make a bamboo or balsa spreader bar of the thickness called for, but whittle it down at the ends. Simply combine the axle and spreader bar. The wheels will slide easily and revolve freely on the thinner ends. A drop of airplane cement on the ends of the bar will prevent the wheels from slipping off.

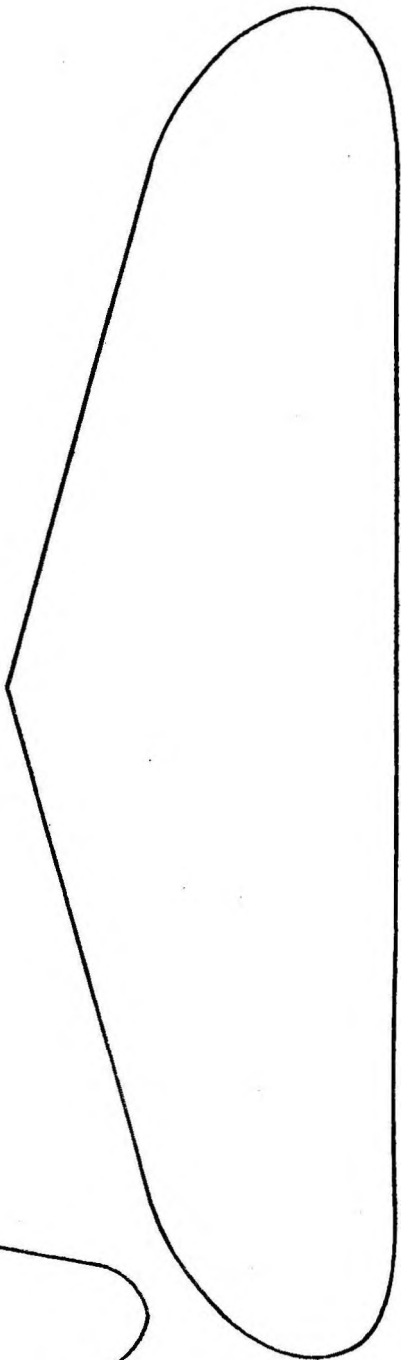
Feather quills of different sizes can be used for landing gears, struts, and skids for solid scale models. Small feather quills cut to the proper size make effective exhaust stacks.

BILL WELLINGTON.



Sheet - 1

JULIUS UNRATH



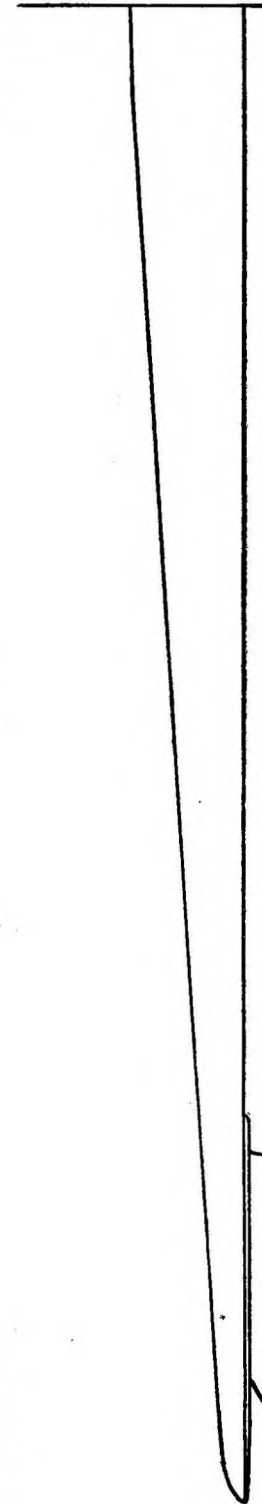
To obtain a smooth fillet give all joints 5 coats of cement.

~ TO BALANCE MODEL ~

Longitudinally - use modelling clay.
Laterally - give light wing coat of dope.

Leading and trailing edges of tail sur - faces should be rounded.

A



Sheet - 2

JULIUS UNRATH

Citation and Awards of the Flying Aces Club

The Distinguished Service Medal of the Flying Aces Club has been awarded to the following members of G-2 for exceptional services to the club:

- | | |
|-------------------|-------------------|
| Gordon Irwin | Peter Lusenskias |
| Bob Tartaglione | Gerald Higgs |
| Edward Penfield | Raymond Barth |
| Bob Dieckmann | Melville Marks |
| Kenneth Rubin | Roberta Goldberg |
| Alvin Blake | John Gilchrist |
| John Stokes | John Banich |
| Herbert Klemann | Joseph O'Keefe |
| Leonard Czaplicke | David Score |
| Christian Berger | John Hettenhouser |
| Elfy Jonilionis | Daniel Sullivan |
| Walter Kaufman | Edwin P. Elder |
| Billy Taugust | Jack Raye |
| Edward Sandgren | Lewis Cameron |
| Dickie Grossberg | Edward Stark |

The following winners of the Distinguished Service Medal of the Flying Aces Club have been given the award of the bronze props for additional services to the club:

- | | |
|-------------------|---------------------|
| George Bertalozzi | Jack Brown |
| Leo Lariviere | Edgar Drake |
| Alfred Szulinski | Jack Benson |
| Paul R. Guerrero | R. A. Blocki |
| Howard Mottern | Albert W. Kirschner |
| George Kopta | George H. Schultz |
| Helen Greene | Robert G. White |
| Lutz Flynn | Francis Lafferty |
| Frank Ridder | Paul J. Podany |
| Charles Kandigian | Anthony Konsevage |
| Charles W. Treen | Bradley G. Kohn |
| Charles Hoelle | Charles Ames |
| W. L. Stewart | Harold Smith |
| Ward Lanitot | Walter G. Anner |
| William Patterson | Willard Lidgard |
| Walter Smith | Walter W. Schrieber |
| Harrison Brennan | Gordon Morton |
| Robert W. Schefke | Thomas Sheldon |
| Cosimir Trawinski | Francis Schweitzer |

The following members of G-2 have been cited by the Flying Aces Club for exceptional services to the club and are being considered for the Distinguished Service Medal:

- | | |
|--------------------|--------------------|
| Gene Jordan | Russell Griffith |
| John Rankin | Sol Edwards |
| Wayne Grant | Bill Cooper |
| Harold Nightlinger | Jack Kendall |
| Jack W. Staff | Dinny Waterman |
| Bernard Glassman | Billy Cassidy |
| Stanley Piendziack | Joseph Von Waldron |
| Donald Jodoin | Buster French |
| Paul McCoskrey | Robert Hatcher |
| Phillip Brown | Warren Huffman |
| W. G. Blocki | Stanley Rudee |
| Paul W. Landrock | William Wethevald |
| Abraham Malin | Forrest Wilson |
| Ronald Smith | Robert Sadoff |
| Richard Dodd | Robert Hunt |
| Roscoe D. Judd | William Horn |

JOIN THE FLYING ACES CLUB

No Dues! Easy to Join! Organize Your Own Squadron!

To advance the cause of aviation, over 35,000 men and women, boys and girls, I have banded together to form the Flying Aces Club. It's easy to become a regular member. Fill in and mail the application coupon at the bottom of this page with a stamped, self-addressed envelope for the return of your Official Membership Card in the largest aviation club in the world.

It costs nothing, no dues. After becoming a member, you will be all set to win your Cadet Wings, Pilot Wings, Ace's Star and, perhaps, the Distinguished Service Medal. Take the first step now. Fill out and mail the Membership Application Coupon.

You will find it easy to start an F.A.C. Flight or Squadron. Tell your friends and acquaintances about the F.A.C. and its official magazine, FLYING ACES. Ask them to get a copy of FLYING ACES. Ask them to join the famous F.A.C. Counting yourself, it takes a minimum of six members to form a Flight, eighteen for a Squadron. To become a member, each applicant must fill out and mail to G.H.Q. the application coupon. Be sure, when writing to Headquarters, to enclose a stamped, self-addressed envelope for your reply. This is important.

Honorary Members

- | | |
|--|---------------------------|
| President and Mrs. Franklin D. Roosevelt | |
| Casey Jones | Rear-Admiral Byrd |
| Wiley Post | Capt. Edward Rickenbacker |
| Al Williams | Colonel W. A. Bishop |
| Col. Scaroni | Major G. A. Vaughn, Jr. |
| Gov. Gifford Pinchot | Mrs. Gifford Pinchot |
| Major von Schleich | Willy Coppers |
| Lieut.-Col. Pinsard | General Balbo |
| C. E. Kingsford-Smith | Josef Veltjens |
| G. M. Bellanca | Amelia Earhart Putnam |
| Capt. Boris Sergievsky | Senator David I. Walsh |
| Colonel Roscoe Turner | Lowell Thomas |
| Lieut.-Col. Theodore Roosevelt | |

AWARDS AND HONORS

The D.S.M.

The Flying Aces Club Distinguished Service Medal is the highest award of the Club and is given to those whose work on behalf of the F.A.C. is "beyond and above the call of duty." It has been awarded for obtaining prominent men and women as Honorary Members, for exceptionally successful activity in the promotion of the Club, for outstanding work in covering the secret assignments of G-2.

Winners of the D.S.M. who merit further awards will be given beautiful bronze props. Worn on the ribbon of the D.S.M., they may be compared to the bronze palms awarded to winners of the Croix de Guerre. The highest award of the F.A.C. is the D.S.M. with three props.

The Ace's Star

The Ace's Star is awarded to regular members of the F.A.C. who have qualified for their Cadet and Pilot Wings and who have succeeded in enrolling five new members in the Flying Aces Club. Each new member must fill out the Application Coupon below. Get five of your friends to do this, send in their applications all together and win the F.A.C. Ace's Star.

Official Charters

F.A.C. Flights and Squadrons are recognized only when they have been awarded Official Charters. These Charters are illustrated to depict the various steps of advancement in aviation, and the wording is in keeping with the high ideals and purposes of the Club. They are printed on a very fine grade of paper and the names of the Squadrons are hand-lettered. Charter applications must always be accompanied by a complete list of members with their addresses. For the Flight Charter send 25c, for the Squadron Charter 50c, to cover costs.

Volunteers for G-2

G-2, the Inner Circle of the F.A.C., is open to a restricted number of members who are qualified for Secret Service activities. Those who are chosen will have unusual opportunities to win the Club's Distinguished Service Medal. Those who are accepted will be given a secret number and identification card as well as the secret code. Assignments will be made by letter and code.



COUPON No. 23

Save This Coupon for PILOT'S WINGS of the Flying Aces Club

All enrolled members who have already won their Cadet Wings are eligible for Pilot's Wings. This coupon, with four other similar coupons from any other four issues of FLYING ACES Magazine and 10c, entitles Cadets of the F.A.C. to Pilot's Wings. Do not send in this coupon alone. Save it until you have five of them. Then send them in all together with a self-addressed envelope and 10c to cover cost of wrapping and mailing. Only one pair of Wings to a member. If you lose yours, send 25c for new ones.

Canadians send International Reply Coupon for 15c. British send one shilling in coin or International Reply Coupon for one shilling.

COUPON No. 26



Save This Coupon for CADET WINGS of the Flying Aces Club

All members who have Official Membership Cards are eligible for Cadet Wings. This coupon, with two other similar coupons from any other two issues of FLYING ACES Magazine and 10c, entitles members of the F.A.C. to Cadet Wings. Do not send in this coupon alone. Save it until you have three of them. Then send them in all together with a self-addressed envelope and 10c to cover cost of wrapping and mailing. Only one pair of Wings to a member. If you lose yours, send 25c for new ones.

Canadians send International Reply Coupon for 15c. British send one shilling in coin or International Reply Coupon for one shilling.

January Application for F. A. C. Membership

I, the undersigned, hereby make application for membership in the Flying Aces Club. I agree to live up to its rules and regulations; to foster the growth and development of aviation; and cooperate with all other members in the work of spreading aviation information, building up confidence in flying for national defence and transportation. I will aim to build up the Club and its membership, and do my best to win the honors that the Flying Aces Club offers.

My name is
Age
Street
City State

Mail this application, and with it, enclose a self-addressed, stamped envelope. Canadians send an International Reply Coupon worth 5c. British send a similar coupon worth sixpence.

FLYING ACES CLUB—67 W. 44th St., New York City

Flying Aces Club News

Happy landings on the Flying Aces Club tarmac this month, F.A.C.'s! News comes from near and far to share with you at this meeting. From Maine to South Africa, members of the ever-growing Flying Aces Club send in word of their activities. Let's see what has been happening.

GREETINGS, F.A.C.'s! We know that we don't have to convince any of you what a great thing it is to be a member of this, the biggest and only aviation club of its kind in the world. But some of you may be new members, and to them we want to pass along the good word from a squadron leader who knows that it pays to be an F.A.C. member.

Edward J. Cawley, leader of the Club unit at Dunmore, Pa., sends us a very interesting letter on this subject. "Many thanks for granting me permission to act as representative of the Club at the recent air meet held here at Scranton," he writes. "When I presented my letter and membership card, I was treated with the utmost courtesy by Mr. Harold Swank and other airport officials. The event was an air tour in which some fifty planes and more pilots participated. Frank Hawks, Casey Jones, Lt. Col. Vaughan and Richard Bircher of Philadelphia were a few of the better known pilots who took part.

"One of the most interesting ships there was the silver three-mile-a-minute Boeing Monomail 247, which, incidentally, was the first three-mile-a-minute multimotored passenger express transport ever placed in air line service. On this trip it was piloted by Lee Murphy and had as two of its passengers M. F. Redfern and E. D. McGlore. When I told Mr. McGlore I was from FLYING ACES, he had the graciousness to show me through his magnificent ship. I was certainly very grateful for his kindness, and for the kindness of Mr. Harold Swank of the Scranton Airport and the other officials of the United Air Lines."

Pennsylvania is a great state for F.A.C. activities. Colonel "Chuck" Davis writes us that his group is starting military training at their gatherings on Friday nights and Saturdays. Work is progressing steadily on Davis' motorcycle squadron, too, and he'll have more news for us next month. From the Philadelphia Squadron comes word from Major Charles Riley, who wants all members of the Club in the Phila-

delphia section to get in touch with him. Girls interested in starting a squadron should report either to him at 5926 Loretto Ave., Philadelphia, or to Miss Sally Elliott, 5208 Castor Road, Phila. Riley and Miss Elliott want to hear your ideas for a girl's uniform for the Club. Let's hear from you—or write to them direct.

Robert J. Thompson, of Toledo, Ohio, sends us interesting news. He is progressing nicely with his model museum, he says, and he encloses a letter of acceptance to honorary membership in the Club from Chet Fenton, manager of the Transcontinental Airport of Toledo. "I have been affiliated with flying since 1918," Mr. Fenton says, "and I appreciate the fact that the progress of aviation depends to a great extent upon the youth of the nation. Therefore it is to our advantage to help them in any way we can."

Speaking of projects like model museums, here's an idea, and one worked out by an F.A.C. member. It's a model airport, with planes, buildings, etc., put on exhibit in a department store in your town. Donald Campbell, who is organizing a squadron in Troy, N. Y., did this stunt with another F.A.C. in his group, and their exhibit has caused quite a stir in the town. That's something all you model builders can do, and it's one good way to arouse interest in the Club.

From "down in Maine" comes a plea for help. Major Earle Jepson, of Winterport, Me., writes us that he would like to hear from anyone interested in forming a state-wide F.A.C. Squadron known as the Maine State Eagles. Let him know about it, you F.A.C.'s from Maine!

This country isn't the only place in the world where things are humming for the F.A.C. Here is some hot news from foreign parts. The first Australian Squadron has been organized by H. M. Cameron, of The Crescent, Fairfield, Sydney 77 S.W., who writes us that he now has 20 members, and is still going strong. Cameron exhibits his own models in a local shop, and has on display a card inviting all to join the Club. Great idea! George S. Campbellton has a British Squadron at Chatham, Kent, England, and writes us that he and other members of his unit were recently shown over Gravesend Airdrome and Rochester Airdrome in the "teeth of a raging air circus, which we enjoyed." C. P. Street writes us from Queenstown, South Africa, that he has organized a Squadron. And from New Zealand comes word that the first New Zealand Squadron has been formed by Reg. Burke, of Weraroa, Levin.

Yes, from near and far they come, and more every month. Send us some good news, F.A.C.'s!

Claws of the Hawk

(Continued from page 6)

"Sorry, sir. It's a little cramped in here."

"We'll wait outside. Call me when he starts to recover his senses."

Sutton was the last one out.

"My .45's in that top drawer," he told the steward. "Get it out, in case he tries to start anything."

The man took the gun, and Sutton joined Mitchell outside.

"I don't suppose we'll get much out of that Jap," the C.O. said dourly.

"He probably knows plenty. He must have had some connection with their Intelligence, to spot that courier and us." Sutton stared into space. "I wonder whether he would have heard if K-4 were caught?"

"Your man must not be so hot, if he's let himself get spotted even before war is declared."

"Khiro is just as deadly in peacetime," said Sutton, gloomily. "He's got an enormous ring of international spies, ready for anything from war to high piracy."

"With a big mob like that, you'd think some one would sell him out to an enemy government."

"Not Khiro. He has a particularly horrible way of dealing with traitors, I've heard. Anyway, he's too well covered. Probably not ten of his own men know him by sight. He's a Eurasian, can pass for almost any nationality."

"Half-breed, eh? That explains his hating the white race."

"He's no ordinary 'breed.' According to K-4, the man's got the cunning of both bloods and the devilry of the mixture. The shrewdness of a Yankee, along with the slyness of an Oriental mystic."

"Your mysterious spy would have to be a wizard to get that bird."

"K-4 is no mystery," snapped Sutton. "Simply a well-trained agent. Brought up in espionage atmosphere and knows the tricks. His father was in Foreign Service. In addition, he's an expert fencer, and it's given his brain something—"

"I get it. An old fencing master at Annapolis once told me that if I'd learn the game, it would give me an edge on other people. Said I'd learn to use my mind like a foil."

"Yeah." Sutton glanced impatiently at the closed door. "That's what K-4 told me, said it sharpened your brain. He offered to teach me to fence. Come to think of it, I should have been insulted."

There was a sound from within.

"No insult intended, Sutton," said a voice. The door swung open, and an amused face, half-smudged with brownish stain, appeared in the entry.

"Hawk!" gasped Sutton. His homely face was a picture of stupefaction.

Mitchell, after a stunned stare at the completely unfamiliar features, saw the man's Japanese uniform. He jumped forward with an oath.

"It's all right, Commander," the man told him whimsically. "Sutton will explain—when he gets his mouth closed."

Would You be Interested in Getting an F.A.C. Uniform?

Quite a large number of inquiries have been received at National Headquarters about an F.A.C. uniform. We will be glad to adopt an official uniform if enough of you fellows want them. If you are interested, drop a line to the National Adjutant of the Flying Aces Club at 67 W. 44th Street, New York City. Be sure to enclose a stamped, addressed envelope for a reply. Tell him what kind of a uniform you would like and how much you would be willing to pay for it.

With an effort, Sutton recovered. "Yes, he's okay," he said. "It's K-4."

MITCHELL'S suspicious eyes flicked to the .45 in Hawk's left hand. The agent smiled, white teeth contrasting with the uneven brown of his face.

"I just borrowed it from our friend in there."

Mitchell shoved past him, flung the door wide. The hospital steward glared up from the floor, gagged with bandage rolls, arms tied behind him with his own belt.

"One of Khiro's men," Hawk said, easily. "He saw through that mix-up, and tried to stab me out on the catwalk, while your blood-thirsty crew worked on me."

"And we left you unconscious with him!" interjected Sutton.

"Not exactly. I had a glimpse in the dark, and I thought he was playing the rôle of hospital steward. I did a little playing myself, knowing you'd send for him. I didn't swallow that stuff he gave me. He thought I did and was out cold—so the rest was easy."

Mitchell was still ruffled.

"Why gag and tie him? We've no time for dramatics."

"Ounce of prevention." Hawk was gingerly rubbing the ribs where he had been kicked. "Otherwise, he'd have yelled before I could take off this stain. You'd have rushed in, plugged me for a Jap—and probably helped him toss me to the sharks."

A slow grin forced through Mitchell's sour expression.

"You're right. That's just what I'd have done." He gazed at Hawk's smeared cheeks. "I'd never have believed it. Your face was entirely different, even in shape."

"Stage tricks. Inlays to bulge the cheek bones. A little paraffin injection to widen my nose, and some stuff of my own to draw the eyelids into a slant—"

Mitchell started. "Your eyes are a different color!" he gasped. "They were black. I saw them when Sutton rolled back—" He halted as he saw the look Hawk sent Sutton.

"It's all right," Sutton said, eying the bound spy. "He won't be telling tales."

Hawk saw Mitchell's bewilderment.

"Fortunately for me, I'm the possessor of a peculiar optical trait. It's been called 'chameleon eyes,' the property of the cornea changing to correspond with surrounding color. Any but very dark eyes will do it slightly, but mine go the limit."

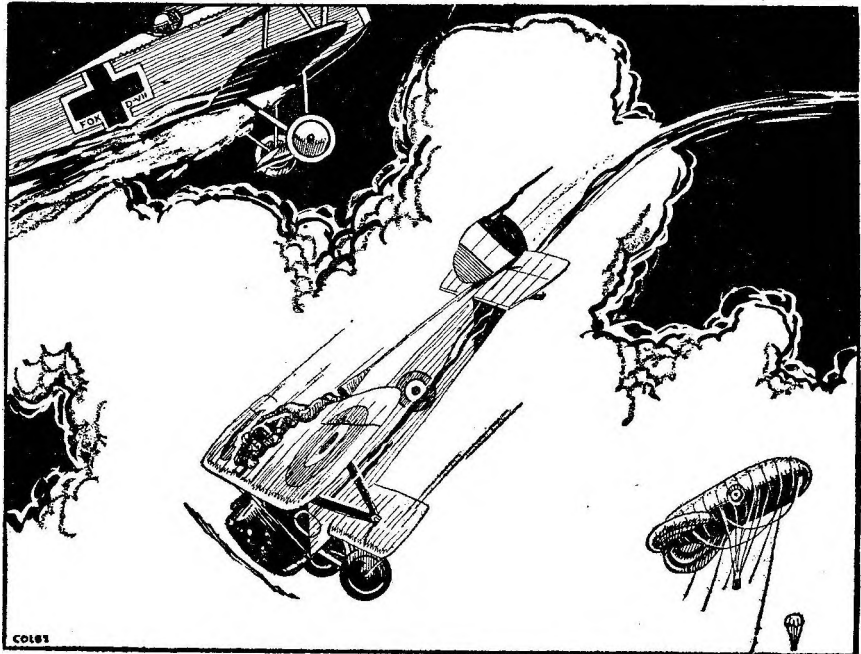
"That's how we found he could impersonate an Oriental," said Sutton. "That dark brown stain does the trick."

"For which thank Heaven," Hawk said grimly. "They were going over the *Osho* with a fine-tooth comb."

"You've been with their fleet?" Sutton exclaimed eagerly.

"Only the *Osho*. She and a small escort separated from the rest, for some reason. But I learned something. They're about ready to strike. Khiro was relayed to the *Osho* today, from a

MISSING WORDS CONTEST, No. 9



Win a Flying Scale Model of the LUSCOMBE SPORT PLANE

In Missing Words Contest No. 9

FIVE PRIZES

- First—Flying scale model of the Luscombe Sport Plane, popular model of today.
- Second—Regulation flying helmet and goggles.
- And Three Prizes—Kit for Sopwith Camel model—guaranteed to fly.

To Win This Contest:

In the above picture the artist has told a story—and the same story is told in words below. Some of the words have been left out—for example, balloon is the word missing from the first line of the story. What you should do to win this contest is fill in all the missing words to fit the picture above. Send us the list of missing words, in their correct order, with a letter telling us whether you have any difficulty in finding copies of FLYING ACES at your newsstand, and whether it is prominently displayed.

Here's the Story:

At the end of a long rope, there hung above the battlefield a..... upon whose sides gleamed the tricolored insignia of the..... Above it, guarding it from enemy planes, darted a French..... The insignia of a flight commander was streaming from its..... and struts. Suddenly the pilot saw approaching a wicked-looking..... As it drew nearer, he noticed that it, too, was piloted by a..... Instantly the Nieuport pilot headed for the oncoming enemy..... while from the balloon below him there dropped a billowing..... Both the pilot of the German ship and the pilot of the..... were holding their fire until they were within range of their..... Both began firing at the same time, the Allied pilot's top..... also spurring lead from the Lewis gun mounted there over the..... So intent were the two pilots that they did not see how..... they were to each other. The Allied pilot at the last minute..... his little ship just in time to avoid a head-on collision. The..... zoomed up and over him, but not until too late. A sheet of yellow..... belched out from beneath the fuselage, followed by clouds of black..... Turning over in the air, the enemy plane fell, a flaming torch, to the..... Meanwhile, the Allied pilot was having trouble of his own. The sudden..... of his ship had caused his safety belt to break, tossing him out of his..... and out of the cockpit up onto the little French ship's..... Fortunately for him, he could grasp the mounting of the..... and then work his way back into his seat. Returning to the..... he once more took up his circling protection, while the..... back in the basket below the balloon, once more, waved a message of.....

Don't Forget:

The winners of the contest will be judged by the correctness of their list of missing words and by their letters. All decisions by the judges will be final. Be sure to mention in your letter the name and number of this contest, and the issue in which it appears. All answers on Missing Words Contest No. 9 must be mailed by the time the next issue of FLYING ACES is on sale. Send to

Missing Words Contest No. 9

FLYING ACES Magazine

67 West 44th St.

New York, N. Y.

war council. He's flying for the West Coast, to take charge of espionage all over the States."

Hawk picked up a wad of cotton, soaked it in alcohol from the first-aid kit. He talked swiftly as he wiped the stain from his face, throat and hands.

"I got wind of the first move, blowing up the *Macon*—"

"What?" shouted Mitchell.

"Didn't you see that stolen Curtiss explode? It was loaded with H.E. The Japs evidently decided to sacrifice this spy. That pilot was a Jap set to commit hara-kiri—and take you with him."

"How did you get away from the *Osho*?" demanded Sutton.

"Volunteered to follow and report that the plan worked. I knew it was set for a 5:30 contact. They had this spy here to insure the hook-on by faking a radio order in your new code, though he probably thought it was just another spy coming."

"That copy on the pad was planted," Sutton told the C.O. glumly.

"I hadn't enough gas left to reach our fleet when the scrap was over," said Hawk. He began to peel off the Japanese uniform. "It was get on here or nothing. By the way, I'll need something in place of this outfit."

SUTTON brought a uniform from his small locker. Hawk seemed, subtly, to change as he put it on—a custom of carefully playing each rôle, to which he had rigidly schooled himself for several years. His alert, clean-cut features were now those of a typical naval officer, except that his eyebrows still were a trifle too dark from the residue of the dye.

He had squeezed the paraffin injection from the sides of his nose. The width at the base was gone, leaving his nose straight and even. As the brown stain disappeared, his eyes had gradually turned to a tawny hazel.

But there was one thing which had not changed—the glittering pupils of Hawk's eyes, which even in repose shone like bits of hard, black ice. More than one man, misled by the easy humor of the secret agent's natural face, had brought up with a start before those black pin-points.

Hawk turned to the C.O.

"I've got to have one of your defense planes, commander. I've learned the location of Khiro's secret headquarters on the West Coast. If I work fast, we can capture him and his main agents, and crush their spy web."

The man on the floor had stiffened. Hawk eyed him briefly. Mitchell gave a reluctant nod.

"An engine was already warmed, during that fight. I'll have it started again."

"One second." Hawk took a small pad from Sutton's locker shelf, wrote quickly. "The *Osho* knows about where you are," he said as he scribbled. "This spy radioed them. I caught it on the Mit-subisi's set. To be safe, I'd send this fake S.O.S., breaking it as though—" Hawk finished the message and handed it to Mitchell.

As the C.O. vanished, Hawk closed

the door and abruptly jerked the gag away from the spy's mouth.

"I'll give you one chance for your life," he said calmly. "Every scrap of information on the Jap plan and Khiro—or you go over the side."

The lantern-jawed spy sneered up at him. "Childish work! That fool of a commander is too much of a stickler for regulations—"

"Make your choice. This officer with me can tell you that I have special authority."

Sutton squirmed uneasily. "That's true, Hawk, but—"

Hawk stepped to Sutton's locker as the faint drone of a fighter engine rose over the airship's muffled exhausts. "I'll borrow your flying-suit and gear. By the way, I forgot to warn them not to show lights around that plane bay. Will you go tell them?"

Sutton nodded somewhat curtly, departed. Hawk shut the door, swiftly picked up the .45 he had laid down. A frightened look erased the spy's sneer.

Hawk roughly rolled him over and unfastened the belt. As he finished, the buzzer sounded. He backed to the phone.

"Hello . . . All right, swing it out . . . I'll be there in a minute."

The spy was slowly getting to his feet, rubbing his wrists. As Hawk put down the phone, the man turned into a human dynamo. In a tigerish leap, he wrested the pistol from Hawk's hand and sent him crashing across the tiny room. Hawk groaned as his head hit a girder. He slid down in a heap, eyes closing.

The spy waited tensely. Then, as Hawk lay motionless, he whirled back and pulled Sutton's helmet and goggles over his head. In a few seconds he had the flying-suit zippered tight. Hawk watched him through barely slitted eyes. The spy cut the phone cord with his knife and turned, hesitating. Hawk's eyes almost closed.

Then he heard the door open and shut, the lock snap. He was on his feet, rubbing his head, when the lock rasped and Sutton sprang inside.

"It worked?" Hawk said hastily.

"He's headed for the plane—but what's the idea?"

"Come on." Hawk ran aft, Sutton behind him. "He's swallowed it perfectly. I never had the slightest idea where Khiro's hideout is. This way, he'll lead me to it."

The darkness of the catwalk slowed their steps. An engine roared as they neared the bay. Its sound died away. Hawk ran toward the launching room, saw the open trap. Mitchell appeared.

The second fighter was started, hooked on for launching. Hawk jumped into a flying-suit which a pilot brought on the run.

"I'll send back two planes, Commander, and get word of this to Fleet."

The C.O. nodded. Sutton followed Hawk toward the plane.

"I still think you're crazy. What if that spy had decided to shoot you?"

Hawk grinned. "I unloaded the gun," he said.

He swung into the cockpit and

snapped his safety belt. With a wave to Sutton, he set himself for the drop.

Swish! The little fighter plunged into space. Hawk let it fall three hundred feet. Then he backsticked and swiftly climbed.

CHAPTER II

SATAN'S SMOKE

AS the F-9 roared up in the darkness, Hawk shrewdly estimated the spy's movements. He headed east, the approximate course to the nearest land, then leveled out as he reached the clouds. Skimming under them, he peered alertly below and from side to side. In a few moments, thinking himself safe from pursuit, the spy ought to . . .

The expected glow came quickly, as the spy used his cowl light to read his map. It was only a faint yellow spot, but Hawk kicked down and behind it in a twinkling. The spy set his course, switched off the shielded light. Hawk followed by watching the exhaust flares, checked his compass and the speed, then dropped back to read his own map. His eyes glittered back of his goggles. He dived steeply, and at a hundred feet above the waves, the little fighter hurtled toward San Francisco.

An eternity dragged past, as the F-9 roared through a black void. Hawk put on his oxygen-mask to shield his face.

Thirty miles from shore, by dead reckoning, he switched on his two-purpose radio. Brief code signals rattled in the helmet phones, evidently routine flash reports from the extended scout vessels and air patrols. Fleet itself seemed silent, also KPO and the other San Francisco stations. It was obvious they were taking no chances on guiding enemy bombers in a surprise night attack. He tried Seattle, Portland and Los Angeles, as well as smaller West Coast cities. They, too, were dead, but suddenly he caught a series of dashes in his phones, followed by a letter "U."

He listened, surprised. This was the radio beacon signal from KCV, the airways station at Oakland. It was odd that everything else should be shut down and this certain guide be left.

Hawk gazed sharply to his right. A tiny point of green light was flickering in the darkness. Almost in the same moment, another and brighter green light showed ahead, and the phone signals ended abruptly. Quickly suspicious, Hawk pulled up for two hundred feet as the first green light neared the second. It might be coincidence, but it looked as though the plane ahead had been sending out a false "beacon" signal to lead the other ship toward it.

They might be Fleet patrols, but it wasn't likely. The big Martin boats would be flying low, dropping flares now and then to illuminate the sea. And the fast scouts would be high up, hugging the ceiling above the clouds. Hawk stared as the two green lights moved along close together. There was something twisting down in the darkness, something which shone like writhing, golden snakes.

Then he realized, abruptly, that it

was a rope ladder, treated so that it was luminous. He reached forward and swiftly charged the twin Brownings. Zooming above the green lights, he snapped a small parachute flare from the tube under his seat.

Yellow brilliance burst out beneath him. Clearly revealed were the wings and cabin of a Douglas "Dolphin" amphibian. As Hawk banked around, he glimpsed the words "U.S. Coast Guard" on the side of the hull near the tail. He cursed himself; evidently he had meddled into some official mission.

Then an electric shock went through him as he saw the plane under the Douglas. A Nakajima ship-plane fighter! But more than that—it was the black Nakajima which Khиро had flown from the Osho!

Khиро! Then there were traitors or spies in that Douglas. They had come to take the spy master ashore under cover of those Coast Guard markings.

The black Nakajima dipped and plunged toward the sea. Hawk jammed his stick forward, then hauled back with a clipped oath. Khиро was on the rope ladder! The plane was empty.

A trap was flung open in top of the Douglas' cabin. A gun swiveled toward the F-9. Hawk kicked out, and the first blast hammered into his wings. He tripped the Brownings, raked the amphibian's gunner. Another fusillade gouged the F-9's turtleback; then the spy-gunner tumbled out of sight.

KHIRO was scrambling into the cabin, helped by men inside. Another machine gun rattled into action, seared the air around Hawk's head. The Douglas whirled onto its heavy wing tips, leaped for the darkness away from the flare. Hawk pounded a burst into the tail, swept it toward the pilots in the bow.

Suddenly the F-9 trembled. Tracers streaked down from the sky above the flare. Bullets beat like the pound of a riveter, back of Hawk's cockpit. He stood the fighter on its tail, half-rolled as he went up. Two gray Nakajimas screamed in at him, Vickers pumping flame.

Below, the black Nakajima suddenly burst into flames. Even as Hawk loosed his guns, he caught the reason for that fire. It was a device set by Khиро, to leave no trace of a Jap plane so close to shore.

T-t-t-t-t! The Brownings panted fiercely, stabbed a double hail of .30-.30's into the first Nakajima. The speedy Jap ship whirled, was out of range in a flash. The second Nakajima screeched in, over-shot as Hawk chandelled. Before the Jap could reverse, Hawk had him in his sights.

Trip hard against the stick, he poured a deadly torrent into the swiftly banking ship. The Brownings' tracers leaped to the Jap pilot's pit. The Nakajima jerked sidewise, rolled crazily. Hawk had no time to make sure of the kill. The F-9 snarled up and around in a climbing turn. For an instant his spouting guns crossed the cowl of the diving Jap. He twitched the rudder, saw the pilot suddenly stiffen.

Mortally wounded, the Jap pitched in

under the flare, straight for the little fighter.

Hawk jammed the stick hard down. With a mounting shriek the F-9 whirled on into an outside loop. The wounded Jap streaked past above him, with hardly five feet to spare. As the gray plane howled down into the night, the other Jap savagely struck. Hawk rolled hastily right side up. Tracers from four Vickers were smoking from the ship he thought he had crippled.

The Jap's faster ship skidded as he tried to cut inside the turn. Hawk boot-ed his rudder. The Nakajima was a pivoting shadow, well away from the light. Its four guns winked out viciously; then Hawk's tracers ripped up past the tail. The slower F-9 snapped to a vertical bank. Too late, the Nippon pilot saw that his speed had trapped him.

Wings straight up and down, the Nakajima pitched full under the greedy Brownings. The Jap's hands flew up from his controls. He quivered under that blast of doom, then sagged down onto his stick. As the Jap ship dived, Hawk saw two blobs of flame below. He watched, but the last Nakajima did not burn. The Nipponese had had no time to set off the device.

Hawk banked sharply as a searchlight pierced through a gap in the low clouds beneath. The Dolphin might still be near him. But no guns chattered, as the shifting light briefly revealed the F-9. He stared down, saw another beam probe through patchy clouds. Destroy-

ers, probably. He had no time to signal them now. He sent the little fighter roaring toward land. His original plan to trap the spy from the *Macon* was now forgotten. If he could seize Khиро—or kill him—it would ruin the whole Japanese spy system. He was the key.

Key! The word drove Hawk into swift action. He switched on the radio again. Now the air was alive with frantic messages in code. Fleet and shore were flashing stand-by alarms. The fight had been taken for the first action of a night-bombing raid. He heard a grating voice on the KGO wave-band, from Oakland:

"All but military lights out, under penalty of martial law. All private motorists off the streets . . ."

Hawk cut in his transmitter, set it to 332, for KCV at the Oakland airport. The Oakland field, he knew, was combined headquarters for Army and Navy air forces. He switched from microphone to the sending key, began to hammer a call.

Hardly five seconds passed before KCV answered—by voice. Hawk swore, seized his mike.

"To Captain Barry, Naval Intelligence. Tell him Khиро is in Coast Guard Dolphin heading to shore."

AS he switched back to the phones, a deafening roar came into Hawk's ears. He jerked the plug loose, cut down the volume, listened again. **A**

EXTRA! EXTRA!

In the Next Issue of **FLYING ACES**

THE WAR OF THE PACIFIC

*Sensational Japanese Novel of a Future War with America
By a Retired Officer in the Imperial Japanese Navy*

Suppressed in the United States!
Withdrawn from circulation in Japan!
Now presented for the first time to
American readers in an abridged translation

By Dana R. Marsh

Also

Stories by Joe Archibald, Harold F. Cruickshank
and Others

Articles by Arch Whitehouse, Charles S. Strong,
James Perley Hughes and Others

Model Plans of the Northrop Victoria,
U. S. Coast Guard Flying Boat,
Flying Aces Outdoor Stunt R.O.G.
F.A.C. News, Snapshots of the War
and Many Other Features

In the
February **FLYING ACES**

On Sale
December 24th

baffled light came into his eyes. Khiro's men had started to hash the air with artificial static. Probably KCV hadn't caught more than the first of that message. He tried another setting, found it the same.

Hawk nosed down, thundered toward the Golden Gate in a power glide. The Dolphin's top speed was 151, and the F-9's 178. He still had a chance, unless the spy-master swung up or down the coast.

The Whirlwind 420 took the fighter down in a thunderous dash. Hawk leveled out at 2,000 feet. A light sprang out of the gloom, shifted up at him. Another destroyer! In a few minutes the sea was alive with them, lights leaping up to north and south. Ahead, more searchlights blazed from the Presidio. He climbed as his hurried glance failed to show the amphibian.

San Francisco took form ahead, a dark mass except for the waving searchlights. There was spotty fog over the bay, some over the city. He saw a dozen flitting specks shoot out from the direction of Oakland, drill through the lights as they climbed. Boeing P-12's—Army ships rushed up for defense against the supposed raid. Another double V followed the first.

Hawk twisted out of a tenacious beam and headed for Oakland, a few miles away. More searchlights were slashing up from the huge terminal airport. One of them blinded him for a moment. He pulled up, waiting for his vision to clear. Suddenly there was a great flash of violet in the sky above. He stared up, saw Boeings wildly milling, one of them out of control.

The falling ship slithered through one of the myriad searchlights. A thin plume of purple smoke eddied after it, yet the plane was not on fire. As Hawk watched, there came another splash of bright purple high up in the heavens. He jerked his throttle, heard a dull concussion. The next moment, fire gushed out where the purple light had been. Another stricken P-12 plunged earthward.

By this time, the searchlight crews below had gone wild. A hundred brilliant beams stabbed at the sky. Hawk kept looking up—the only way to save himself from being blinded. The rest of the Boeings were scattering in all directions. One ship screamed down past him, the pilot silhouetted in a light ray, a microphone at his lips. Hawk switched on his receiver. Words crackled into his ears:

"Break formation. Get out of the lights. It'll get us all if we stick—"

Then another, calmer voice said, "Rendezvous over San Bruno. Calling KGYO. Cut all lights on field—"

Hawk jerked erect. That smooth voice—there was something familiar. . . .

"Khiro!" he snarled. He hit his transmitter switch. "Watch out, Boeings! It's a trap—"

For the second time that night a roar dinned into his ears as the air was suddenly hashed. Colored rockets lanced up from the Oakland airport. Those were frantic signals to the Boeing

pilots, Hawk guessed. The searchlights swiftly began to fade.

The burning Boeing was moaning down almost in Hawk's path. He banked sharply, then tensed as something swung out of the sky at his left. One of the remaining searchlights caught the thing and held it. A man in a parachute became visible. Hawk ruddered to give the swaying figure plenty of room. As the F-9 roared past, the face of the Army pilot was discernible in the dazzling beam.

The next instant, purple flame leaped up and hid the man's face from Hawk. A little cloud of violet smoke eddied upward. As it cleared, Hawk gave a horrified gasp.

The pilot's head had been blown from his shoulders!

As Hawk watched, sick and dazed, he saw the half-burned shrouds give way. Like some gruesome dummy, the headless corpse fell over and over toward the earth. The parachute collapsed and flapped dismally down the sky.

Still stunned, Hawk sat gazing into the now almost dark heavens. Not a thing was in sight, but some grim premonition came to him that he was in danger of that same horrible death. He turned quickly to dive for the Oakland airport. Only two searchlights now probed up from the field, though across the bay a score of them flicked back and forth above San Francisco. He was shoving the stick forward when his ears caught a rattle of gunfire above.

He twisted around in his cockpit. Tracer lines were shooting through the sky overhead. Suddenly a familiar shape dived through the edge of a light beam.

The Coast Guard Dolphin!

CHAPTER III

THE "K" GROUP

THE amphibian was plunging toward the bay, toward the heart of a fog-covered stretch. Two Boeings were pitching down on its tail, guns blazing.

Hawk's gas was almost gone, but he pulled up and charged out over the water. The three planes roared down ahead of him. Sub-machine guns were hammering from the Dolphin's windows, and a Lewis flamed from the trap in the top. One of the Boeings yawed under a deadly blast, spun off with smoke pouring behind it. Hawk clenched the twin-gun trip on his stick. The Brownings snarled eagerly, ripped slugs into the nose of the Dolphin.

The amphibian kicked onto its left wing, dropped precipitously. Hawk thought he had crippled it, but as he dived after the ship, it swiftly straightened, roared for the fog-covered bay.

The remaining Army pilot had plunged headlong till he was under the Dolphin. With a dizzy zoom, he flashed up to gut the Coast Guard ship from beneath. Suddenly the Boeing lost its arrowlike drive. The right wing dropped; then the P-12 rolled wickedly. Half-stalled, it twisted past Hawk, nose pointed crookedly upward.

"Good God!" Hawk cried hoarsely.

A weird purple haze was beginning to cloud around the pilot's head. The man staggered up in his cockpit, clawed at his face with suddenly smoking gloves. Then his knees seemed to buckle. He fell sidewise over the cowl.

As he fell, a wave of violet flame swept over him, whirled back toward the tail of the ship. The P-12 danced in a purple mirage, then abruptly was on fire.

Horror and consternation held Hawk spellbound for a moment. He recovered barely in time to see the Dolphin level off at the edge of the fog-covered area. He thrust the stick down, and the F-9 screeched toward the bay. Only the tail of the Dolphin was visible, but he ringed it in a flash. The Brownings leaped upon the cowl, spewed hot cupro slugs into the vanishing ship.

Then the fog whirled up, and he was forced to level out. Through a thin spot he glimpsed the Coast Guard plane, slowing to a stop. The Lewis gunner saw him at the same second. The gun swiveled up, hurled a venomous torrent into the flitting F-9. Bullets crashed through the floorboards, tore the crash-padding along one side of the pit. Hawk tilted the nose, but before he could fire again, the fog had swallowed up the Dolphin.

He banked at two hundred feet, and saw the tiny searchlight of a harbor police boat sweeping across the water. The boat was dashing toward the edge of the foggy stretch. Another boat was racing out from the seaplane anchorage of the Oakland airport. One of the airport searchlights was slanting over the water, trying to pierce the billow of fog.

The Whirlwind skipped a beat, picked up its roar again. Hawk tensed. He had only a few seconds left. But if his guess was right, there would be a boat waiting.

T-t-t-t-t-t-t! From the other edge of the foggy patch a gun chattered fiercely. There were no tracers, but Hawk saw the dark blur of a fast motorboat which had come out almost in the police boat's path.

The police boat swerved, plunged into the fog as the other boat disappeared in the mists. Hawk kicked down in a grinding turn, fingers on the trip. His hunch was speedily justified. The first boat reappeared, lined out at furious speed for the darkest part of the bay.

Hawk pounced with the swiftness of his namesake. The metal belts whirled through the spouting guns. He saw the tracers hit the water. He pressed the rudder, drove a raking blast the full length of the boat.

The boat lurched, and he saw a figure hurled into the bay. For a second, the light from the Oakland field swept over the spot. He saw a sprawled form half over one gunwale, another man crouched down at the wheel. Then the Whirlwind sputtered and quickly went dead.

With his last bit of speed, Hawk tried to crash the fighter down on the fleeing boat. The man at the wheel made a frenzied turn and raced away. The F-9 stalled at ten feet, as Hawk saw that he had failed. He snapped his belt

open, pulled the stick clear back.

The fast little ship dug its nose into the water and crashed clear onto its back. Hawk was thrown headlong. He hit with stunning force, came up gasping, tearing off his flying-suit with frantic hands. Thanks to the zippers, he was out of it in a few moments. He swam back to the wreck. He had had no time to release the chemicals to fill his flotation bags, but the ship had not quite sunk.

CLINGING to a crumpled wing, he loosened his boots, pulled off his blouse. Then he struck out toward the boat from the Oakland airport. He was within two hundred feet of it when the bow of the police boat loomed from the fog. Too breathless to shout a warning, he kicked around to swim clear.

But the police-boat pilot had already seen him. The spotlight dipped toward him. A bell jangled and the boat slowed. At the same time, the boat from the airport curved in, and by the spotlight's rays Hawk saw that it was a Navy gig. Behind it came a Navy speedboat of the type used by officers on battleships.

Two of the police-boat crew reached down and hauled Hawk from the water. A sour-faced sergeant glared at him, a gun poised in his hand.

"Talk fast!" he barked. "Who are you? What the hell—"

"You're letting an important spy escape!" Hawk broke in, panting. "He's in that boat—the one that fired on you."

There was a bump as the Navy gig came alongside. A plump, red-faced four-striper sprang onto the police boat and hurried toward where Hawk stood.

"Is this the man who crashed—" The four-striper stopped short, gaped at Hawk. Hawk's face was inscrutable, though he had recognized Barry, his Navy chief, at first glance. With an obvious effort, the Navy Intelligence captain recovered his tongue. "Who—who are you?" he demanded.

Hawk remembered his discarded blouse, floating in the spotlight's glare not far away.

"Lieutenant-Commander Sutton, sir. But there's no time to waste. There was a spy in that Coast Guard plane. Unless he was killed or is back there in the fog, he got away in that motorboat."

Captain Barry gulped. Hawk saw that he had guessed the identity of the spy he refrained from naming. The four-striper pivoted toward the truculent sergeant.

"We'll get into the gig, so you can chase that spy. I'll flash an alarm by radio and phone as soon as we get ashore."

The suspicious look still lingered in the sergeant's seamed and leathery face.

"You're sure this bird is all right?" he growled.

"I'll be responsible!" snapped Barry. "Get moving, or I'll put a Navy crew in charge here!"

The sergeant swore under his breath and trotted back to the wheelhouse. Hawk followed Barry over the side into the gig.

"Where'll I bring those birds, if I

catch 'em?" the sergeant bawled after them.

"Air Staff Headquarters, Oakland airport," Barry shouted back. "We'll search in here to be sure no one's left in that plane."

"Nobody but a stiff," grated the sergeant. He gave an order, and the police boat ploughed away, spotlight roaming from side to side.

Barry drew Hawk back into the stern-sheets of the gig. As soon as they were out of the crew's view, he gripped Hawk's hand excitedly.

"Good Lord, man, I'd given you up for dead! How on earth—" Then his expression swiftly changed. "That was a *Macon* plane, wasn't it? What's happened?"

"No immediate danger," Hawk assured him. "At least, not a fleet attack. And I don't think they're close enough to launch bombers, either. But this Khiro business—"

"Khiro! Then that message wasn't a fake!"

"I didn't think you got it. They jammed the air—"

"I know. I was afraid it was a trick to get us to shoot down one of our own planes. It's happened once already, and then this other hellish business—" Barry's voice thickened. "You saw it—the way those planes were set on fire?"

"More than that. I saw one man's head blown clear off his shoulders, and another practically turn into purple flame."

Barry nodded, his usually genial face wan and strained.

"It's some devilish kind of ray, I'm afraid. It's brought down a dozen ships, killed people right through the fog, on San Francisco streets—and it's causing a reign of terror even before war is declared. God knows what it'll be like afterward, with a weapon like that in their hands."

"There'll be no declaration of war," Hawk said grimly. "They're waiting for something. When they're set, they'll strike faster than a cobra. If we could only have seized Khiro—"

"That police sergeant said there was a dead man in the *Dolphin* wreck," broke in the four-striper. "It might, by a miracle, be Khiro himself."

"Too much to hope," muttered Hawk. "But we can search."

"I'll have the other boat crew look for it. I've got to get ashore, and I want a full report from you."

HAWK waited till Barry had given instructions to the men in the speedboat.

"You're going to be disappointed," he said, as the gig sped toward the seaplane basin. "I've only a little information." He explained briefly his flight from the *Osho* and what had followed.

"At least, we know they haven't slipped through our outer patrols," said Barry. He looked at Hawk's dripping clothes as the boat reached the dock. "I'll get you something dry to wear, but to save time, you'd better go straight to see General Lunt. He's senior man of the Air Staff, now that we've temporarily combined Army,

Navy and Marine air forces. He'll want a report on the *Mirahota* affair. I suppose the Japs are using that as an excuse for attacking America?"

Hawk nodded as he followed the four-striper to a waiting car.

"It was a frame-up, of course," he said. "They figured the old plane-carrier couldn't keep up with their fleet, decided to burn it and make out that that American agent, Johnston, did it."

"But he admitted it. I saw the G.H.Q. copy of the Jap newsreel—"

The pupils of Hawk's eyes glittered with cold anger. "More of Khiro's work," he interrupted. "Johnston was drugged, then hypnotized. It's a trick Khiro has used before, as I well remember!"

The car rolled past the administration building.

Hawk saw soldiers everywhere, AA batteries along the borders, machine-gun and searchlight trucks lined in all directions. The car went between two hangars and stopped a little farther on.

"We've had an underground headquarters built, a regular fort," explained Barry, as they got out. "Communications are all below, to be safe from raids."

Hawk followed down a spiral stairs, through a gas-lock chamber, into a series of dugouts connected by passages. Walls, floors, and ceilings were of concrete, and between the ground fifty feet above were massive slabs of concrete and interwoven steel. Officers of the three services swarmed to and fro. He heard a furious hum from the communications room.

There was only one man with General Lunt when they reached his office. This was a tall, pleasant-looking colonel. The colonel's eyes met Hawk's with a momentarily startled expression, then changed to a look of seeming curiosity. Lunt did not notice. His stern, deep-set eyes were glowering from under a forbidding brow at the Navy captain.

"Well, so it's happened again! This ray, or whatever it is—" Then he saw Hawk's dripping clothes.

"Who's this?" he demanded. "What's happened?"

Barry hesitated imperceptibly. "One of my men, sir. He was bringing a report from the *Macon* when he ran into a spy plane—"

"Spies! Spies!" roared Lunt. "It's all I hear. Both you and Manning, here, admit you know the head of this spy ring, the man back of all this devilry—and you can't arrest a single one of his men."

"If you'll wait—" began the four-striper, bridling.

"Wait, nothing! I'm handling this thing myself. It'll probably surprise you gentlemen to learn there's a special unit of five men organized just to get this blasted Khiro."

Barry and the colonel exchanged glances.

"I thought so," snorted Lunt. "Well, thank God I keep my ears open! I dragged it out of the Chief of Investigation, Department of Justice. He has one agent in the group. So have Army,

Navy, State and the White House Secret Service unit. All five of those men know your great spy-master by sight. Why in Hades you never heard of them—"

"Just a moment, general—" said Manning politely.

"Shut up! I'm just letting you know, so you'll keep hands off when this 'K' group shows up. I've flashed word to Washington to rush them here by plane."

Manning rubbed his chin. There was a ghost of a smile on his lips.

"You won't have to wait, sir. The 'K' group is already here."

"What?" bellowed Lunt. "Then why—where are they?"

"Here," said the colonel. He gestured toward Hawk.

Lunt turned a tomato red. "Another crack like that—" he began.

"I'm not joking, sir. Captain Barry will tell you the same thing. The 'K' unit is just one man—Michael Hawk."

Lunt sat back heavily. "Well, I'll be damned!"

Hawk smiled. "Sorry I'm not more people, general," he said.

"What's all this tomfoolery about?" growled Lunt. Manning interposed an explanation before Hawk could speak.

"This is highly confidential, of course, sir. Hawk is the only American agent who has seen Khiri without any disguise—and lived to tell of it. Khiri tried to blot him out later, and made things so hot that Hawk created five separate identities in which he could lose himself. He's been used in the man-hunt for Khiri, ever since we found he had agents scattered through the United States and working against us abroad."

"You mean this man works with all five of those departments?"

"When occasion warrants it, yes. He's K-1 when on White House missions, K-2 for State Department, and so on. By starting a rumor that there were five 'K' men who had seen Khiri at one time or another in various parts of the world, Hawk has diverted part of the attention from himself."

Lunt eyed Hawk with the hint of a sneer.

"I suppose you carry five sets of false whiskers with you, so you can fool people."

Hawk ignored the tone. "Not quite that bad," he said. "It's mainly control of the facial muscles, and changing the voice, mannerisms and walk. Just a matter of remembering which part you're playing at all times."

"Humph," growled the general. He changed the subject abruptly to the *Mirahota*. Hawk told him what he knew, added a brief description of war conditions at Tokio and on the *Osho*.

"They've apparently spread their ships so our patrols couldn't spot their fleet, even if they sighted one or two vessels," he concluded.

Lunt nodded gruffly. Hawk went out with the two Intelligence officers. Barry found him an ensign's uniform. As Hawk finished putting it on, Barry's aid hurried into the four-striper's office.

"They've towed that Coast Guard plane into the channel, sir. There are two bodies. They found one in the water."

"I'll go look at them," Hawk told Barry. He turned suddenly at the door. "That other F-9—I'd forgotten for a minute—"

"I'll start a dragnet to working," said Barry.

CHAPTER IV

THE RED GHOST

HAWK found the bodies laid out near the seaplane ramp, at the south end of the airport channel. Neither bore a likeness to Khiri, but he examined their faces carefully to be sure that a skillful alteration of features had not deceived him. He was about to re-enter the car he had used when he saw the harbor-police boat swing in from the bay. In a few minutes the hard-looking sergeant stepped ashore, followed by another bluecoat.

"Any luck?" demanded Hawk.

The sergeant swore. "No, th' lousy rats gave us a run-around. We spotted the boat just as they hot-footed it up a ladder by a warehouse dock—"

"Which side of the bay?" Hawk rapped.

"Oakland. We opened up on 'em, but they got away clean. There was two of 'em, and I think one had been nicked—"

"Come on!" exclaimed Hawk. He jumped into his car, motioned both men to follow. As they raced for the Air Staff dugout, he hastily questioned the sergeant. "You can give the location of that dock, for an alarm broadcast?"

"Yeah, and what's more, I got th' number an' name of that boat. I can check th' owner by phonin' headquarters."

"How about that stuff ya found in the boat?" said the other bluecoat. "Maybe this Navy guy—"

"Give me time," growled the sergeant. "I was goin' to tell him." As the car halted, he produced what appeared to be a large toilet kit rolled up in thin oilskin. "We gotta keep it for evidence, but I thought maybe you'd want to see it."

Hawk unrolled the packet as they went down to the underground headquarters. His eyes roamed over pockets containing tubes of stain, special greaseless make-up coloring, paraffin and spirit gum. Other pockets held crêpe hair twists, scissors, powder, and a hypodermic syringe for inserting paraffin under the skin. As he was snapping open the larger buttoned pockets, Captain Barry appeared at the foot of the stairs.

"What did you find about those bodies?" he asked anxiously.

"Neither was Khiri, but we're close on his trail," Hawk explained tersely. "This kit was undoubtedly his. If you'll help the sergeant flash an alarm to the Oakland police—"

"This way!" Barry took the sergeant toward the Communications section.

Hawk went to Barry's office, the other bluecoat trailing along. Barry's aid was just coming out.

"They got that spy from the *Macon*," he said with a trace of excitement. "He ran out of gas and bailed out near the edge of town. Police in a radio cruiser had heard the tip, and they grabbed him."

"Fine. Have them bring him down here as soon as they arrive."

Captain Barry and the sergeant returned in a few minutes. Hawk was gazing at a bit of red silk mesh he had taken from the make-up kit.

"What's that?" asked Barry.

Hawk held it up before his face. Small eyelets became visible.

"It's Khiri's famous mask," he said tensely. "The one he uses to shield his identity when he meets his agents."

Barry looked at the thing in awe. "So that's where he got that name, the 'Red Ghost.'"

"Maybe. Or from the assassinations he's supposed to have engineered. Look at these." Hawk pointed to several small aluminum vials. "Poison—liquid and tablets. And this dagger—" he held up a tiny glittering blade—"There's a poison recess in the handle, and the blade's hollow so the stuff can be forced out at the tip. Nice traveling equipment!"

The four-striper and the two policemen stared at the dagger. A dubious look crossed the seamed, leathery face of the sergeant as Hawk began to fold up the kit.

"I dunno whether I want t' carry that or not. Sure none o' that poison can leak out?"

"No, it's safe enough this way," Hawk answered.

The sergeant looked at Barry's clock.

"Nine already, Ed, we gotta be gettin' back on th' job before—"

He jumped, as did the others, for a sudden uproar had sounded from the Communications section. Excited voices rose, and in a moment Colonel Manning tore by on the way to Lunt's office.

"What's the matter?" cried Barry.

"Washington's being bombed! Message Center flashed word—"

Lunt's door burst open. The general came out wild-eyed.

"You're crazy! The Japs couldn't have got around there!"

Captain Barry suddenly turned white. "Good God!" he said. "It's been three weeks since their fleet sailed. If they steamed at full speed, they could have got around the Horn and up into the Atlantic—"

General Lunt snatched up the phone on Barry's desk.

"Get Washington on direct wire," he snarled.

"No use, sir," Manning cut in hoarsely. "Everything's gone dead."

"Impossible! We've a dozen wires—"

"They all went out at the same time. So did all the Message Center stations at Washington. It must have been planned to keep us from knowing about the attack."

Lunt's heavy face had turned the color of paste.

"If they've really got around there,

our only chance is to rush the whole air force across the continent. But we've got to get positive word from Washington before we move. Try the commercial stations, the amateurs—"

"They've been ordered off the air. But I'll try." The Army man dashed down the corridor.

Barry shook his head hopelessly.

"The air will be a mess in five minutes, general. They'll all come on—jump their wave-lengths to try to reach us—and even if we do unscramble them, whom are we going to believe? Spies may report an attack when there isn't any. That first alarm may have been faked—"

Lunt snatched up the phone again. "Get G.H.Q. at the Presidio," he ordered. "They'll have to decide it," he snapped at Barry. "Meantime, go see if Western Union or Postal can get through to Washington."

THE Presidio call came through. The general retired to his office for a private conversation with the Army and Navy seniors. Barry returned a moment later, with word that both commercial telegraph and telephone lines to Washington were dead.

"One radio 'ham' on the edge of Washington confirmed the bombing report," the four-striper told Hawk in a worried tone. "Before we could ask for details, that mystery station jammed the air again."

"There's only one thing to do," Hawk said quickly. "It may be hours before you get the straight report, and you won't be sure then. Get me a fast ship and I'll dash for Washington. I'll see what's happened, fly to the nearest city where there's a land wire open, and flash you word on our personal code."

General Lunt had come out while Hawk was speaking.

"The C.O.C. ordered the same thing—only we'll send half a dozen planes, to be sure one gets through."

Barry trotted away to order the ships started. The harbor man named Ed drew a long breath and looked at the sergeant.

"Say, think of them brown devils sneaking clear down around th—"

"You men keep still about this!" rasped General Lunt. "It's bad enough, without having the whole country go wild."

He stopped as two M.P.'s came along the passage, hauling a prisoner with them.

"What's this?" he grated.

"We got orders to bring this bird down an' turn him over to Captain Barry," said one of the M.P.'s.

Hawk started as he saw the prisoner's glaring face. It was the spy from the *Macon*. He explained to General Lunt. A savage gleam shot into Lunt's eyes. "Spy, eh? By God, now we'll learn something!"

He dismissed the M.P.'s, gruffly told the harbor police to leave. Slamming the door, he stalked across to where the prisoner stood.

"Speak up! Where's the Japanese feet?"

The spy was as pale as death. He

looked at the general with glassy eyes, made no answer. Lunt drew back his fist.

"What this!" he rasped at Hawk. "I'll show you how to make a spy talk."

The smack echoed through the concrete room. Blood spurted from the man's bruised lips.

"Now will you talk?" snarled Lunt.

The spy did not answer. Lunt struck again, and the man jerked back rigidly, stood trembling from head to foot. A startled look came into Hawk's face. He stared at the spy's glassy eyes, and suddenly a chill understanding raced through his brain. He sprang toward the door, jumped aside as he saw the knob turn.

The door swung open and hid him. He heard the gruff voice of the police-boat sergeant.

"Sorry, general—I was lookin' for—"

The door swished shut as Hawk leaped. He saw a blackjack flash down toward Lunt's head. His arm snaked out, cracked fiercely on the sergeant's flexed biceps. The blackjack glanced sidewise along Lunt's head. The general staggered back and fell. Hawk's fingers shot to the butt of the gun in the sergeant's holster. He ducked a vicious blow, jammed the gun into the other man's ribs.

"Get back, or I'll let you have it!"

Cold ferocity shone in the man's eyes as he let the blackjack fall. Before the look on Hawk's face he backed slowly away, raising his hands. Hawk nodded grimly.

"Right. All I ask is a good excuse to shoot."

"I should have killed you out there in the bay," said the other. His voice was low, but it held a murderous note.

Hawk gazed at the seamed and wrinkled face before him. He nodded grudgingly.

"Excellent make-up, but I was a fool not to guess. The motorboat was a decoy to give you time to get onto the police-boat."

Khiro smiled coldly through the leathery make-up which hid his true features.

"If the rest of the 'K' men aren't any better at recognizing me, I needn't worry."

Hawk scowled at the spy-master's effrontery.

"After tomorrow morning, you won't be worrying over anything. Trying to kill Lunt is enough to give you the limit, under martial law, even if I can't get this hypnotized agent of yours to talk later."

"Sorry to disappoint you." Khiro had recovered his poise. His hate, and any fear he felt, were hidden, and his voice was almost indifferent. "I came here as a step in an important plan. You caused me a delay and some trouble, but the end will be the same. Having learned what I wished, I shall be out of here in three minutes—and you, my friend, will be dead."

The man's sheer nerve roused anger in Hawk, but he quickly repressed it. Every word, he knew, was calculated to irritate him and throw him off guard for some sudden move.

Lunt was groaning, his eyes now open. He slowly staggered to his feet, looked dazedly from Hawk to Khiro.

"What the devil—" he began hoarsely. Then he saw the fallen blackjack. With rage-born strength he snatched it up and leaped at the spy master.

"Get back!" shouted Hawk, but it was too late. As Lunt leaped between him and the spy, Khiro whipped one hand down toward his coat. There was a *plop* and a tinkle of shattering glass. Instantly, choking, dense black smoke billowed about Lunt and the spy, and swiftly filled the room.

Lunt's voice sounded thickly from the blackness. Hawk had sprung to one side the moment Lunt blocked his aim. He heard Khiro shout something in a foreign tongue. Some one plunged past him toward the door.

"General!" he yelled, jumping aside as he gave the cry. He heard Lunt gasp from the other direction. The door was swinging open. He fired low, heard the thud of a falling body, then a muffled groan.

CHOKING, breathless, he made his way toward the entrance. Some one brushed against him. He threw himself back. Something whizzed past him, and metal rasped on the concrete wall. Then from out in the smoke-filled passage came shouts of alarm.

"Fire!" a frantic voice yelled.

"It can't be fire down here," another voice shouted. Then, wildly, "Good Lord—maybe it's poison gas!"

Hawk was down on his hands and knees, crawling toward the entry. He heard some one running away from the door. A moment later he heard the general's gasping voice close behind him. He reached back his hand.

"This way," he managed to get out between spasms of coughing.

Lunt made the doorway, collapsed. Hawk put his head close to the floor, managed to get a little fresher air, then dragged the general up the passage. In a few seconds, the smoke began to thin, and soon he saw a corridor light. He hauled the general into clear air, drew a huge breath into his tortured lungs. There was a roaring in his ears, and he could hardly see, but in a moment he began to recover.

Uniformed men gathered hastily about him and the general. Colonel Manning suddenly shoved through the group. Hawk clutched at him.

"Khiro!" he gasped out. "Made up as police sergeant. Try to head him off—" He broke off, coughing.

Manning, after a startled oath, ran for the nearest stairs. Several officers carried Lunt into one of the rooms. Some one tugged at Hawk's sleeve, held out a flask.

"Here—take a shot."

Hawk recognized Barry's aid. He shook his head.

"Rather have water, after that smoke."

The man led him to a water-cooler. Hawk gulped down a drink, turned and pointed along the passage.

"When that smoke clears, you'll find somebody on the floor, probably dead."

I think it's that bird from the *Macon*."

He went up the spiral stairs, was almost at the top when from up on the field he heard the roar of an engine suddenly opened to full speed. Galvanized into action, he ran up and out toward the line. A pistol barked twice, and he saw a man run after a fast-taxiing P-26, firing as he ran.

The speedy little monoplane zoomed, hurtled into a vertical bank not forty feet in the air. Guns snarled from the cowl and down in the landing-gear. The man with the pistol dropped, screaming. A searchlight whipped toward the plane, but the pilot kicked away.

Men were running frantically toward the massed planes as Hawk reached the line. He shot a frantic look around. Not a single Army ship had its engine running. The only plane available was a converted Douglas air liner, which had been equipped as an armed transport and emergency bomber. It stood in the loading zone, engines idling.

He reached the Douglas one jump ahead of an Army lieutenant and a Navy C.P.O. He flashed a keen look at their faces, determined not to be tricked by disguise again. They looked all right. He leaped into the cabin, saw two swiveled Lewises.

"Get on those guns!" he shouted. "I'll take her off—"

"Hey, you guys!" howled a voice from forward. "This is a Staff ship. I got orders to ferry a colonel to Crissy—"

He got no farther. Hawk scrambled up into the pilots' compartment, seized one set of dual controls. The throttles swept forward at his touch. The pilot clawed at Hawk's hand, tried to close the throttles. Hawk stiff-armed him into the other corner, hurled the giant ship out for a fast take-off.

"Wait'll we get on the ground!" yelled the Army man. "No damn Navy bum is goin' to—" He relaxed sourly, seeing the danger of interference at that critical moment.

The Douglas thundered into the air, the roar of its engine muffled within the cabin. Hawk banked as he saw searchlights converge on the fleeing P-26. The little monoplane fighter whirled out of the beams, but the men in the transport's cabin had already opened a hot fire.

"Holy cats!" howled the man beside Hawk. "That's an Army ship. Those guys must be nuts!"

He jumped up to dash back into the cabin. Hawk intervened swiftly.

"There's a dangerous spy in that Boeing!"

"Yeah? How do I know you birds aren't—look out!"

The Army man was up on his toes, shouting. The P-26 had snapped around, its four guns flaming. At terrific speed, the two ships rushed toward each other. Tracers smoked past the transport's huge wing; then Hawk kicked the monster off in a shrieking slip. For a second, the fighter was thrown into range of the starboard gun.

He waited tensely, but no burst hammered from the Lewis behind him. He jerked around angrily.

"Snap into it, you—" The words froze on his lips. Both the Army lieutenant and the C.P.O. were stretched upon the cabin floor. And standing straight behind him, clad in four-striper's garb, was Khiro!

CHAPTER V

BEHIND THE MASK

GRIPPED in the spy master's left hand was a small pistol. His face was still a darker hue than was his natural color, but a hasty touch-up had erased the seamed and wrinkled appearance. The eyes of the Eurasian never left Hawk's face.

"Give the controls to the other man," he said in a passionless voice. Then, as the Army man spun around, gaping, he ordered, "Fly after that Boeing. Keep your eyes to the front."

The Army pilot cursed him, then saw the inert forms in the cabin. Lips working soundlessly, he took the wheel before him.

Hawk felt a sudden lethargy steal over him. He fought against it savagely. Once before, Khiro had brought him under his hypnotic spell, but he had broken it at the last. If he gave in now . . .

His eyes flickered. In the same moment inspiration came. If Khiro thought he had won . . .

He blinked hard, let his eyes shut under that weirdly powerful gaze. The next second they flew open and he sprang with tigerish speed.

The air-pistol gave a low, venomous hiss. A bullet tore through the glass bay of the pilots' compartment. Hawk had plunged low, trying to drive the spy over backward. But in that split second, Khiro twisted around and Hawk dived headlong into the cabin.

Desperately he leaped to his feet. As he whirled, he saw the spy master's hand sweep down, set taut for a blow he knew. Before he could jerk his head aside, that rigid hand crashed at the side of his neck. Strength ebbed from Hawk's veins, but he made a last heroic attempt to seize the pneumatic gun.

Again Khiro's hand flashed down. This time it hit squarely at the back of Hawk's neck. His legs seemed to turn into putty. Lights danced in his brain, but from his head down he had no feeling at all. For a second the plane spun around him dizzily. Then he dropped and the lights ceased to dance.

When he opened his eyes he was dazed to find daylight shining through the cabin windows. He was lying on the floor, his feet toward the tail, his head twisted to one side. For several moments his thoughts were dazed; then he remembered what had happened. His muscles seemed numb, and as he recalled the jiu jitsu blow Khiro had dealt him, a horrible fear surged through him.

Dealt with enough force, that blow could paralyze a man for life! He had known of one such case, where all sensation was gone from the victim's body,

leaving only the brain alive. He tried to move his hand. Cold perspiration broke out on him as it remained motionless. Then slowly he felt returning sensation. As though a million tiny needles were pricking his flesh, feeling began to return to his body.

He drew a long sigh of relief. He was still numb, but it was not paralysis. In a little while it would pass.

His eyes narrowed as they fell on something lying under one of the seats. Khiro's poison dagger! It had slipped from the spy's kit, which lay on the seat above, unrolled. It was not more than fifteen inches from his hand. If he could reach it. . . .

Where was Khiro?

The question put him swiftly on his guard. He rolled his eyes to right and left, but could see nothing of the Eurasian. Was the spy behind him? Was that dagger put there as a trap—to test him?

His eyes lifted to the face of a clock at the rear of the cabin. Something had caused a moving reflection on the glass face. Then he knew. Khiro was behind him, waiting to see what he would do. The implication of that trap brought a sudden hope to Hawk's breast. Khiro did not know whether he was paralyzed. He wanted to make sure.

Slowly, as though by a mighty effort, Hawk moved his head a fraction of an inch. With a muffled groan, he let himself sag. A minute passed. He moved his head again, so that he looked straight at the dagger. Slowly, he let his body stiffen, then after another minute he let his fingers twitch as in a desperate attempt to slide them toward the blade.

Twice, he repeated the grim pretense, till his still half-numbed body ached with the strain of that tension. At last, with a groan of despair, he gave up.

FIVE minutes dragged by. Then Khiro stepped over him and stood looking down at his sweat-bathed face. The spy master had removed all trace of the make-up he had used. By contrast, his naturally pale ivory skin had a sickly hue. His dark eyes, as he gazed down at Hawk, were inscrutable as the Sphinx, seeming almost to look through him and far into space. Yet Hawk knew that the man's cunning brain was measuring him keenly.

At last, Khiro's thin, ascetic lips parted in a mirthless smile. He laughed, and the sound sent a shiver through Hawk, though he hid his feeling.

"And so the mighty Hawk has fallen," Khiro said mockingly. His voice was cool, precise, his English perfect. It was hard to believe, even now, that his voice had spoken the rough barbarisms of the harbor-police sergeant.

Hawk moved his lips, made a hoarse sound. Khiro shook his head.

"Don't trouble yourself; I can guess what your comments would be—if you could speak." He stooped and picked up the dagger. "Perhaps you wonder why I do not finish you and toss you into the sea, as I did those two others."

Hawk gave no sign, but his pulses leaped. They were over the ocean. . . .

Which ocean? Where were they?

He had trouble hiding his emotion at that thought. They could have crossed the continent—or they might be far out in the Pacific!

"I shall keep you alive until your voice comes back," Khiro was saying suavely. "You have certain information about your Secret Service which I could use, after we have forced your country to surrender."

Hawk's eyes flashed in spite of him. Khiro's lips curled again in their cold, thin smile.

"I am the one who should feel animosity, my friend. In your blundering way, you nearly upset my careful schemes. However, you made amends by helping me escape after I borrowed Captain Barry's uniform coat. It will always be a pleasant memory—that moment when you turned and saw me in the cabin. I should like a portrait of you, with that stunned expression."

Hawk met his eyes stoically. It was all clear now. The entire crew of the police boat had been Khiro's spies. The boat had probably been seized earlier in the evening and the real crew killed. The spy crew had come ashore on the Oakland field, to arrange for Khiro's escape in an emergency, after he had learned what he wanted.

The pilot of the P-26 had been one of the Eurasian's agents, and undoubtedly the order causing the Douglas to be started had been a false one. Hawk's thought shifted to the Army pilot. The Douglas must have been landed for fuel somewhere—it was now 4.30 in the afternoon. Did Khiro have some one else at the controls, picked up at a refuelling point, or had he cowed the Army man into following his orders?

A fitting shadow crossed the cabin, and Khiro quickly looked out to the right. Hawk rolled his eyes as far as he could. With sudden dismay he saw three Kawasaki fighters sweep in and form an escort for the Douglas. His plan was instantly blasted. Even if he overcame Khiro by a ruse, those fast Jap hornets could down the air liner in seconds.

Kawasakis! There must be a carrier near, for the speedy little ships had a very short range. Confirmation of this surmise followed shortly. The sound of the motors increased as the door to the pilots' compartment opened. The voice of the Army pilot rose fiercely.

"I can't land this crate on that deck! I never landed on a carrier in my life!"

"Perhaps with your life at stake—" Khiro's voice had a grim significance. He calmly stepped over Hawk and went forward.

The roar of the motors died, and Hawk felt the big ship start into a slow spiral. Instinct bade him jump to his feet, rush Khiro, trust to the plane's high speed for an escape. Reason forced him to lie motionless. The Kawasakis could make 205. Chances of escape were one in a thousand. This way, he had a chance to learn the Japanese plans. . . .

The Douglas lost speed. He felt the wheels hit solidly. The engines roared full on. The Army man went up for an-

other try. The third attempt was a success. Hawk felt the wheel-brakes go on hastily. The huge air liner slowed, trembled to a stop. The engines died.

Khiro came back swiftly, bent over the make-up kit. When the cabin door opened, a moment later, the red silk mask hid his face. Only his black, piercing eyes remained visible.

AS Hawk lay tensely waiting, a short, stocky Japanese naval officer entered the cabin, followed by four men with rifles. His dark eyes probed around quickly, rested on Hawk, changed expression at sight of Khiro's red mask. He saluted formally, spoke in Japanese.

"My ship is honored to receive the chosen adviser to the Empire."

Khiro made a peculiar sign, swiftly moving both hands.

"To the Rising Sun—may its light spread," he intoned with a hint of impatience. "I shall permit you to identify my face in private," he added. "You understand my custom."

The Japanese bowed. "It is understood. But these two—" He motioned toward Hawk and the Army pilot, who had come out of the pilots' compartment. "Is there further need for them?"

"The pilot, perhaps," said Khiro. "This is a new and fast plane. Keep him a prisoner for the time. As for this other, he is paralyzed." He made a motion showing how he had struck Hawk.

The Japanese chuckled. Khiro laughed thinly.

"You have a nice sense of humor, Captain Mituri. Later, I may give you more to laugh at, in connection with this man. Just now, I want him also locked up below—but he had better be carried on a stretcher."

Mituri gave an order. Two grim-faced Jap soldiers roughly took the Army pilot outside. Hawk heard him cursing them as he was hustled below. The other two Japs went for a stretcher. Mituri looked anxiously at Khiro.

"Does your coming presage any failure in our plans?"

"No, only a change. Washington is not convinced. The entire attack tonight must be against the capital instead of New York. Their last doubt must be removed, so that their President will be forced to call all their planes to defend the Atlantic coast."

"But New York is their greatest city—"

"We will strike there, too—with this Douglas. It will take only a few hours to install the chemical tanks and release device. And tonight it will snow, in New York!"

Mituri grinned. Hawk listened intently as the Japanese asked a question.

"They still do not suspect the truth—there in San Francisco?"

The eyes back of the red mask shifted down to Hawk.

"No, they think it is some kind of invisible ray."

The men returned with the stretcher. Hawk was lifted onto it and carried outside. As he had guessed, he was on the flat deck of a carrier. His eyes roamed about quickly; then amazement

almost overcame him.

He was on the *Mirahota!*

The old carrier had not been sunk at all. There were still signs of damage from fire, but plainly she was in sea-going condition. The whole thing had been a monstrous trick. The old carrier had been spirited out to sea after newsreels had been taken showing her on fire and apparently doomed. Reconditioned, she had taken a cargo of planes and sailed down to the tip of South America and up into the Atlantic. It had been a full month since she had been reported burned. All this time she had been on her way to the east coast of America, preparing for this trick.

Hawk's mind was still seething when the Japs deposited him on the floor of the brig. For a moment, after the brown soldiers had departed and locked the door, he did not see the Army pilot squatting glumly on a broken-down bunk in the corner.

"Well, this is sure a helluva mess," the Army man said lugubriously. He had a homely, freckled face, which just now was a dismal picture. "At that, I oughta be glad I ain't laid out like you."

Hawk measured him carefully. He would need this man's help. He had to trust him with the truth. With a guarded look at the grilled opening, he slowly winked. The other man's eyes widened.

"Holy cats! You mean—"

"Not so loud," muttered Hawk.

The other man got up, peered out through the grill. "Okay," he said, in a low voice. "Say, would you mind tellin' me what the hell this is all about?"

Hawk sketched the situation briefly. The Army man, who gave his name as Pete O'Reilly, filled in the space during which Hawk had been unconscious.

"He held a gun on me, made me land twice and fuel. Had men he knew waitin' for him. One of 'em came to the last field—emergency spot near Baltimore. We've been headin' over water a good two hours."

"This is the only vessel you saw?"

"Yeah, except for a couple of subs scoutin' a little ahead of her."

"Then I was right. This is the only ship they've got in the Atlantic. The subs were sent to take care of any vessel that might get too close."

"At that, I can't dope how they got clear up here without bein' spotted," said Pete.

"Probably had planes flying high, directing her away from everything. It's a clever scheme. Tonight's attack on Washington and New York will convince the Brass Hats. The East Coast will go wild, and the President will be forced to order defense planes east, and at least part of the Fleet to rush for the Canal."

"And then the Japs will catch the Pacific coast flat-footed!" groaned Pete. Hawk nodded grimly.

"With their full fleet, they'll be able to beat through whatever force is left. They'll bomb the big coast cities and pound them with long-range guns. And it's a hundred to one they've got some plan for closing the Canal so the rest of the Fleet can't get back. It's a cold-

stacked deck. Rather than let the West Coast be ravaged, the President will probably take the devils' terms—give up our Far East policy—Hawaii, the Philippines—”

“And we've got to stick in here and let 'em get away with it!” raged the Army man.

Hawk was glumly silent. In a short time, the sky darkened. There was no light in the cramped, chilly brig. After a while, he stood up and began to pace to keep warm, keeping his ears open for sounds from outside. Time seemed to drag interminably. Cold, hungry and miserable, he and Pete waited through long hours.

CHAPTER VI

RAIN OF DEATH

IT was about ten o'clock, he estimated, when the vessel's engines slowed. A little later a plane roared down and signaled for deck-lights. Its arrival seemed the signal for feverish activity. Soon plane engines began to rumble, up on the deck. Hawk paced the narrow cage, fuming at his helplessness.

“Twin-motored bombers, by the sound of 'em,” Pete muttered from the gloom. “It won't be long now.”

Soon afterward, a booming roar heralded the take-off of the first Jap plane. For several minutes the air was filled with steady thunder. Then it lessened. Hawk was cursing himself for not having taken the long chance in the Douglas, when a light from outside flicked toward the grill of the iron door.

He threw himself down on the stretcher. The light probed in through the grill; then the lock clicked, and two Jap sentries appeared, bayoneted rifles held ready.

“Turn on the light,” a curt voice ordered in Japanese.

Hawk's muscles went taut. It was Khiro!

One of the Japs went down the passage and switched on the light. Khiro stepped inside, garbed in helmet, flying-coat and gloves. The red mask still hid his features. From under his brown leather coat showed the blue trousers which had served him in the rôle of both police-sergeant and naval officer.

The spy-master gave a sharp glance at Hawk, then motioned to the Army pilot. “Come, I have use for you,” he said.

“How'd you like to go to hell!” snarled Pete.

Khiro pivoted toward the Japs.

“Take him above. Be careful not to injure him. He is to fly the big plane for us.”

The words were in Japanese, but Pete seemed to guess their meaning. He swung savagely on the first soldier. Khiro's gloved hand flashed out, twisted the Army man's wrist. Pete plunged to his knees, groaning. The two Japs dragged him out of the cell, hauled him to his feet. Khiro looked down sardonically at Hawk.

“I regret that our tête-à-tête must wait. It is necessary for me to go to Washington, to follow up tonight's busi-

ness, but I shall be looking forward to the pleasure of—”

Outside, there was a sudden explosion of Japanese oaths. Hawk heard Pete's angry voice rise above the others, caught the smack of a fist against flesh. Khiro's glance shifted. He took a step to see what had happened.

Hawk's feet came up like catapults. He drove them fiercely into the spy-master's solar plexus. A tortured gasp was wrenched from Khiro's throat. Hawk was on his feet before the spy had slumped to the iron deck-plates. He seized Khiro's helmet, snatched the red mask. He put them on quickly. To roll the spy-master out of the flying-coat was the work of seconds. He had donned the coat and was pulling on Khiro's gloves when the commotion in the passage abruptly ceased.

He spun around, blocked the door as the two Japs appeared, their uniform caps awry, their faces bearing marks of conflict. They had dropped their rifles, were holding Pete's arms twisted behind him. As Hawk came out, one of the men gave Pete a vengeful kick.

“I said he was not to be harmed!” Hawk rasped in Japanese.

“But the American dog—” began one Jap.

“Enough!” snapped Hawk. The Nipponese quailed before his glare. “Are you weaklings, that two of you cannot handle one unarmed man?”

The sentries did not answer. Hawk saw other Japs staring from the adjacent compartment. He made an imperative gesture.

“March him up on deck,” he ordered.

One of the men started to move toward the brig door, hauling Pete with him so that he could reach the key in the lock.

“I will take care of that,” said Hawk. He motioned the men ahead. They started on, but others of the crew were watching from both ends of the passage. There was no chance to bind and gag Khiro, as he had intended. He closed the door, locked it, and quickly followed Pete and his captors, praying that Khiro would not recover from that blow for several minutes.

As they reached the flying-deck, Hawk made a hasty survey. The *Mirahota* was steaming into the wind. The Douglas was lined up for taking-off, its engines running. A Mitsubishi two-seater reconnaissance ship stood at one side, and near it were three Kawasaki fighters, lined up apparently for alert duty. Only one other ship was on the flying-deck—a U. S. Navy Corsair. Near the Corsair, a man in flying-suit was talking with Mituri, the *Mirahota's* commander.

The Jap commander came forward quickly. He looked at Pete as the Army man struggled with his guards, then pivoted with a sharp glance at Hawk.

“I thought, your Excellency, this man was to be fully under your control by now.”

Hawk hid a start. So Khiro had intended to hypnotize Pete!

“I had him brought up here to save time. Give me a moment with him, and he will be like putty in my hands.”

He snapped an order at the two Jap guards. Pete was shoved against the superstructure at the side of the flying-deck. Hawk followed quickly, glared through his eye-slits at the Army man.

“Don't let on,” he rapped in English. “This isn't Khiro—”

“Holy cats—” Pete burst out.

“Silence!” rasped Hawk, aware that Mituri was almost in earshot. “Act as though you're hypnotized. Then do what I tell you.”

“Got it,” Pete said in a muffled tone. His eyes took on a blank look which at another time would have been comical.

“You will fly the Douglas plane as I direct,” Hawk went on in a tone of heavy menace. “We will take off at once.” He turned, pointed toward the big ship. “Release him,” he snapped at the Jap soldiers, in their own tongue. “He is completely in my power.”

The Nipponese, with an awed look at Hawk's red mask, did as he ordered. But halfway to the Douglas, Mituri interposed an anxious protest.

“If you have to go with him, what of our plans in Washington? Your agent is ready with the Corsair—”

“He is to go without me,” Hawk cut in abruptly. “I will join him later.”

“But the false aerial photographs! You were to show their President that our whole fleet—” Mituri's dark eyes suddenly changed.

“You are not Khiro!” he shouted.

HAWK had whirled as he read the look in Mituri's eyes. He snatched a rifle from the nearest sentry. The second man gave a cry, and lunged. Hawk clubbed him down without stopping in his swing. The Corsair pilot clutched a gun on his hip. Pete O'Reilly launched himself with a tigerish spring. The agent went down in a heap. Pete seized the pistol, and drilled the first sentry, who was diving in furiously.

“The ship!” shouted Hawk.

Mituri had jumped back, was screaming wildly for help. Pilots on the alert detail came dashing toward the spot. A brown-faced mechanic seized a heavy wrench, hurled it at Hawk's head.

Hawk ducked, shot down a Nipponese with a drawn automatic. Back of him he heard two shots, then a yell from Pete. He spun around, sprinted for the plane. A dozen mechanics charged across the deck. He swung the rifle like a club, felt it thud against one man's skull, saw the others give back.

Bullets thudded into the side of the cabin as he reached the door. He slammed the rifle into the knot of yelling mechanics. As he tumbled inside, he saw Pete fighting madly with a Nippon pilot who had been in the cabin.

A horde of screeching Japs was almost at the side of the Douglas. Hawk leaped to a dangling Lewis, spun it on its swivel. The charging handle raked back; then a murderous stream blazed into the howling mob. Infuriated brown faces turned into welters of blood. A score of Japs went down. Others sprang over the fallen bodies of their comrades. Hawk held the trigger down, saw the second group melt under a deadly blast.

Only one man remained in the mob which had charged the cabin. Like a madman, the Jap leaped for the spouting gun. His hands were almost on the smoking muzzle when Hawk twitched the gun around. He winced as he saw the bullets tear into the doomed man's face.

Dropping the Lewis, he jumped to Pete's side. The Army man had forced his opponent backward over one of two tanks which had been installed in the cabin. There was a crack, a scream, and the Japanese fell to the floor. Hawk sprang for the pilot's compartment. A machine gun raged on deck as he reached the controls. A new force of attackers had been rushed up from the lower decks. A second machine gun hammered lead into the cabin as he pushed the throttles open.

The floodlights had sprung up in full glare. As the Douglas plunged forward, Hawk saw a blue-clad figure run from one side of the superstructure. Gold stripes shone on the man's sleeve. Hawk swore as he recognized Khiro.

The spy-master was running toward one of the Kawasakis. A Jap pilot vaulted into the first ship, and a mechanic hastily wound the starter. As the Douglas raced down the long flying-deck, Hawk saw Khiro spring up into the next ship. Then the huge air liner picked up speed, and he jerked his eyes away.

He held his breath as the end of the deck appeared. The Douglas roared off into space, dropped toward the sea. With a fervent prayer, he pulled the wheel back. The hungry waves clutched at the landing gear; then slowly the air liner lifted. Hawk let it gain speed, then pulled up into a climb. An ominous pounding told him that the ship was under fire. He kicked around sharply as tracers gouged the left wing. Back in the cabin, Pete gave a howl.

"Hang on!" shouted Hawk. He rolled the wheel, and the air liner's huge wing whipped down in a vertical bank.

Straight underneath, zooming for the blind spot, was the Jap fighter. As Pete cut loose with the Lewis, four fuzzy red lines stabbed from the Kawasaki's nose. The Douglas quivered. Glass ripped from the cabin windows. Then suddenly the four red lines were gone. Pete gave another howl, this one of joy. The Jap ship skidded, rolled over and sprang ablaze.

Hawk hurled the Douglas westward. Archie and machine guns were going mad, down on the carrier. He flew through a storm of shrapnel and bullets, tensely expecting to hear a prop let go at any moment. But gradually the hail of steel diminished. He looked around hastily, but saw nothing of Khiro's ship. Behind, searchlights were combing the sky, too far away to be of harm now.

He turned quickly in his seat as Pete came forward. Giving the Army man the controls, he took off the red mask and bent over a map clipped before him. A circle showed the *Mirahota's* position. He felt his heart sink as he saw how close it was to the coast. A dotted red line ran from the circle to New York. That was the course they had intended

the Douglas to take. But those bombers—they were racing straight in for Washington, with a lead of twenty minutes . . .

His eyes met Pete's. The Army man's freckled face was white in the dim glow from the instrument board light. He changed the adjustable pitch propellers, watched the airspeed meter.

"Something rotten in Denmark," he muttered. "They must have put some bum gas in the tanks."

"Do your best," Hawk said grimly. He crawled out of his seat, went back into the cabin. When he returned, ten minutes later, his eyes had a queer, hard

the Jap bombing squadron!

"Climb!" he rasped at Pete. As the Douglas howled skyward, he cut off the compartment light. Ships came into view ahead and below—K-37's, as he had expected. They were racing with wide open engines. The big Douglas was barely gaining on them as it climbed, for the Japs were leveled out.

They were in a wide V formation. As Hawk stared down, he saw the lead ship swing slightly south. Pete started to follow.

"No! Keep straight ahead!" grated Hawk. "It's our only chance."

The Japs were heading for the Potomac. They would hit Bolling Field and Naval Air first. The fields were empty, their planes shifted to the Pacific, but they afforded guiding points to the capital.

Searchlights were swinging frenziedly toward the Jap bombers. Hawk's straining eyes flashed down to the toggle-and-spring device from which a flexible cable ran back into the cabin. His hand dropped toward the knob. If he only knew the full secret of that . . .

Crash! A blast of slugs tore through the roof of the pilots' compartment, ripped out through the nose. Pete cried out, slid forward over his wheel. Hawk caught him, pulled him back in the seat. Pete was clawing at his right side, his fingers stained red. Another vicious burst crashed back into the cabin. Hawk seized the dual controls, flung the Douglas into a steep chandelle.

With a deafening roar, a fighter pitched from the night. Hawk snarled as he saw a Kawasaki. Khiro, plunging in at the last to save his bloody scheme!

The Jap ship curled in, shrieking. Four scarlet eyes flamed. Hawk kicked away. The smoking torrent passed over the rounded roof, battered into the wing. With sudden, black rage, Hawk hurled the Douglas straight at the Kawasaki.

A patriot Jap might give his life to crash a foe from the sky. But Khiro was no Jap!

One mad instant the two ships dashed headlong. The spy-master's guns frantically belched their red death. The liner's rounded bow crumpled. Bullets gashed back through the instrument panel. A slug ripped at Hawk's helmet, and blood oozed out as hot lead grazed his thigh.

Then Khiro dived wildly down the sky.

Hawk threw the big ship around as though it had been a fighter. Eyes slitted against the wind which howled through the roof, he raced down toward the Potomac.

The Japs were spreading in a wide arc. Hawk shoved the wheel forward. The Douglas thundered into the path of the charging Nipponese. He saw a signal rocket flare from Khiro's diving ship. Then his hand pulled the toggle-release.

For a second he thought he had failed. With a roar, the nearest bow gunner cut loose with his Q.F. guns. He felt the control pedals jump. Then abruptly the battering ceased.

He stared back, holding the Douglas to its diagonal plunge in front of the

Winners of Missing Words Contest No. 7

First Prize—RICHARD S. BISBEY, 784 Market Street, Meadville, Pa. *Second Prize*—CYRIL A. BISTYAK, 4826 So. Damen Ave., Chicago, Ill. *And Three Prizes*—LLOYD LEWIS, 177 So. Ogden Street, Denver, Col., FRED WOODARD, 60A Nassau Street, Toronto, Ontario, Canada, and D. HAROLD MCLEOD, 1622 14th Avenue, Columbus, Georgia.

This contest appeared in the November issue of FLYING ACES

look. He gazed ahead, saw dots of light along the coast.

The southern tip of New Jersey swept past on their right. The ship roared above Cape Henlopen, thundered straight west toward the Chesapeake. As they raced above Eastern Bay, Hawk switched on the radio. With the mike at his lips, he hesitated, staring into space.

If he warned the capital, panic would follow. It would not stop that rain of death from the skies. It might increase the victims a hundred-fold. The streets would be filled with people frantically trying to escape into open country . . .

"Look!" yelled Pete.

Long fingers of light were sweeping skyward, on the western side of Chesapeake. The Douglas roared on at more than three miles a minute. The lights grew brighter, and suddenly Hawk saw fitting shapes plunge through the beams, headed west.

"It's Annapolis!" Pete said tensely. "They've spotted those rats!"

Annapolis! Less than ten minutes to Washington at their speed—but the Japs were still ahead!

ABRUPTLY, it seemed to Hawk's wire-tight nerves, the capital was ablaze with a score of searchlights. He groaned. Archie would have small chance against that horde. Better to have kept the city dark.

He jumped erect. Not three hundred yards ahead was the rearmost ship of

Japanese squadron. A purplish vapor was billowing from the air liner's tail. Half of the Junkers ships were already hidden from sight. The rest were whirling madly at sight of that purple cloud.

Two Japs brushed wings in the frantic attempt to escape. The two ships lurched, collided with a roar. Down they went, a solid mass of flame.

Suddenly a bright violet light flashed up to the rear of the Douglas. Hawk gazed back, started. The purple vapor had faded, but in its place were flakes that looked like snow. One of the frightened Japs flew into the falling flakes. There was an explosion, and purple fire swept over the bomber's nose.

Hawk watched the trapped pilots as they vainly tried to flee. The last of the explosive nitrogen chloride had frozen into flakes. They fell slowly, like

snow—but a strange and terrible snow. There came a flash, and again and again those flakes blazed purple death.

A picture came before Hawk's eyes—a pilot falling in a chute, a hand raised to brush away those innocent-seeming flakes . . . a flash, and a headless body falling . . .

Slowly, he swung the big ship toward the ground. There was no sign of Khiro's ship, but he knew that the spy still lived. He had zoomed at first sign of that deadly purple cloud.

For the time, the Japs had failed. Their fleet in the west would withdraw. The *Mirahota* crew would take to the subs or die with their scuttled ship. The bombers were even now being blown to bits as they crashed. No war guilt could be proved, for Khiro had planned too well.

The Decoy Duel

(Continued from page 24)

"Seems like a good egg," approved McCraig, rising to his feet. "A little soft, perhaps."

"Whenever you think of Garth, lieutenant," reminded the squadron commander, "think of steel encased in velvet."

"I'll remember," said the airman.

McCRAIG left the office and sauntered outside, his mind centered on one thing—the mysterious girl across the lines.

Slow hours passed, and time dragged heavily. It was always that way when McCraig had nothing to do. There was a big binge on at the White Horse Cafe in Brencourt to celebrate the nineteenth birthday of one of his flight comrades, but Joe passed it up, along with a poker game.

He felt too restless, unsettled to play. Wherever he looked, he saw the dark, sad eyes of a girl dressed in the rough garb of a peasant boy. Why was she there, risking her life, and what was Q-19 to her? And why hadn't he explained to Garth that he hadn't made contact with Q-19 in person? He didn't know.

Thoughtfully he loosened the strings of a tobacco sack, and rolled a cigarette. Smoke curled in thin clouds before his eyes. He leaned against the wall of the building close to the door leading to the field. Idly he watched the other pilots.

Often McCraig watched others, almost able to see their hearts hammering against their tunics. He could sense the tightening forces that gripped and squeezed. He knew their thoughts. His were the same. He felt as they felt. Only he covered all trace of the fear and pretended, while these other pilots watched him, that he wasn't afraid.

He laughed and kidded them now as they filed out into the night to a short-lived gaiety. The building quieted down. Candles spluttered. Night wore on. Everything was as it always was except . . .

There was a trembling beneath the foundations of the building like a minor earthquake. It was a rippling, crawling shock that set things to rocking. Joe stared at his dusty boots, at the floor beneath them. His body swayed. He frowned, spun on his heel and jumped out the door to the darkened field.

There was a red smear of flame arching into the sky far to the west, where the backroads of war converged in a great railroad center. An ammunition dump was climbing into the sky, its explosions dulling the throb of engines powering giant Gothas.

Joe stared and wondered. After a long time, he returned to his bunk and surrendered himself to sleep. And while he slept, another man kept vigil through the night—the ponderous, heavy-jowled Garth.

AT the end of a wooden barracks building, cluttered with a maze of wireless transmitting and receiving sets, telephones and topographical maps, Captain Garth of G-2 kept his fingers on the pulse of his scattered band of fearless operators who risked their lives hourly in the endless quest for information.

The Intelligence officer had a decoded message before him. He stared at it with puzzled eyes. Not a word about the concentration of aircraft, he was thinking. Nothing but the threat against the ammunition dump at Bois de Veray. What was the answer? Had Q-19 got himself into a jam?

The telephone buzzed. Garth jerked the receiver from the hook and jammed it against his ear. A voice crackled fretfully at the other end of the line. The big man listened with all the patience at his command. He knew this would have to come. Some one would have to shoulder the blame. His voice hardened as he took the jolt.

"Yes, General Wingate. I issued the order. I did so because of certain information placed in my hands early this

Hawk's face was grim and stony. Some day, his path would cross with Khiro's again. When that time came . . .

He shrugged. Let the future wait. Just now he was very tired. He eased the throttles, slanted toward Bolling Field. As the battered ship rolled to a stop, he looked across at Pete. Pete's face was white, and one hand was pressed hard against his side.

"Hurt very much?" Hawk asked anxiously.

"Naw, just a nick." Pete drew a long breath. "Boy, that sure was a damn quick war!" Then after a moment, he looked curiously at Hawk. "Funny, we've been through this fracas and I don't even know your name."

Hawk hesitated, then slowly grinned. "Just call me a Navy bum."

afternoon, and I'll accept full responsibility. Good-night."

He reached for a cigarette, but a second summons arrested his hand. He lifted the receiver and braced himself for a second jolt. One of his operators was calling in from Bois de Vernay. Garth listened quietly until the man had finished with the report.

"Destruction complete, eh? That's tough. It puts me in bad all around. Well, there's nothing further we can do. Find out the names and rank of those men responsible for the lights. G'night."

He half-twisted around to say something to the wireless operator when the operator himself spoke.

"Grab the headphones, sir. Station 3XR of Longuyon coming over."

Garth clamped on the headphones. A droning voice reached his ears. It was punctuated with crackling static, but he recognized the guttural voice of the Longuyon operator.

"Hören Sie!" announced the voice. "Listen. Station operators at Etain, Conflans and Montmedy—" Static crackled like gunfire. The voice resumed. "Keep a strict watch on all highways, railroads and air fields. An *Amerikaner Espion* known as Q-19—"

Static again crashed about their ears. They twisted in their chairs, straining to catch those next few words. The broken period lasted less than sixty seconds. The voice continued.

". . . orders of Air Ministry."

The set went silent. The station at Longuyon had signed off. The completed message had failed to come through. They had heard only a garbled warning, with the most important part missing.

Garth leaned back in his chair, lit a cigarette, and pondered. Mentally he tried to fill in the blank spot, but he could only conjecture, make a wild guess. Either Q-19 was a prisoner, or he had been a prisoner and had escaped. If he had escaped, he'd be in Germany

somewhere, in hiding. He would be waiting for his chief, Garth, to get him out.

But the Intelligence officer wasn't sure, and there was only one way he could find out. That way led to a stone tomb behind a German battery of anti-aircraft guns.

McCraig had reached the spot once. He could reach it again. If this pilot was sent over in the uniform of"

The telephone bell shattered his thoughts. He clamped the receiver to his ear. "Captain Garth? Yes What? A Gotha, eh? One of the bombers. Shot down and reached the ground without a crack-up. Good. Listen. This is important. I want that ship, understand? Put a triple guard around it so that the souvenir hounds won't carry it away in their pockets."

The voice at the other end of the wire told him that these precautions had already been taken.

"Very well," said Garth. "Bring the three German airmen to my headquarters at once."

An observer, a machine gunner, and the pilot of the ill-fated Gotha were brought before him some hours later. He questioned them in hope of finding out what he wanted to know, but the gunner and observer refused to talk. Garth turned to the pilot, a grizzled veteran with a jaw like the prow of a destroyer.

"*Leutnant*, are you tongue-tied, also?"

"*Jawohl, Herr Kapitan*. Just that. I have nothing to say."

Promises and threats were useless. Garth dismissed the trio with a wave of his hand. The officer in charge of the guard lagged behind.

Garth lumbered to his feet. His voice was hardly above a whisper as he spoke into that officer's ear. "Outfit that pilot with denim and bring his uniform, helmet and goggles to this office."

Alone again, he sat down. He was tired, and more than a little worried over the fate of a certain man behind the German lines. His whole system of espionage behind those lines revolved around this one man.

In a military sense, Garth was not bound to protect his operators once they got into trouble. They knew, these adventurers across the enemy lines, that no protection or help could be offered, and they never expected any. They were on their own. It was their duty to supply information. It was their duty to die by the firing squad if they were captured—and die with sealed lips.

But the man known only by the cryptic number Q-19 was no ordinary operator. Garth had planted him behind the enemy lines early in the war. If anything should happen to this man, there would be no way to replace him. Operators were plentiful. One had merely to issue an order. But with Q-19, Garth was prepared to make any sacrifice to shield and protect his ace spy. Yes, Q-19 must be saved, even if Garth had to deliberately nail another man to the cross to accomplish it.

Yet had he the right to frame another man, an officer like Lieutenant McCraig? It was a question that only his conscience could answer. He found

it difficult to make the decision, and he knew that he couldn't let things ride on the off chance that something would intervene, that luck would turn. Many issues were at stake. If he sacrificed one man, he'd save the lives of countless thousands. Garth shivered and felt suddenly cold.

He sat quiet for a long time. The decision was still to be made. In the last analysis, would he dare carry out his plan? Alternately, between answering the phone and smoking innumerable cigarettes, he dozed and awakened. Dark faded. Red dawn moved over the earth.

HAD Joe McCraig known the part that was to be assigned to him in this game of air intrigue, he would have had cause for deep resentment. Blind to the strange fate in store for him, he acknowledged the summons brought to him by an orderly and reported at once to the operations office, where Garth and Major Soule awaited him.

"Sit down, lieutenant," ordered Captain Garth. "The information contained in the document you brought back was false, and not from Q-19. It was a Boche plant."

McCraig's eyes narrowed. "Not from Q-19? Are you sure?"

"Quite. After I had acted on the information you brought in, our biggest ammunition depot in the A.E.F. was blown up. Want to know how it happened?"

Joe suddenly recalled the tremendous explosion of the night before, and the red glow in the sky. He nodded without speaking.

Garth continued. "According to the information decoded from that document you brought to me, this particular ammunition dump was slated for bombing tomorrow night, and the instructions were to move everything regardless of labor and confusion. That meant about ten hours of darkness in which to perform this labor."

He leaned forward in his chair. "Do you see the devilish ingenuity behind the whole thing? Ordinarily, there wouldn't be a light visible within miles of this particular ammunition dump. But with thousands of men and trucks suddenly ordered to shift this huge pile of explosives from one spot to another, it was obviously impossible to overcome the human element of error. And that error," he observed, "was the use of lights to facilitate the handling of the many tons of high explosives."

"But, captain," broke in Major Soule. "Regulations—any officer with common sense—"

"Any way you figure it, major, the answer is the same. With so many enlisted men, so many officers, you'll always find some who know nothing of regulations, and others who don't give a damn. The Germans figured that out. They knew that the ammunition would be moved last night because they knew the contents of that coded document. They knew that there would be certain careless men who would advertise the fact. And they worked on that basis."

He stared for a long moment at the corrugated metal ceiling. "A fleet of Gotha bombers was sent over. Everything below was inky black except the one spot the observers watched for. The winking lights in Bois de Vernay could be seen quite plainly—a dead give-away. Calcium flares were dropped overside. The target lay revealed. It covered considerable territory. They couldn't miss with their bombs."

McCraig stalled for time. The silence around him was thickening. It became accusing. His eyes settled on Garth.

"This is serious, Captain Garth," McCraig said quietly.

"Very."

"Then the person from whom I received the sealed packet—"

"Was an agent working with Germany's Chief of Intelligence, *Herr* Colonel Haeckel at Longuyon," finished Garth, quietly.

Joe felt his throat go dry. There was a tightening of muscles around his heart. He had the feeling that something beautiful was slipping from his fingers, something he'd never recapture.

"Captain Garth," he said levelly, "call this a confession if you care to. It doesn't matter much, now. I offer no excuse for what I have failed to reveal except the blindness of infatuation. The person who gave me the message was a girl."

By not so much as a twitch of an eyelash did the expression on Garth's face change. "A girl, eh? I wish you had mentioned this yesterday. Describe her."

"Short, slender, dressed like a peasant boy with smock, cap and wooden *sabots*. In fact, she looked like a boy. Her hair was cut fairly short, and was black and curly."

"Would you recognize her on sight if you saw her again?"

"I would."

"Very well, lieutenant. I'm sending you out to find her. If she's a friend of Q-19, she'll be waiting at the tomb at the same hour as yesterday. If she isn't there, I'll know that she isn't in touch with my operator. In that case, you will return to this field and consider the affair closed."

He pointed to a blue barracks bag near the door. "In that you'll find a complete German officer's flying outfit. Put it on. I'll furnish you with instructions in code and an identity card which you will present to Q-19 or his agent."

"But why the uniform?" asked the puzzled airman.

"That," observed Garth, "will serve to protect you in case—in case, shall we say, of a forced landing. If you don't get back in a reasonable length of time, we'll know something's happened. Stick as close to the monument as you can."

McCraig was suddenly wary. He couldn't understand why he should wear the gray-green uniform when it wasn't required on the first trip out. He looked for the reason in Garth's face, and saw only a mask of complete serenity.

"If those are your orders," he shrugged, "I'll obey."

He lifted his rangy figure from the chair. "Anything more?" he asked.

"All I require," said Garth, levelly, "is that you make contact with this girl, or whoever else appears. Hand over the instructions I am giving you, and return to this field in the shortest possible time. Those are your orders."

Joe took the barracks bag with its German uniform and went at once to quarters to make the change.

Garth picked up the phone. A member of his organization at Souilly answered. "Start your wireless. Everything's set. His Spad number is S-317. Got it? Good."

The spy trap was set. Its jaws were wide open.

THE hour for the take-off arrived, and was announced by the roar of a motor out on the field. Joe McCraig, dressed in the gray-green uniform of the Imperial Air Service, crossed the tarmac slowly, then climbed into the pit. His eyes turned skyward.

The ceiling had lowered since dawn. The low-hanging clouds were less than a thousand feet up. That was all right, too. It would make his task of evading enemy ships easier.

He examined the instrument panel, checked ammo belts and saw that his fuel indicator showed full. There was nothing else he could do. He felt for the documents Garth had given him. The holster of the .45 Colt rested on his hip. He was ready.

Swift spirals brought him to the ceiling. As far as his eyes ranged, there was nothing but low-lying clouds. Invisible miles slid behind. He kept close watch of compass, speed indicator and his watch. For half an hour his machine droned through wet, reeking clouds.

The altimeter registered fifteen hundred feet. Joe figured he had about reached the Archie battery and was beyond it. He flicked the stick slightly ahead. The nose dropped. Grimly he stared through thinning mists.

Abruptly, with a sickening lurch, the Spad dropped into a treacherous air pocket. Joe grunted, hauling back on the stick. The air became filled with bumps. Shells were exploding with vicious smacks all over the sky. It was strange that though the gunners couldn't see him, they were shooting so damned close.

Action cut short his futile speculation. This was something he understood. He had the Archie battery spotted. It was set down in his mind to the exact yard.

He lifted the Spad in a zooming reach for altitude, leveled off and sent it streaking into the north. The bursting shells were now behind him. He kept them there until he could no longer hear them. And then, with the motor throttled back, he swept the plane into a reversement and cut back southward towards the road in the rear of the battery. Downward it swooped as the pilot built up speed.

At last he spotted the road. There was a gash in the tree tops bordering it, as though gigantic clippers had snipped away their upper branches. The Hissó moaned softly as the plane

banked and settled. There was the road disappearing into the haze at one end, and losing itself into a soft curve of a hill at the other.

McCraig could see something moving on the road, and he whipped the Spad east and overtook it. The thing he saw was a two-wheeled cart drawn by a white horse. In front of it, at the animal's head, was a boy. The boy wasn't moving, and neither was the cart, piled high with cabbages and turnips.

The boy was looking up into the sky when the plane flashed overhead. He raised his arm as if to wave, changed his mind, and began to tug at the bit in the horse's mouth.

McCraig puckered his lips. Now where was that tomb of stones? He spotted the grayish blur ahead outlined for a second against a green hedge. There was no one near the monument, and the Spad wheeled around it like a predatory buzzard.

McCraig frowned. To keep this up was folly. It would only be a matter of minutes before the battery near-by would be investigating. His eyes lifted to the cloud pack above. There were no ships in sight. He studied the land. As far as he could see, there was nothing moving or visible but the boy and his high-wheeled cart, loaded with cabbages and turnips.

"Hell!" said McCraig.

He headed the ship into the wind and dropped. He gunned the motor for an instant, then its wheels were spinning on the ground. He fish-tailed around and headed back toward the stone monument.

Beyond it, on the road, the figure of the boy was moving over the high shoulder, into the open field. McCraig throttled the motor to idling speed, his eyes fastened on the boy. But it wasn't a boy. He was looking at a girl with tousled hair. She had come again to keep the rendezvous.

His heart hammered. He moved as though to unfasten the leather strap holding him to the seat. Abruptly, he stiffened, and the short hairs on the nape of his neck quivered with warning. To his ears came the drumming of motors.

The girl must have heard these, too, for she suddenly wheeled, and scuttled back over the shoulder of the road to her horse and cart.

McCraig's eyes were again riveted on the clouds above. He saw them come through, one behind the other—three swift Fokkers. Already his Spad was leaping across the field, gathering momentum with every yard. There followed a wrenching scream of ships lancing down in power dives, then the rattling staccato of Spandaus.

The stick moved back into the Spad pilot's lap. Up, up, up, jerked the ship through a snarling hail of metal. Overhead swept the first enemy plane. Behind it followed a second, taking up the dirge of death where the first had left off.

Black clouds of smoke belched from the Spad's exhaust. Up through the death trap bored the little plane.

In a whistling bank, the Spad slid away from the second burst of tracers. Then the third German ace struck. McCraig felt his ship quiver in the searing blast that ripped into the after-fuselage.

He reversed controls and skidded to port. A miniature cyclone centered around the ship, its core exactly in the middle of the pit. Joe McCraig jerked spasmodically. A tracer had seared a white-hot path across his shoulder.

"All right, Fritzie," he gritted. "You should have killed me. Now I'm going to kill you. Start praying, Fritzie!"

THE nose of the Spad reared up like a striking snake. Half around it whipped in a climbing turn. The red belly of the Fokker flashed like a live coal into the ring sights.

The twin Vickers rattled throatily. Two smoky streams tore through space. They sheared across the wings and splintered the pit just a few inches below the Scarff moulding.

The pilot behind the tripe's controls writhed impotently, gasped and clutched at a crimson smear above his heart. His Fokker keeled over, hung poised, then rocketed downward into a shuddering dive.

McCraig flung the stick over hard, thumped right rudder and wheeled the ship smack into another blast. Tracers beat a sullen tattoo along the trailing edge of the upper right wing. His eyes hardened. There was a green-and-white mottled ship off to his right. Where was the other? He bent his head back. There it was above him, a red ship with white wings, piqueing down in attack.

He shoved the throttle down, built up speed, flung the Spad around in a sudden *chandelle* and climbed to meet it. Like hissing comets, they winged each upon the other, only two hundred feet up. There wasn't room to maneuver. One false move, one instant of nose-diving, and they'd be burying their noses into the ground. To save a crash, they had to bank.

The air was criss-crossed with tracer streaks. The mottled ship had recovered and its guns were speaking out of turn—but speaking. McCraig could feel the jarring impacts of bullets on the undercarriage of his ship. His feet clamped the rudder bar. The Spad wavered, fell away, then droned in a great circle. All three ships were flying now in this same circle, each out of range from the other so long as they flew this way. But when one of them changed his course, cut across the circle, there'd be trouble for somebody.

Joe McCraig realized this. His eyes watched their shoulders. Through them would come the first telegraphic warning. Suddenly he caught the first movement—a slow hunching of the shoulder as the pilot in the red-and-white ship leaned over his controls. The stick was going over, to port.

A grim smile was on McCraig's lips. His own shoulder hunched. The stick centered, then jerked to starboard. The Spad heeled over.

But the German ace's maneuver was a feint. His ship swerved not a hair

line from its circular course. McCraig had been tricked out of position. His ship was tilting over, right wings low, left wings high in the air, and there was no red-and-white Fokker screaming past the ring sights. Instead, the mottled ship which hadn't figured at all was now in a killing position behind.

The Spad pilot discovered his error a split second after it was too late to correct his flight. But in that split second, the yammering guns on the mottled ship were pumping out hot slugs of metal.

They cracked along the top surface of right wing. The Spad trembled and began to rock. He jammed hard on right rudder. The ship sideslipped towards the ground. Both Fokkers followed it down. Their streams of lead crossed within a few feet of the Spad's club.

"Ummm!" grunted McCraig. His eyes were troubled.

He flung the ship into a vibrating lurch, threw right aileron and kicked hard on left rudder. Free for a fraction of a second, he gunned the Hisso with all the juice it would take, and clawed for altitude.

The crimson belly of a Fokker arched between the Spad's nose and the heavy clouds above. It was outlined there only for a moment. Down went McCraig's thumb on the Vicker's trip.

Bull's-eye! Smack into the center circle of the target went his stream of lead. The red-and-white ship would never fly again—nor would its pilot. It was tilting crazily in the sky like a tailless kite. Its Mercedes was screaming a song of fury.

But Joe McCraig wasn't hearing it. Something had happened. He didn't know what. He was in pain, in agony. There was thunder in his ears, and vivid lightnings before his eyes. There was a warm trickle beginning at his left temple. Salty liquid was on his lips.

Things began to swim before his eyes. Desperately, the wounded pilot tried to overcome the sluggishness enveloping his brain. He knew he was doing something, but what that was he didn't understand. His arm and leg muscles were mechanically taking up the tasks of flying. As though directed by the brain, hands cunningly worked sticks and fed petrol into the cylinders of the Hisso. Feet clapped on the rudder bars. The Spad rocked to an even keel and went howling in an uneven circle.

McCraigs's instinctive movements had saved his life.

The murk around his brain thinned. Sight, touch and hearing became a part of him. He was aware of his head pressing hard on the crash-pad. He was aware of surging power, of uplift, of cold winds fanning his face. His eyes blinked open. He couldn't remember when they had closed.

Gingerly he touched his forehead. A little more to the right, and that tracer would have smashed his skull. Vaguely he became aware of a violent trembling of his ship. There was a stuttering taccac along the tail assembly. He twisted around in the narrow seat.

Tracers! The mottled ship was be-

hind and slightly above. Its twin Span-daus were glowing with greenish flames.

Over went the stick. The Spad yawed flatly down the sky and the mottled ship followed, its guns hammering relentlessly. The tail of the Spad careened as the nose came around in a wing-tip bank. The motor coughed, flung out clouds of black smoke, spluttered and died.

McCraigs felt a clammy chill slither along his spine. The ground was coming up fast. He braced himself, hauled back on the stick and felt the wheels hit. The ship bounded, swerved and dug in with left wings. They parted from the fuselage with a brittle snap.

THE pilot leaped overside. He hit on his feet, stumbled and fell sprawling. Scrambling erect, he started to run, reached the hedge, crawled through it and found temporary shelter. Crouching low, he ran on, and almost collided with another figure—the girl in boy's clothing.

He skidded to an abrupt stop. "Arlene Mignon!" he gasped, staring at a small brown fist gripping an automatic that pointed at his heart.

"Please, *Monsieur* Joe. Do not move. It would be so hard to hurt you."

McCraigs straightened. He could look over the hedge. The mottled plane had landed. Across the field ran its pilot, a burly figure with a spade beard, shambling like a bear.

His eyes swerved back to the girl. "Do you mean it?"

Her brown fist was trembling. McCraigs could have taken the gun from her easily.

"Please, *Monsieur* Joe. You must understand. It will kill me to harm you. You must submit. Q-19—he is in peril. Only you can save him. You understand?"

McCraigs shook his head. "No." His eyes were on her little face. He saw tears come into her eyes. Fear, pity and utter frustration showed behind those tears. She sagged helplessly.

It was more than he could bear. "Okay, kid. I'll do what you ask. Now brace up. You won't have to kill me. Wipe those tears out of your eyes. Look at me—I'm laughing."

"I—I cannot laugh, *Monsieur* Joe. I am too frightened."

McCraigs stepped back. He could see the pilot with the spade beard crawling through the hedge. He could also see a steel-gray car braking to a stop on the road close to the horse and cart. He was caught—caught wearing a German uniform.

"Please try to trust me, *Monsieur* Joe."

"Don't worry. I'll get by somehow."

"*Lieber Gott!*" boomed the voice of the pilot with the spade beard as he charged down the hedge, his gun arm extended in front of him. He smacked his lips at the sight of the peasant boy covering the flyer with an automatic. "Gut, my boy. You've captured a dangerous *Espion*, one with a price on his head. Raise your hands, lieutenant. *Ach*, what a huge gun you carry! I'll take

it for my collection, if you please."

The girl dropped back silently to the hedge.

From the direction of the road came three men, an officer and two guards. The officer's face was thin, cadaverous. His nose was hooked like the beak of an eagle. He smiled icily on the group as he swung his monocle on its black cord.

"*Wie Schade*, eh?" He nodded towards McCraigs. "What a pity! And captured by a peasant boy! Our reports were that you were dangerous." He smiled in a knowing way at Arlene Mignon. Something seemed to pass between them as if they had a secret understanding with each other. He turned again to the puzzled flyer.

"A German airman, eh? *Ach, Gott*, what did you hope to gain by the uniform? We know you for a dangerous spy. The whole sector is aroused against you. Your friends—" he pointed over his shoulder to the south—"they have betrayed you, by wireless. Perhaps it was unintentional, but that doesn't matter."

"He's my prisoner," interrupted Spade Beard. "With my own guns I shot him down, and to my field he'll go as a prisoner."

The officer with the hooked nose regarded the German ace as one would a mangy dog. "*Ach, du bist ein Dumkopf!* Report to the *Herr Hauptmann* of your *Staffel* that you shot the *Amerikaner* down if you so desire, but also add that the prisoner is being held by German Intelligence. Is that clear?"

"*Ach*, so? Intelligence. *Sehr wohl*. Then take him away. Cut off his head, shoot him—but don't let him get into the air again. He's sudden poison. I will return at once to my field and make my report." He raised his hand in salute.

A moment later, his ship was bumping over the field in a take-off.

The hooked-nosed officer barked a sudden command. The guards moved in on the pilot, and the barrels of their rifles prodded the small of his back.

"Come," ordered the officer. "Your career is about ended. You're aware of that, eh?"

McCraigs stared gloomily at his wrecked ship. "That's the way it looks right now, Fritzie."

Herr Colonel Johann Haeckel, Intelligence chief of Alsace-Lorraine, peered through the thick lenses of his glasses when McCraigs was brought before him for questioning.

The officer with the hooked nose saluted smartly. "A prisoner, *Excellenz*, whom you've long wanted to capture."

"Ummm!" grunted Colonel Johann Haeckel, leaning forward with his elbows flat on his desk. "There are many, *Kapitan* Schwartz, I have wanted long to capture. And who is this one?"

Schwartz fingered his monocle. "*Excellenz*," he frowned, "I have every reason to believe that the prisoner is none other than the *Amerikaner Espion* known as Q-19."

"Q-19, eh?" The *Herr* Colonel's leer matched his voice. "Speak out. What have you to say to this charge?" he flung at McCraigs.

The sacrifice pilot rubbed the aching spot beneath the fresh bandage covering his head. "Nothing."

"Ach, Gott! You refuse to talk?"

Joe moistened dry lips. His mind raced as he stood stubbornly silent. The strange look that had passed between Arlene Mignon and Schwartz flashed across his mind. And the wireless—who had sent that damning message that had aroused the whole German front against him? Only two men knew he was flying over the lines in a German uniform—Major Soule and Captain Garth.

Had they betrayed him, sacrificed him to save Q-19? His brain was running away with ugly conjectures. Then he was jerked back to the present danger by the piercing voice of Colonel Johann Haeckel.

"Search this man thoroughly."

There wasn't much in the airman's pockets—nothing but a few sheets of paper containing the most damning evidence possible for one man to have in his possession.

The Intelligence chief scanned them hurriedly. His mouth twitched as he read the cryptic Q-19 at the bottom of the report. He picked up a small square of cardboard—an identity card which allowed the bearer to pass unmolested through the British, French and American front lines.

He raised his eyes and frowned. "And you again refuse to answer my questions?"

"I have nothing to say."

"Do you realize that it's a court-martial offense?"

A sudden commotion outside cut his voice short. A man entered, dressed in the baggy, unkempt uniform of a German private. He slunk in like a cat, his eyes ranging from one figure to another. His face was as coarse and unkempt as his uniform, yet his eyes were bright as steel filings.

COLONEL Haeckel made a motion to the guards beside the door. They moved outside and closed it behind them. There were now but four men in the room—the colonel, Schwartz, McCraig and the newcomer.

"Ach, von Eisner," purred the Intelligence chief. "I am glad you are here. Your presence is quite necessary. Where is Wirthmann?"

"Dead. I found his body in the hedge close to the stone pile."

"The Herr Colonel knows already," clipped Schwartz. "Where do you suppose I've been these last forty-eight hours?"

Von Eisner's eyes glowed craftily. "I wonder. At least you weren't on the spot when the forged documents were handed to the airman."

Kapitan Schwartz leisurely adjusted his monocle. "Forged documents? What are you talking about?"

"Just one of my little jokes, Kapitan."

"Der Teufel on you and your jokes," frowned Schwartz. He faced Colonel Haeckel. "We seem to be working at cross purposes, Herr Colonel. Am I entitled to an explanation?"

"Ja, ja. You are," said Haeckel.

"Listen, Schwartz, the game is finished. I know Q-19's accomplice—a girl masquerading as a boy. So I forged these documents in a cipher, and gave it to this girl. At first she was suspicious, but she took it and gave it to the Amerikaner airman who was sent over to get it. Simplicity itself. It worked beautifully."

Kapitan Schwartz rubbed his hooked nose. "Very interesting. But how do you explain Wirthmann's death?"

"Wirthmann didn't know what I was doing. He must have been on the spot and tried to prevent the airman from getting away. His body was riddled with machine-gun bullets, evidently from the airman's guns."

McCraig, only half-understanding the staccato gutturals, was aware of a growing tension in the room. His eyes swerved from Haeckel to von Eisner, then to the hook-nosed Schwartz, and he suddenly knew and understood the strange look that had passed between this German officer and Arlene Mignon.

There was a long moment of silence. It was broken by von Eisner.

"You're right, Kapitan Schwartz. Very interesting, especially what I have to say. Q-19 is no longer a mystery to the Wilhelmstrasse. I have his history down to the last detail. Care to hear it, Kapitan?"

Schwartz pointed languidly towards the Spad pilot. "We have him here," he announced. "Also documents which prove his identity."

Haeckel broke in. His voice was a high snarl. "*Ruhig!* Quiet. Do you think we are blind, Kapitan Schwartz? Q-19 is in this room. And he's not that pilot!"

Joe McCraig knew then for a certainty that trouble was ready to break. "Ach, Herr von Eisner," he laughed, walking slowly towards the man. "Kapitan Schwartz and Colonel Haeckel are both right. You are the one who is in error."

Von Eisner's lips curled. "Colonel Haeckel, I demand the immediate arrest of—"

Up from the floor in a curving arc swung McCraig's fist. It landed with a sickening thud on the underside of von Eisner's jaw. There was a harsh gurgle in the man's throat, then a slumping in the knees, and he sprawled insensible to the floor.

Schwartz moved with lightning speed. His gun prodded Colonel Haeckel's ribs. "Not a word. Understand?"

McCraig rubbed his bruised knuckles. "Showdown, eh? I'm Joe McCraig."

"All right, McCraig. I'll run the show from now on. Get a rag around von Eisner's big mouth, McCraig, and tie him up. You'll find rope in the bottom desk drawer. Work fast."

Joe McCraig worked fast. The job was done.

"There's a closet over in the farther corner," directed Schwartz. "Crowd him in and close the door."

The powerful drone of Benz motors sounded overhead. McCraig leaped to to the nearest window and stared up-

wards. A black Gotha crawled across the sky, followed by a Fokker. His heart hammered. Both machines were circling slowly.

Haeckel spoke for the first time. "You're a clever man, Kapitan Schwartz, but not quite clever enough."

"Danke Ihnen," mocked Schwartz. "Thanks."

"Do you remember the wires I had installed in my headquarters a few days ago, Kapitan?"

"Eh?" Schwartz stiffened.

"There's a switch under my desk connected with an air field down the road. When I closed the contact points with my foot, a light flashed on a certain switchboard. That plane you hear overhead is one sent out to investigate."

"There are two ships," called McCraig, "and one of them is a big Gotha bomber. The other's a Fokker, and it's coming down."

"Quick!" ordered Schwartz. "The gag!"

McCraig lifted the trussed body of the Intelligence chief from the chair and deposited it beside the body of von Eisner.

"Well, what do you say? Let's beat it."

Schwartz smiled bleakly. "Not a chance, around this outfit. They'd nail us before we even got started."

The telephone jangled a harsh note. Schwartz regarded it with calculating eyes, then picked up the receiver.

"Ach, no? Why did you not call my headquarters before?" His voice resembled Haeckel's so closely that McCraig started. "Repeat your orders again, Herr Hauptmann," continued the bogus Haeckel. "*Sehr wohl.* That is correct. And the hour? Sunset. Excellent. Do not call this office again until you have shown those Yankee *Schwein* the mailed fist of our Imperial Air fighters. Good luck, Herr Hauptmann. *Auf wiedersehen.*"

"What's the idea?" asked McCraig.

"Listen. I want you to get this straight, in case anything happens to me and you escape. Enemy ships are concentrating on the Woevre plains near Longuyon close to the railroad tracks. One line comes from Conflans, the second from Thionville. There's a triangle formed where the two lines meet. That is the point of concentration."

McCraig nodded. "I understand."

"From what I've learned, there'll be nearly a hundred and fifty ships, a third of them bombers. It's the biggest concentration of ships so far in the war. They'll be coming over in three groups at sunset today. Destination unknown. Got it?"

"Sure. Well, we can't stay here."

"Hardly," snapped Schwartz, turning to Haeckel's desk. Feverishly he pawed at reports, orders and other items of information. Abruptly he stiffened, crumpled a sheet of paper in his hand and stuck it in his pocket.

"I guess my work's done, McCraig. Here's my death warrant. Haeckel must have been aware of my activities for the past two days. Take another look at the window and see if those ships

are landing. Can you see them?"

"Can't see the Gotha, but the Fokker is already on the ground, and the pilot is out and coming towards this building."

THE door crashed open. The pilot with the spade beard entered. He looked closely at both men. Schwartz lounged indifferently behind Colonel Haeckel's desk. McCraig stood against the wall, his hands behind his back as if bound.

"*Lieber Gott!*" The pilot with the spade beard fondled an ugly automatic. "Where is his *Excellenz?*"

The burly guards who had stepped outside at Colonel Haeckel's command moved in. There was a double thump as the butts of their rifles hit the floor.

"Colonel Haeckel," observed Schwartz, calmly lighting a cigarette, "has gone to his quarters."

"*Nein, nein,*" spoke one of the guards. "He could not have left without my seeing him. He is here in this room. And *Herr Leutnant* von Eisner is with him."

The eyes of the German ace ranged the room. Only one other door was visible—the closet door. "Open it," he commanded.

The hobs on the guard's boots clicked across the stone flagging. In another second his hand would be on the latch. McCraig jumped sideways, spun and lashed out with a round-house swing. The guard dropped with a mumbled groan.

The automatic in the Fokker pilot's fist rattled deafeningly. A bullet whistled past McCraig's head. His feet found traction. He bent low as he charged across the room at the remaining guard. Schwartz leaped to the desk top, swayed for a moment and flung himself on the Fokker pilot. They crashed to the floor.

The pilot with the spade beard let out a yelp of fury. Schwartz smashed him in the mouth. Like a maddened ox, the German ace thrashed about the floor. There were cries of alarm on the field outside, followed by the pound of running feet.

McCraig gave a final squeeze on the throat of the guard under his hands, and flung him aside. With a lurch he staggered erect. There was a bluish automatic on the flag stones. He grabbed at the butt, reversed his hold and brought it down hard on the thick skull of the thrashing German ace.

The face of Schwartz was white as he staggered to his feet. "Thanks, McCraig."

Joe grinned. "What's next?"

"The Fokker. It's our only chance. Walk slowly. Keep your gun handy, but out of sight. And don't run."

They moved out of the building. Gray-clad figures were coming towards them on the run. Schwartz stopped them with an upraised hand. Coolly he adjusted his monocle.

A spy had escaped, he told them. Had they seen a man running swiftly? He indicated the road. They had not. And what was more, they refused to believe anybody had escaped. They had

heard shots in Haeckel's headquarters and they were on their way to investigate.

McCraig could see the Fokker's propeller turning slowly less than a hundred yards away. Freedom was that close. An officer with a squad of men moved briskly on their flank. There was still some doubt as to what had happened.

McCraig tilted his head sideways. The roar of Benz motors was again in his ears. His eyes swerved up just as the huge, black fuselage spiraled downwards. Something lean slid from the Gotha's belly.

There was a blinding, swirling crash. The concussion knocked them sprawling. Smoke cleared. One of the barracks buildings housing the guards of headquarters was flaming.

Raucous cries sounded, then high-pitched orders from Colonel Haeckel. The pack was loose!

McCraig scrambled to his feet. Schwartz was a trifle slower. Joe helped him. They stumbled towards the Fokker. There was a sound of a barking gun somewhere behind. Schwartz stumbled again.

McCraig, in the lead, turned back. "Hurt?"

"In the leg. It's broken, I guess. Can't move. Don't wait for me. Beat it to the Fokker. Hurry!"

"Like hell!" McCraig bent down, gathered the injured man into his arms and staggered towards the ship.

Something arched for a moment across the dome of the sky—a slim projectile. It missed headquarters behind them, slanted over their heads with a faint swish, and nosed into the sleek form of the Fokker.

Blampf! The Fokker disappeared from the face of the earth, and again concussion breathed its mighty breath in the staggering pilot's face. Fumes of burnt powder stung his throat, and he weaved groggily. The man in his arms twisted. The pilot forced himself to look down. The eyes of Q-19 were closed.

McCraig's lips moved in a soft curse. Feet braced wide apart, he stared through smoke and swirls of dust kicked up by the circling bomber. The shrill voice of Haeckel reached his ears. It was only a question of time now. This was the end.

The roar of motors deafened him. He jerked his eyes from the horde pouring from headquarters and stared with grim fascination at the black hulk. It was winging in a tight circle, its left wings sagging low. There was a helmeted head visible behind the open-work cooling jacket of a pair of Spandaus.

Even as McCraig stared, he saw those muzzles bathed with orange flame, and felt a hoarse drumming in his ears. Had the whole world gone mad? The gunner was firing in the wrong direction. He was turning loose Spandau tracers in the direction of headquarters—at Haeckel and his armed guards.

The gray horde was barging smack into a storm—a storm of molten metal. It cut them down with savage fury. A

few escaped and ran screaming to the nearest shelter.

Back and forth droned the bomber in tight banks, slicing the air with its death chopper. Now it was coming to the ground, its twin Benz engines rumbling throatily, its hulk making a furious swishing against the wind. The tires screamed protestingly as the ship ground-looped to check its speed. Back towards McCraig it rolled, and a heavy-jowled face hung over the pit's edge—Garth's.

The ship was coming towards him fast. McCraig was engrossed on the man he held in his arms, wondering if he could lift him to the pit of the machine.

The black prow roared past in a blur, then the lower wing. McCraig saw it too late. Its forward edge struck his temple where the blood-soaked bandage covered his head-wound, and the world rocked in its orbit in the shattering second that followed.

Then he heard Garth's booming voice. Feet hit the ground. Hands were around him, and he was being lifted. Then he was over the edge of fuselage and wedged against curving ribs.

He opened his eyes. Everything was black. "Schwartz," he called, thickly. "Did you get him? He's Q-19."

Garth's big hands had already jammed the throttle. The roar of the powerful engines smothered the pilot's words. He was conscious of a jerking and bumping. Then everything was smooth again. The Gotha was in the air.

FOR the next half hour Joe McCraig lived in a sort of a twilight, but all the time he could feel stirrings in his brain of something half-forgotten. The ribs of the fuselage jarred him. Wheels were spinning. The Gotha had come to a landing. There was a curtain before his aching eyes, like a nebulous film of twisting folds.

Garth's voice reached his ears. "Can you climb down, McCraig?"

Joe tottered erect. Garth's hulk towered in front of him. There was another figure beside him. They were lifting the body of a third man from the floor—lifting it over the edge of the ship into waiting arms extended up from below.

Slowly, McCraig climbed to the ground. The mist before his eyes partially faded, he could see a little better. But the stirrings were still in his mind as the field surgeon cleansed and bandaged his wound.

He found himself in the operations office afterwards. Garth was asking him questions.

"Listen, McCraig, Q-19 is out of the game, unconscious. Will be for many hours. Tell me what happened. Quick!"

Joe's voice was bitter. "They knew I was coming over, Garth. Wireless tipped them off. Wireless from—from—"

"From my headquarters," finished Garth. "Sure, I framed you. I wanted German Intelligence to think they had captured Q-19. Later on, I knew I had done you a terrible injustice. Knowing you'd be taken to Haeckel's headquarter—"

ters for questioning, I flew over in a captured Gotha. The rest you know. Now go ahead."

"Three Fokkers ganged me the moment I reached the stone tomb," continued Joe. "I shot down two, then was shot down myself and taken prisoner. Schwartz, himself, took me to Colonel Haeckel's headquarters. They had me cold when they found the papers you planted on me."

"Go on. What else?"

"A Wilhelmstrasse agent came in. He had the dope on Schwartz. It was then that I knew Schwartz for Q-19. The showdown arrived. We overpowered Haeckel and his agent, von Eisner, bound them, and shut them in a closet."

He paused as he tried to keep his mind fastened on those tense moments. "I know! I know now what it was!" His face brightened as the stirrings in his mind crystalized into concrete facts. "Schwartz was talking at the phone. A Fokker was coming down to investigate an electrical signal indicating something was wrong."

"Well?" snapped Captain Garth, impatiently.

Joe rubbed aching eyes. The shadows were coming back. "The point of concentration," he continued, dully, "is on the Woevre plains, in the triangle caused by two intersecting lines of railroad tracks. One comes into Longuyon from Conflans, the other from Thionville. Where the two meet—that's the start-off."

Garth reached for the phone. "What else, lieutenant?"

"The hour for the attack is sundown tonight. They're coming over in three groups, at least a hundred and fifty ships—a third of them bombers."

But Captain Garth was no longer listening. He had picked the receiver from the hook. "Commanding General of the Air Service," he was drawing.

In the interval of waiting, he turned to McCraig. "We've been expecting this, lieutenant. In half an hour our own huge fleet of ships will be in the air, and the mightiest battle of the air—"

He turned back to the phone. "Hello . . . I want to speak to the general personally. Yes, hurry . . ."

Joe McCraig lurched to his feet, and walked out the door to the field. There were other stirrings in his mind, something he must do. He hadn't time to wait for Schwartz to recover from his wounds.

Arlene Mignon—he must go out and bring her in.

A face blurred before his aching eyes—the face of von Eisner with his glittering eyes, his slinking walk, his big, coarse mouth. The Wilhelmstrasse agent would be on his way to make a prisoner of the girl. At the thought of it, McCraig broke into a run across the field where he could dimly see a Spad. The propeller was spinning slowly.

Men shouted at him, and two grayish blurs of mechanics ran towards the Spad. McCraig reached it first, slid inside the pit. Down went the throttle, and a blasting roar resounded. The ship

trembled, climbed the chock blocks, and roared down the tarmac.

The wind lashed his face. It seemed to tell him to go back before it was too late. Mechanically he snapped the fastenings of the safety belt. Over the cowlings he peered and saw—nothing. He held his hand before his eyes. He couldn't see it.

"Blind!" he breathed, helplessly.

He felt as he had when in the Gotha. Everything was pressing in on him. Fear squeezed his heart. He moistened his lips. Horror froze him to the controls. He shook his head doggedly. He wouldn't give up. As long as he kept the ship in the air, he was safe.

Slow minutes dragged, and the Hiss moaned softly as the Spad wavered on through sky trails, a ghost ship lost in the upper void.

HOW long he flew in this dark stretch of loneliness, Joe did not know. But when it seemed that he could stand it no longer, his ears picked up a thunderous beat of motors.

The shadows before his eyes thinned. Faintly through the last hour of the day he could see the glowing red orb of the sun. There were objects passing before it. Squadron after squadron of V flights. They were passing overhead in a straggled formation.

Joe whipped his ship over in a sharp bank upward. As long as he could see, however faintly, he intended to follow his comrades. There was no doubt in his mind where they were headed—Longuyon.

He attached his ship to theirs as a sort of a rear guard. Presently, as vision cleared a little more, he saw other squadrons soaring up from below. The sky trembled with the thunder of motors. He soon found himself hemmed in from behind as more and still more ships joined the sky parade. Spads, Nieuports, Camels, Dolphins—anything that could be flown was in the great armada.

There was a gray Spad high above the rest. Orange streamers of silk whipped back from the bandeau around its pilot's head. There was a flight of canary-yellow Spads flying at point. To them would go the honor of the first blow, of splitting into the serried ranks of Fokkers, Albatrosses, Pfalzes, Rumplers and Gothas.

Through the smoke of many exhausts droned the half-blind airman's Spad. There were grains of pepper in the sky to the north. They grew, expanding into a black cloud that whipped southward with the speed of a hundred mile an hour gale. Red, green and blue signal flares arched across the dome of the sky. Squadrons were shifting into battle formation.

Squinting into the sunset, Joe could see the three sections of the German air-war machine, one above the other. They seemed to cover the whole northern sky. Then, suddenly, there was no space at all between the two vast air fleets.

A flight of canary-yellow Spads disappeared into a welter of Fokkers. They made a deep hole. Other ships crowded

into it. The lower section of the vast German fleet parted in the middle as if welcoming them.

Down settled the second section from above. A cloud of Spads and Nieuports winged in fast, turned it aside and split the whole German air fleet into two separate parts.

McCraig found himself in a maelstrom of diving, twisting ships. Confusion cluttered his brain, but his hand clenched the stick. Into the ringsights barged a Pfalz. The Vickers croaked hoarsely. Cherry-red tracers snarled from its twin muzzles. The Pfalz faltered in mid-stride and went sagging down through space.

McCraig rubbed his eyes. A big hulk cut in, and the Spad pilot found himself diving on the broad back of a Rumpler. The Rumpler's rear gun, swinging on its cradle, described an upward arc. Tracers slashed into the bottom of the Spad's after-fuselage.

The Spad leaned, spun on wing tip and blundered into the path of a bottle-green Fokker. Brrr—ack! The Scarff moulding before McCraig's face went whipping off into space. They passed so close that the tips of their wings clicked.

The Spad whipped around, lanced a second Fokker with a vicious burst, climbed over it and nailed the pilot of a third. The nose of the Spad, at the exact moment the gun trips went down, was pointed squarely at the chest of a white-faced German pilot. In that brief second, McCraig saw terror, pain and unutterable woe pass over that face.

It troubled him to see the hurt he had caused, but there was no going back. As he raised his fingers to helmet in salute, he caught sight of a Gotha that swam below. The huge bomber was lost in the maelstrom of swift pursuit planes. The Spad nosed upon it, tail lifted high. Through two streams of bullets it sped. Dodging the wide lift of Gotha wings, the small ships curved under its belly, and wrenched upward in a climbing *chandelle*.

In dizzy circles the Spad climbed. Without helmet or goggles, McCraig's face and eyes were totally unprotected. Grimly he stared about him. An opalescent haze hung over everything. He could no longer see the sky, nor could he discern the outer edge of the gigantic dogfight. Only those planes that were in a radius of a hundred yards were visible to his aching eyes.

His vision was narrowing again. Once more the blood from his headwound was pressing down on his optic nerves. He could feel the world withdrawing minute by minute.

He gasped as he left the sudden terror of approaching blackness. There was no sky, no ground—only the howl of motors and the brittle rack of guns.

The face of Arlene Mignon fitted across his mind. He heard again her voice, and saw her tragic eyes. "I—I cannot laugh, *Monsieur* Joe. I am frightened."

The poignancy of her cry was like that of a lost child. It wrenched his heart more than any physical pain. Memory of her brought back his rea-

son for taking to the air. He had yet to save her from von Eisner.

Was it too late? His blurred vision made him useless in the battle of the skies. To remain was folly. He had to go down, seek her

JOE McCRAIG stared at the instrument panel. Petrol was getting low. He had been in the air an hour and a half at least. Thirty minutes or less of flying time were left him. His vision was failing. At any moment things might go suddenly black.

Down dipped the Spad, banking, twisting, sideslipping, as it dropped through the sunset sky. Bright-winged battle cranes scurried from its path. Spandaus slugs pawed at its wings, at its pit, and the pilot within the pit. Down, down, down it sagged, brushing wings against wings, trading tracer for tracer—but always pushing towards the carpet.

Ships with stuttering guns followed him down. McCraig, sensing his peril, cut the motor and forced his Spad into a spinning *vrille*. His pursuers, thinking his plane was out of control, returned to the upper stretches. The speed of the *vrille* meanwhile increased. The tail was whipping madly in concentric circles around the nose. In another minute he'd lose all control.

He moved the stick backward, shoved it right and left. He worked rudder bars, but the spinning motion continued. His lips formed a straight line. He jammed the throttle wide. The propeller bit into the air. Then, as the motor took up its task in earnest, the Spad climbed down-sky on leveled wings. The deadly *vrille* had been conquered.

McCraig hung his head over the edge of the pit. Something blurred before his eyes. He dropped the ship lower. A plowed field littered with flaming wrecks of ships was visible. The Spad heeled over. Dimly, the brownish ribbon of a road floated before his eyes. Was this the road leading to the monument of fieldstone?

At the risk of crashing against a telephone pole, Joe dropped his ship still lower. He careened along it, looking, hoping, praying for the thing he wanted most to see. And instead, he saw a gray touring car.

From the back seat of that car three gray-clad men peered upwards. The Spad dipped closer. The pilot strained his eyes.

"Von Eisner!" he gasped.

An automatic and two Mauser rifles were suddenly pumping bullets. Lead thudded against wings. The Spad's nose had already passed over the speeding machine, so guns were useless. Even as McCraig's foot jammed rudder bar, a bullet found him. It smashed up through the floorboards and burrowed into his leg. The burn of the white-hot metal made him a killer, for the last time in his life.

The Spad whipped on its side in a wrenching wing-over and arrowed back along the road towards the swaying, steel-gray car. Its nose dipped. A hoarse cough rattled from the glowing snouts of the Vickers, and the car-driv-



A LITTLE NEWSPAPER DEVOTED TO A BIG CAUSE ★ OF, BY AND FOR FLYING ACES CLUB!

VOLUME 8

JANUARY, 1935

WHOLE NUMBER 17

NEW AVIATION SECTION FOR FLYING ACES

Plans Being Made for F.A.C. Rifle Contest

The recent inquiry that appeared in this little newspaper in regard to the popularity of an F.A.C. rifle contest brought forth a deluge. As a result, plans are being formulated as rapidly as possible for this new activity. It takes time, however, to make plans that will be absolutely fair to all who desire to have such a contest. And unless it is going to be run fairly, we want to have nothing to do with it.

There is still a question about the caliber of rifle to be used. We want to hear from you fellows who have not as yet sent in your entries. We have to know whether or not you want us to hold this contest; whether or not you have a rifle; if so, what kind and caliber; if not, whether you expect to get a rifle, and the kind and caliber that you prefer. To make it easy for you to get in your entry and to give us the necessary information, fill out the coupon at the bottom of this page without delay and get it in the mail. Do it now, won't you?

Maj. Macpherson, D.S.M. Gets New Advertiser

Some time ago, Major Macpherson, D.S.M., of Hamilton, Ontario, decided to work for his D.S.M. by getting new advertisers to use FLYING ACES. He made up his list of advertisers and started to write to them. And if they failed to respond, he wrote again and again until he did get an answer.

Did you notice the initials after the Major's name? Yes, he won the D.S.M. It was presented to him a couple of months ago by the National Adjutant when the Major was in New York. The first advertiser to be convinced of FLYING ACES' value by the Major's letters is Karl Ort, whose advertisement appears in the Buyers' Directory.

Aces Up suggests that there are D.S.M.'s waiting for some of you other fellows. And you should be able to win them as easily as did Major Macpherson.

This issue of FLYING ACES heralds the advent of a new advertising section, the new Buyers' Directory for air-planes, accessories, aviation and flying schools. There's a selfish motive in this. We need more advertisers, especially the aviation companies. Like many much larger business organizations, these companies have been forced to reduce their advertising expenditures.

In the face of this situation, FLYING ACES is glad to do its share by establishing this Buyers' Directory, in which the rates have been materially reduced. This reduction gives FLYING ACES a lower rate in proportion to its circulation than any other aviation magazine.

Advertisers, however, are human. It's easier for them to keep on advertising in those magazines they have been using right along. For that reason, those advertisers you will find in the Buyers' Directory are especially deserving of your patronage. They are the first to recognize the true value of FLYING ACES' Buyers' Directory. When you finish reading this page, turn to the Buyers' Directory and read the advertisements. They advertise, we'll patronize.

Have You Registered Your Plane at G.H.Q.?

It is too early as yet to have received any inquiries to our request that appeared in the December Contact Page for plane owners to register their ships at National Headquarters of the F.A.C.

Word comes, however, from Edwin Elder of Chattanooga, Tennessee, that he is a member of a club owning a Taylor Cub.

Come on, you plane owners, get your ships registered in the F.A.C. National Airplane Registry! This applies to you, whether you are an individual owner or whether you belong to a club that has a plane. Just drop a line to the National Adjutant of the F.A.C. at GHQ and tell him what kind of a plane it is. If possible, enclose a picture of it, with yourself standing alongside or sitting in the cockpit.

ACES UP—FLYING ACES Magazine, 67 W. 44th Street, New York City

Are you in favor of an F.A.C. Rifle Contest?

Do you own a rifle? Kind? Caliber?

Do you expect to buy a rifle? Kind? Caliber?

Name

Address

er collapsed in a riddled heap.

The steering wheel, with no hands to steady it, spun loosely. Then followed a lurching twist as the front wheels skidded across the road. Then a wrenching smash as they climbed an embankment and thudded into the solid trunk of a tree.

Joe banked the Spad around and swept back over the road. It was increasingly difficult for him to see clearly. The road was empty, but off to one side where a big tree stood guard, he made out a crumpled heap of grayish metal, bent and twisted out of all shape.

The road flowed backward beneath the winging Spad. It was becoming familiar. There were the trees with the sheared tops. Beyond them he'd find the stone monument.

A horse and cart came into sight, standing motionless, below. His heart beat wildly. Was he too late?

In a wrenching bank, the Spad curved around, while the nearly blind pilot searched for the thing that mattered most in a crazed, war-torn world of madness. Then he saw it—a kneeling figure, slight and bowed.

The kneeling girl beside the stone pile straightened as the Spad's motor whined over her head. She waved her hand and leaped to her feet.

The wheels hit the ground and rolled swiftly away from her. She ran after them, her *sabots* clacking against the hard clods of the field. Above the edge of the pit she could now see the bandaged head of the pilot. His face was turned towards her. He appeared to be listening. The Spad rolled to a dead stop.

She cried aloud as sudden premonition told her something was wrong. "Joe! Joe! *Monsieur* Joe! What ees the matter? It is I! Arlene Mignon!"

"Arlene!" His hands groped downward.

She reached up and grasped them. "You must come with me, Arlene," he told her. "Your life is in danger. You are known as an accomplice of *Kapitan* Schwartz. The Boche are on their way to arrest you. I wrecked their car, but there will be more. You'll have to climb into the pit. I'll take you—"

"But *Kapitan* Schwartz—where is he?"

"Wounded, but safe within the American lines."

"*Merci*. Now I go with you. And you take me to *Kapitan* Schwartz."

Nimble she climbed over the side of the pit. Two thumps on the floor of the pit made the airman jump. "What was that?"

"My *sabots*. I drop them. So!" She laughed as she wedged her small body in beside him. "Why do you not laugh? You do not look at me, *Monsieur* Joe, but at the sky. Why? I look funny, *non*?"

"You're beautiful. But I can't see you. I look at the sky for light, and I see nothing but darkness. I am blind."

"Blind? *Aveugle*?" Her voice faltered. A muffled sob twisted her lips. "Please, *Monsieur* Joe. I cannot but feel sad. But I will not despair. Arlene's eyes—they are like the hawk's. Always they will watch for you. Now—let us go away from here."

Joe's eyes were still on the invisible sky. "Do they still fight up above?"

"*Non*. The Boche they were destroyed. They flee. Your comrades they have drive them from the air. It is victory." Her lips moved close to his ear. "I think of you, *Monsieur* Joe, all the time. I wish for you to come to me. Now I am not frightened. You take me to *mon frère*. Is it not so?"

"Your brother?" Joe could hardly believe his ears.

"But yes. *Mon* brother, Paul. You call heem *Kapitan* Schwartz."

A ghost of a smile flickered over Joe McCraig's face. So she was Q-19's sister! No wonder there had been an understanding between them. He moved the throttle down. The Spad skimmed across the field, lifted into the wind, banked and headed into the east.

"*Non, non*," said the girl, gently. "More this way, south—towards Arlene."

Her small brown fingers closed over his own, gripping the stick, and there they remained. Her cap disappeared into the backwash of the prop. Joe felt her loose curls whip against his cheek. He blinked his sightless eyes, but he was smiling now. And though he couldn't see her face, he knew she was also smiling.

She pressed her face tightly against the shoulder of his tunic, and he knew then that she'd always be with him, that she had come to stay.

"Look below," he commanded. "Tell me what you see?"

"*Pourquoi*? Why?"

"Are you not my eyes?"

She laughed softly and peered over the pit's edge. "I see a road climbing a hill. I see a pond, and *Monsieur* Pierre's farm."

"We've got to pass over that farm. Which way shall I turn—right or left?"

"To the left."

"Good. Soon we will be at the field. It's smooth, with low flat buildings. *Bremcourt*."

"It ees still many meters. I will tell you when we are there. Now, I can rest." She settled back with a sigh, relaxed, confident, her hand on his sleeve.

And Joe McCraig, head erect, sightless eyes staring straight ahead into the dusk, had no fears, no doubts. He was headed for home. He was ready for the dangerous task of bringing his ship down to the field's tarmac. Somehow, he knew he would not fail.

At Suicide Pass

(Continued from page 17)

corrected. "I'm not a colonel by choice."

Thompson's eyebrows lifted. He liked Boomerang for that speech. He had found it easy to like and hard to hate Boomerang, anyway. So, when he spoke, he was almost friendly.

"I guess you'll be going over Suicide Pass before long, won't you?"

Boomerang rose to his feet and yawned, tapping his pipe with a practiced hand. Then he moved away, swinging that right foot in a small arc with each step. As he did, he said, "That's your guess, Thompson. Maybe it's as good as any, at that!"

FOUR days later, Boomerang gunned his crate through a rapidly clouding afternoon sky. An hour at the most and a rain would be over the Front. He handled his Spad in a careless way, but his eyes were alert, ever keen. Behind him, Thompson was in the observer's pit.

Suicide Pass was far to the left, and Boomerang Conners gave it a wide berth. And Thompson felt his anger against the man rising. There could be only one reason for Boomerang's caution—he wanted to live to see Major Ayres demoted.

On and on the Spad flew. Far to the left, Conners could make out the narrow pass that was the open graveyard of so many of the 39th's pilots. But he gave it scant attention, for clouds gathered about them more solidly with each minute.

Then, in the mist, he saw two specks. They gunned with the speed of gnats, growing larger rapidly. Behind them appeared three more specks, which flew even faster than the first two. Obviously, the first were attempting to escape from Suicide Pass. They were the only ones who had ever been known to return even that far.

Instantly, Thompson was all eyes.

He tapped Boomerang on the shoulder. "It's Captain Bloor and Lieutenant Abbott," he screamed. "The C.O. sent them over to try to get pictures of what is beyond that pass. They've succeeded, by all that's holy! And now those Boche are on them—three of them, too. And their crates are as heavy as—"

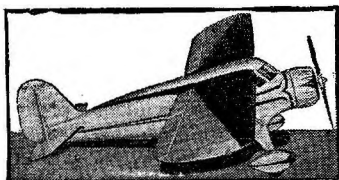
He broke off spontaneously. Boomerang had turned his back on him. Was the man mad? Didn't he want to save those pilots? Desperately Thompson pulled him about.

"Get over there so we can give them a hand," he shouted, whipping his bound Lewis into position. "Give it the gun!"

Boomerang shook his heavy head. "Against rules for an observation crate to barge into a dogfight," he returned, and again turned his back.

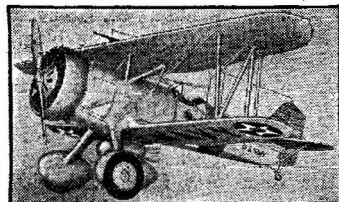
"But damn it, man, those pilots are—" Thompson suddenly realized that no matter what he said, Boomer-

Here's the PLANE YOU'VE been waiting for THE New, FAMOUS SUPER-DETAIL Martin Bomber



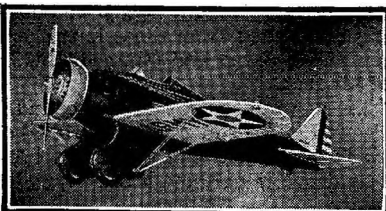
STINSON RELIANT

Wingspan 32 5/16", length 21 1/4", weight 3 1/2 oz., exact 3/4" scale. Here's a plane you'll be mighty proud to own and fly. An exact reproduction of one of the latest 4 passenger cabin planes. You'll find more unusual and different features in this plane than in any other. For example—adjustable speed arresters built into the wings, the movable cabin doors, the complete interior with four seats and control column, and all the other Super-Detail features. Colored in bright contrasting yellow and black. Kit complete, postpaid..... **\$2.50**



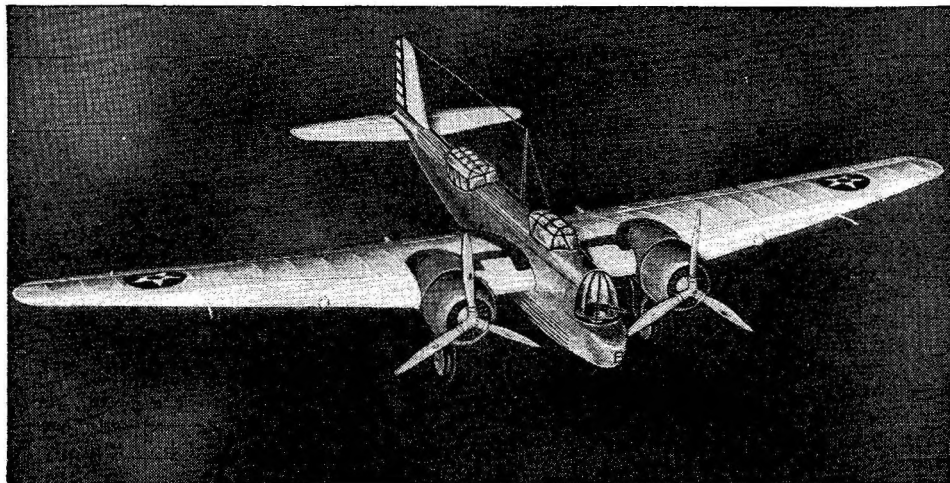
CURTISS GOSHAWK

Wingspan 23 3/4", length 16 3/4", weight 3 3/4 oz., exact 3/4" scale. You've heard of this beautiful Curtiss Goshawk. Now you can build your own with the most complete kit you ever saw. This snappy little Navy fighter has many more details than you can see in the photo. Everything designed in exact scale of course. Streamlined drag ring specially designed; two detachable blade propellers, and the entire model coated with the new IDEAL high lustre finish, with silver, yellow, red and black coloring. Plenty of material is furnished. Kit complete, postpaid..... **\$2.00**



BOEING P-26A

Wingspan 21 1/4", length 18", weight 2 1/2 oz. Exact 3/4" scale. One of the newest, most advanced of all fighting planes. Fast, speedy, with full armament capable of over 240 miles per hour. This flying model is an exact replica of the famous fighter—one that is identical in all but size with its noteworthy big brother. Beautifully colored in olive drab and yellow. All Super-Detail parts included. Kit complete, postpaid..... **\$1.75**



Wing Span 35"—Length 22 1/2"—Weight 4 1/2 oz. Kit Complete **\$3.50**

IDEAL brings to you, with all the Super-Detail features and many new exclusive fittings, this famous big, powerful, mystery ship of the army. Beautifully designed, strikingly colored in high luster Olive Drab and Yellow, the Martin Bomber plane has more new and beautiful features than any model you ever saw—one of the most complete flying models ever built.

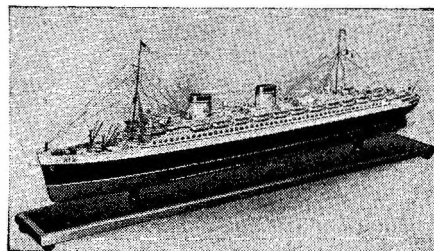
In addition to the controls which you can actually work from the cockpit—which operate elevator, rudder and ailerons just like the big planes, the Martin Bomber has retractable landing gear, rotating gun turret, movable machine guns, special streamline cowlings, two types of 3 bladed propellers—one for flying and one for exhibition with removable motor sticks for flying; rudder and elevator balanced surfaces; new type freese ailerons—all in all one of the finest, most complete flying models ever built at any price.

Designed by experienced flyers—men who have spent their lives designing and building real planes, IDEAL Super-Detail planes have all the features of their big flying brothers. Also the new and exclusive Super-Detail fittings such as—ailerons, rudder and elevator can be set in any position desired for flying and controlled by cables from cabin—IDEAL bright high luster finish—pulleys—control horns—control cable—streamline drag rings—exact scale wood wheels—everything an exact duplicate of the big flying planes.

That is why you really learn the principles of aviation when you build planes the IDEAL way... that is why they are exact reproductions, perfect in every detail, why experienced model builders prefer Super-Detail kits. That is why IDEAL received serial number one and was the first to be approved by the Junior Birdmen of America.

Send the coupon today for any of the kits pictured. Everything necessary to build a big, beautiful, workmanlike flying job, included in the Super-Detail kit. You only have to follow the complete and simple instructions to obtain extraordinary results.

Another NEW Super-Detail model
... the Italian liner REX.



29"—scale 1/32" to the foot.

An exact replica of the new and beautiful Italian liner... this Super-Detail 29 inch model has a shared hull and over 100 metal fittings, 24 cast metal lifeboats; 24 cast stairways, 2 cast anchors; 4 metal propellers; 6 cast bits; 48 metal davits. The Rex comes in beautiful high luster original colors of black, orange, white, red and green; and the kit also contains turned wood parts, printed wood, cement, wood filler, sandpaper, etc. It has full sized plans with complete instructions and 7 photographs illustrating the different stages of construction. A beautiful model, easy to build, for all the hard work has been done for you. Kit complete, postpaid.... **\$6.00**

WHAT THE SUPER-DETAIL KIT INCLUDES:

Everything necessary to build a big, beautiful workmanlike job is included in the Super-Detail Kit. Finest materials only are used in its construction. Sheets of selected plainly printed balsa, strips of various sizes, etc. sheets of silk tissues, cement, both colored and plain dope, propeller shafts, two propellers, motor plate, rubber motor, wheels, cable cord and all other hooks, pulleys, control hinges, eyelets, washers, sand paper, celluloid, reed, wire and other small but necessary things to make the complete model exactly in accordance with the plans and instructions.

IDEAL AEROPLANE & SUPPLY CO., INC.

21 West 18th Street, New York, N. Y.

Pacific Branch:
Model Boat & Aircraft Co., 1356 Fifth Ave., San Diego, Calif.
Canadian Branch:
Canadian Model Aircraft, 3007 St. Antoine Street, Montreal.

ILLUSTRATED FOLDER —Send 3c. for the new IDEAL folder showing the latest model IDEAL Planes. It contains valuable information on how you can make real money by building and selling these famous flying models.

DEALERS: You can make more money with IDEAL products. Write for details of more than 100 model airplanes & ship models

See your local dealer or send this coupon

IDEAL AEROPLANE & SUPPLY CO., INC.
21 W. 18th St., New York City.
Please send the items I have checked. I am enclosing \$.....
(West of Denver 25c extra. All planes postpaid.) Canadian Prices 40% higher to cover duty.

Martin Bomber \$3.50 Curtiss Goshawk \$2.00
Boeing P-26A \$1.75 Stinson Reliant Airliner \$2.50
Folder with information 3c Rex \$6.00

Please print name.....

Address

City, State.....

ang would not attempt to save those pilots. A flood of indignation and horror swept through him, and with a curse he whipped out a heavy Colt and jammed it sharply into the pilot's neck.

"Now, you get over there," he commanded fiercely. "And do it in a hurry. Those men got the pictures the C.O. wanted, and we are going to see that they take them safely to Major Ayres. Gun—fast!"

Somehow, Boomerang seemed to sense that Thompson was only too willing to pull the trigger, and a hidden grin passed under his stubble of beard. He kicked his rudder bar and turned left, the heavy Hisso roaring under the pressure of his fist.

Long before they had reached the crates, the fight had started. Both Bloor and Abbott were in tight places. Outnumbered, they were also out-fought.

One Boche in particular was a fighting fool. He was everywhere where he could do the most damage. And from the outset it was inevitable that the two Yankee pilots were doomed.

Then Boomerang was upon the mill-ing crates. He could see that the scrappy Boche flew a red crate, a Fokker tripe. He maneuvered it as though it were a part of his body, and pounded his Spandaus so viciously that the sky became a hive of lead.

Whizzzz! The red Fokker roared off the wings of Boomerang's Spad. Rrrrrrrrr! Thompson sent a tonic of tracers spraying after it, as Boomerang jerked his stick back. Every strut and guy in the crate whistled eerily as he gunned after the Fokker.

Boomerang's fingers closed about his Vickers trip. It yammered and pounded under the pressure. Fire danced off the iron nose. Once, twice—and the Fokker slid back in its climb, rolled over, and started down with a wild scream.

It was at that moment that things began to happen—things Thompson could scarcely believe. Well beyond the German ships, Abbott's Camel, not fired upon by anyone, suddenly opened in a spray of fire—fire and explosion almost simultaneously.

It caused even Boomerang, hardened corsair of many sky battles, to blink.

Many were the weird tales of the mysterious fires over Suicide Pass. But this was miles to the south of the pass. What had caused them? What could cause the one he had just witnessed? Even now he found it incredible to believe what he had seen.

He looked over the coaming. Yes, there was Bloor, still soaring like a winging eagle, making use of every second to try to reach the tarmac. What pictures he must have of what lay beyond Suicide Pass!

Then it happened again. One second, Bloor's crate was a flying Camel, and the next, it was an unheld torch. A flaming brand, it smeared across the sky, rolling and tumbling until it exploded.

"God!" breathed Boomerang in awe. He felt Thompson's hand upon his shoulder, and twisted about.

"Let's get out of here," Thompson shouted. "It's two to one now, and we can't save them, anyway. Maybe we'll get the same. Besides," he added, tapping his camera, "I've got pictures of those crates just as they went up."

"Pictures? Of those flames?"

"Yeah!"

"Good work, Thompson—great work!"

And the honest enthusiasm behind the remark again caused Thompson to relax his hostility. "Come on, let's kite it," Thompson again urged. He drew a breath to add something—but it was never uttered.

Burning down upon him from above, partly hidden in the brewing clouds and storm, the fighting fool in the red Fokker unleashed a hail of lead. A tracer smashed into Thompson's chin, dissolving it like a powerful chemical. A second disappeared into his head. A gasp of surprise was stopped only by death, as he slid forward into his pit, limp and inert.

Boomerang jerked his stick back. The Spad shot like a lumbering ox toward a cloud pocket. The powerful Hisso roared under the gun.

He had to get into those clouds. There were pictures in that camera that must be returned to the 39th Observation Unit. These were the pictures that might solve the mystery of those many fires—pictures that would be a monument to Thompson's memory.

Never in his life had it been so urgent that he return to the tarmac. Behind him, the red Fokker's Spandaus kept up an incessant chatter. On and on he winged. A slug creased his helmet, but he scarcely noticed it. Nearer and nearer crept the clouds. Another tracer slugged him on the helmet, but it was a glancing blow.

"I'll hunt that Boche up some time," he muttered to himself through thin lips turned grimly down . . .

BOOMERANG brought his Spad to a halt before the large hangars of the 39th Observation Unit and jumped to the ground. Somewhere in the maze of buildings that was the 39th, a tin-pan piano crashed a noisy trot, an octave off tune, while from the hangars came a raucous call.

"That boomerangin' guy is back, but it looks like Thompson has been hurt or—" The voice died away.

Boomerang grimaced at the thought of what Sergeant Wilson was going to say when he learned of Thompson's end.

He turned and remounted the Spad again, where he lifted the inert form of Thompson from its straps, swung it to his powerful shoulder, and dropped clumsily to the ground with it. Taking a limping step away from the Spad, he placed the body on the ground with incredible gentleness.

Blood-smeared now, he stood above the dead figure, wiping the sweat from his face with the back of his hand and arm. A siren blared forth, and the tin-pan piano died with its first blast.

Men swarmed the tarmac from all directions, and Boomerang watched their movements. Among them ap-

peared a white-haired official. His face was unusually pale.

"You hurt, colonel?" the white-haired man asked.

"No, Major Ayres," Boomerang replied, his eyes cupped in dark shadows. "But get Fisher working on those plates. Thompson took them—and maybe they're important."

"Suicide Pass?" demanded the C.O., while a ray of hope suddenly lighted his eyes.

"No," Boomerang replied, "pictures of Bloor's and Abbott's blazes."

Despair again swept over the C.O. He motioned Fisher into action. His eyes became more sunken as he turned and moved toward his quarters like a man in a daze. Boomerang was puzzled. What had happened that he didn't know about? He turned to follow the C. O., fearing his knees would buckle beneath him.

Boomerang's lame foot swung in an ungainly motion, but he had taken less than five steps when a firm hand grasped him on the shoulder. He turned to find himself gazing into the blazing eyes of Sergeant Wilson.

"You're a colonel, and I'm not supposed to tell you what I think of you," Wilson chopped off in biting words. "You're a cripple, so I can't slap you silly." His voice was filled with bitter contempt. "You're well protected. But if—"

Boomerang shrugged easily. "But speaking man to man," he broke in in a low, even breath, "you'd like to say and do—just what?"

"Call you a rotter, and knock you flat!" Wilson flared.

Nor did Wilson stop at words. His fist lashed out in a terrific swing. It started somewhere near the ground and ended flush on Boomerang's jaw. Boomerang catapulted from those knuckles a dozen paces, dazed and stunned. But he kept his feet.

Like a wounded tiger, he bounded back upon Wilson. Wilson smashed flush into his face and above his eyes, but he drove in as though life depended upon it.

In spite of his game leg, Boomerang shifted with uncanny ease. He was everywhere at once. His fists shot out like bolts. They thumped and clubbed and pounded.

And then he saw an opening—just a small opening, but it was enough. Crash! What might have been an arm, but behaved like a battering ram, plunged elbow-deep into Wilson's stomach. Wilson dropped.

Three other men made menacing moves, as though they wanted to take up the fight where Wilson left off. Boomerang was not popular. Anyone who was after the Old Man's post was bound to be extremely unpopular. But Wilson held up a cautioning hand.

"Leave him alone, fellows," he panted. "I'm not through yet. When I get my wind—"

"When you get your wind," snapped Boomerang sharply, "you'll fix that crate of mine for another flight. And don't be long getting your wind, either. I'm going over Suicide Pass for a little

detail work right away."

Detail work? That meant observation, photographs. And no man who had gone over Suicide Pass for photographs had ever returned.

A taunting laugh rolled from Wilson's lips. "That means your boomeranging days are at an end," he said. "You're about to take a patrol from where there's no return, even for a boomerang pilot like you."

"Wilson, cut that out!" Fisher's sharp features were pushed forward. He laid a steadying hand upon Wilson's shoulders. "That sounds like a threat. And if anything should happen to him—"

For a second, Boomerang gazed at Fisher. His boring eyes were suddenly lost under heavy brows. Then he shrugged and turned from the scene.

INSIDE the C. O.'s quarters, gloomy oppression seemed to have settled about the dark gray walls. Boomerang stalked in without knocking. His clubbed foot thumped irritatingly upon the uncarpeted rough boards. Major Ayres scarcely glanced up from where he sat, his chin upon his chest. His face was still white, even whiter than before, and his hands trembled as though he had chills. Before him, a large official foolscap lay partly folded.

"Bloor is gone now. Abbott, too." He spoke in a dull monotone. "The last, and the best. The squadron is through. And it looks as if you were right when you told G.H.Q. not to send me here.

"At six o'clock—fifty-three minutes from now—our boys will be on the loose. They are supposed to take Suicide Pass, and the Germans aren't even going to try to stop them. Why? Because something fiendish is behind Suicide Pass. Abbott and Bloor probably knew what devil's trap was laid there. If they had returned, ten thousand lives would probably be saved. But as it is, this squadron has failed in the most important mission it ever had. I shouldn't have been sent here to command. You were right . . ."

Boomerang turned and stalked to the door. He had heard a noise outside. He flung it open and faced Fisher. In the chemist's hands were two dripping films. Boomerang took them wordlessly, and closed the door. Turning toward the C.O., he gazed at the films.

"Hummmmm," he muttered tonelessly. "Nothing unusual here. Just two crates. Abbott's and Bloor's. Flames starting just ahead of the front pit." He passed them to Major Ayres. "What do you make of them?"

The C.O. frowned as he squinted over them. Finally, he looked up, his face a blank. "Not a thing. Just crates on fire. And you?"

Boomerang's grim eyes suddenly blazed. "Plenty!" he said. "Plenty—but still not enough!" He glanced at his watch. The fifty-three minutes were now fifty-one. He had fifty-one minutes to save ten thousand lives from destruction. "In fifty-one minutes I'll know the rest!"

Outside again, Boomerang found that a bitter drizzle had set in. A raw, bit-

SELLEY'S CHRISTMAS SPECIALS

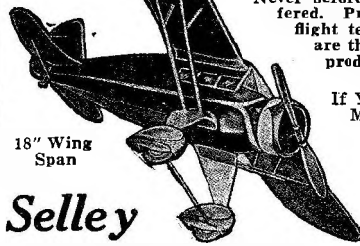
AFTER ALL THERE IS NO SUBSTITUTE FOR QUALITY

Never before have such values been offered. Professionally designed and flight tested for performance, these are the best flyers Selley has ever produced and at such a low price.

GUARANTEE
If You Are Not Satisfied, Your Money Will Be Refunded.

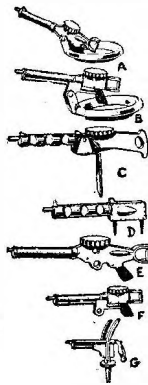
These new models are sensational in their flight performance. Flights over 300 feet are GUARANTEED with these snappy, LARGE, long-distance flyers.

STINSON RELIANT



18" Wing Span

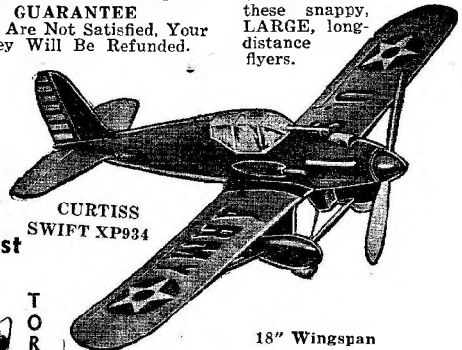
Selley ACCESSORIES



New Guns Die Cast

- WITH RING MOUNT**
 1 1/4" long B 25c
 1 1/2" long A 30c
SWIVEL TYPE GUNS C
 2" Double Action . . . 15c
PURSUIT TYPE GUNS D
 3/4" long5c
 1" long5c
 1 1/2" long5c
TYPE F
 1 1/4" long10c
TYPE E
 1 1/4" long15c
DUMMY RATCHET GUN
 7/8" long10c
 Postage 3c each

- Bombs and TORPEDOES**
 13/16"5c
 1 1/4"10c
 3" Torpedo15c
DUMMY MOTORS
 Something New
 1" dia. 9 cyl. 30c
 1 1/2" dia. 9 cyl. 50c
 Postage 3c each



CURTISS SWIFT XP934

18" Wingspan

EACH KIT COMPLETE WITH FINISHED SAW-CUT PROPELLER

- Knife Cut Balsa Music Wire
 Printed Balsa Celluloid
 Ribs and Bulkheads Cement
 Colored Insignia Rubber
 Colored Jan Tissue Bamboo
 Wing Adhesive Red
- 50c** Each
 POSTAGE 10c

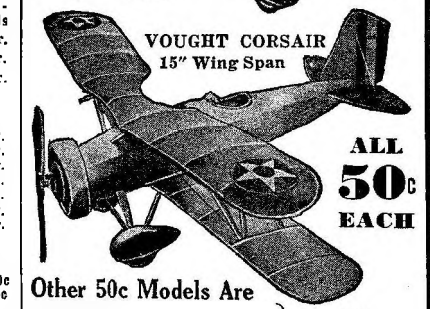
Send For Yours NOW!



HOWARD RACER "PETE" 18" Wing Span



HAWK P-6-E 15" Wing Span



VOUGHT CORSAIR 15" Wing Span

ALL 50c EACH

Other 50c Models Are

- Puss Moth } 18" Wing-span
 Boeing Transport }
 Bat—Swallow—Sportster }
 Boeing P-12 } 15" Wingspan
 Lockheed Sirius }

Kits from 25c to \$7.00

Send 5c postage for Catalog
 IMPORTANT. Minimum order 50c. Add postage on all items but if over 15c on less than \$1.50 order add only 15c. Orders over \$1.50 add 10%; west of Denver 15%.

PROPELLERS

Hawk Type		Standard	
2-Bladed	3-Bladed	2-Bladed	3-Bladed
3 3/4"25c	4"35c	1 1/2"10c	1 3/4"10c
4 1/4"35c	4 1/2"45c	2 1/2"15c	2 3/4"15c
5"35c	5"50c	3 1/4"20c	3 1/2"20c
5 1/2"40c	5 1/2"60c	4"25c	4 1/4"25c
6 1/4"40c	6 1/4"75c	4 1/2"25c	4 3/4"30c
7"55c	7"80c	5"30c	5 1/4"40c
		5 1/2"35c	5 3/4"45c
		6"40c	6 1/4"60c
		6 1/2"45c	6 3/4"50c
		6 3/4"50c	

Propellers can be had in Alum. Alloy Castings up to 12"—Larger sizes are finished up to 24" diameters. Send for catalog. Postage 3c ea.

Adjustable Pitch Aluminum Propeller

Suitable for Flying Models
 2-Bladed 8" dia. 35c
 3-Bladed with Shaft 9" dia. \$1.00
 10" dia. 50c 11" dia. 1.25

Special Shaft & Hanger
 Threaded shaft with soldered arc flange . . . 20c
 Postage 3c each

RUBBER TIRED WHEELS

Aluminum Disc Rubber Tired Tail Wheels	Aluminum Disc Rubber Tired Air Wheels
1/2" dia.5c ea.	1" dia.18c pr.
3/8" dia.6c ea.	1 1/4" dia.20c pr.
3/4" dia.7c ea.	1 1/2" dia.25c pr.
7/8" dia.8c ea.	
1" dia.9c ea.	Treaded Rubber Aluminum Disc
1 1/4" dia.10c ea.	1 3/16" dia.30c pr.
1 1/2" dia.11c ea.	1 1/2" dia.40c pr.
	2" dia.50c pr.
	3" dia.60c pr.
	5 3/8" dia. . . . \$1.25 pr.
	6 1/2" dia. . . . \$2.00 pr.
	7" dia. . . . \$2.50 pr.

SEND FOR CATALOG

Balloon Tire Alum. Disc
 1 1/2" dia.25c pr.
 1 3/4" dia.28c pr.
 2" dia.30c pr.

Bat Tired Cel. Disc Wheel
 1 1/2" dia.30c pr.
 1 3/4" dia.33c pr.
 2" dia.35c pr.

Swivel Joint Fork and Axle
 1/2 up to 5/8" wheel 10c
 3/4 up to 7/8" wheel 15c

Postage on Rubber Tired Wheels, 4c

Spun Aluminum COWLS

Dia.	Drag Ring	Open Face	Closed Face
1"	15	15	15
1 1/2"	20	20	20
3"	28	28	28

Postage 6c

PICTURES ON BRISTOL BOARD

2 1/4" x 4 1/4" of AUTHENTIC AIRPLANES

24 ARMY25c Set
18 NAVY25c Set
16 WARTIME25c Set
84 SQUADRON INSIGNIA25c Set

Postage 3c set

SELLEY MFG. CO., INC., Dept. 101, 1377 Gates Ave., Brooklyn, N.Y.

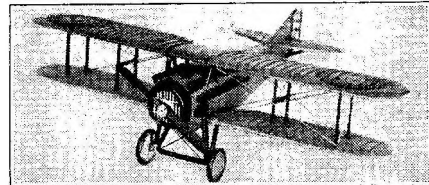
YOUR FIRST STEP IN REAL AVIATION

IS THE BUILDING OF
AUTHENTIC MODEL PLANES
AIRCRAFT HAS THEM
PILOTS! PROPELLERS! MACHINE GUNS!
ALL DIE CAST

THE MOST AUTHENTIC LINE OF 1/4" TO THE
FOOT SOLID SCALE MODELS EVER OFFERED



SOPWITH CAMEL



SPAD XIII



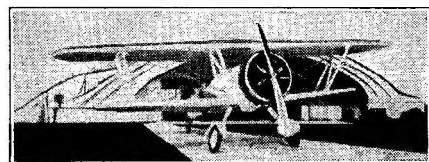
S.E.5



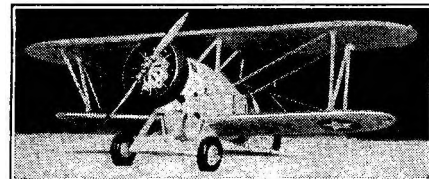
FOKKER TRIPE



ALBATROSS



CURTISS GOSHAWK



BOEING F4B4

The above are actual photos of MODELS

35 cents each 3 for \$1.00

Single kits add 5 cents postage. In lots of two or more, we pay postage. CANADA, 10c EXTRA. Add 10 cents to cover cost of exchange on personal checks.
Spad XIII Nieuport XVII Fokker Triplane
Fokker D VII Sop. Camel Curtiss Goshawk
S.E.5 New Monocoupe Albatross D5
Waco Model "A" Fokker DVIII E/I P85
Boeing F4B4 Boeing P26A

EACH KIT CONTAINS:
Liberal portions of colored lacquers and cement, finished pine wheels, colored insignias, rigging wires, most difficult parts cut to outline shape, detailed drawings, etc. The greatest value ever offered at any price.
EASILY ASSEMBLED. SIMPLIFIED CONSTRUCTION. WORLD FAMOUS PLANES.

CHRISTMAS SPECIAL Any 7 Kits \$2.00

AIRCRAFT 4911A Cornell Ave. OHIO ACO. I. I.

ing wind swept the flats where, a hundred yards from the farthest hangar, four men were putting Thompson to rest. The soft thuck, thuck of the wet earth on the pine box reached his ears, and his face steeled under a wave of hate.

At the deadline, his Spad was already prepared for the flight. Limping toward it, he came upon Wilson, and their eyes clashed.

"I don't think you'll find returning so easy from Suicide Pass," Wilson breathed.

Boomerang grunted. "What's one man's opinion?" he asked.

"More than you think, boomerang pilot!" Wilson muttered. "Much more than you think."

Boomerang eyed him sharply. But his mind was on those two dripping films that pictured flames licking out from behind the motor. Faintly, too, they had showed a dark spot in the top of the cowling. And the dark spot—was a hole, the unknown, like the "X" of algebra. He looked at his watch. In forty-eight minutes he would know the answer.

And the question jumped to his mind like a glaring sign: "Will I be able to return with the answer? Will I boomerang this time?" And for once he had his doubts.

The forty-eight minutes were now forty-two. He was gunning high in the heavy clouds. The Spad soared like a scouting eagle. It grew darker. The mist had long since turned into a drenching rain, a rain that lashed his face cruelly.

More minutes sped, and ahead reared the gaunt crags of Suicide Pass. Hills 604 and 319, they were called on the maps. Below him now swept the spot where Bloor had gone to his fiery bed. The hills grew nearer. Hills 604 and 319—Suicide Pass. And now he had only twenty minutes left to see what awaited ten thousand men behind those hills.

The hills were beside and below him. The sheer gorge, through which ten thousand men would flood, lay beneath him, gaunt and gray. His eyes strained downward, and saw only sandy, shell-strewn flats that had once been a river bed.

Then suddenly his eyes opened wide. He had sighted something to his right, something large and heavy which stretched for half a mile across the river bed like a mass of concrete reinforcements for a fort. He breathed an audible gasp.

Quickly, he kicked left rudder and banked toward it. Outlined against the blood-black horizon, the massive steel-colored wall grew larger and more ominous. Could this be the mystery that had lured so many men to their deaths? Was it luring him? His throat grew dry.

As he drew nearer, the huge wall took no more shape than it had at first. It was just a wall stretched across the valley. Surely this was no fort. It hadn't the width, and it was much too high. It would be a shining mark for field mortars.

His eyes opened wider, startled.

Something was glistening in the murky blackness beyond the walls. He frowned, pushed his stick forward, nosing down.

Then his eyes opened in horror. "Damn it, it's impossible!" he roared to the empty sky. But he knew it wasn't. He had discovered the terrible secret behind Suicide Pass.

Water!

ACRES wide, miles long, tens of feet deep was the flood-bed. Water by the millions of tons, by the billions of gallons, gleamed there—water waiting to smother the lives of ten thousand men. And the vast force was held in check only by those thin, ribbon-like walls of steel and concrete.

He looked at his strap watch. It was twelve minutes to six. He had twelve minutes before ten thousand men would rush that pass—Suicide Pass! No one could stop them now.

Something else caught his eye. Massive, lumbering trucks were winding toward the dam and starting slowly across it. On the far side, a road led to the mouth of the pass, where huge pockets were formed in the slopes.

Those trucks carried munitions. Already the Germans had learned of the intended push. When the last man had passed through Suicide Pass, those trucks would blow the only escape to kingdom come. Then the dam would go, loosing a mountain of water on the trapped victims.

Above him now, something gray and ominous roared. Darting tracer runners lanced the black clouds. Boomerang threw a glance ceilingward.

"The Fokker tripe!" he breathed through pressed lips. It was the fierce fighter of the afternoon.

As the first lead struck his crate, Boomerang threw his stick forward. Down he went, his face grim. He looked over his shoulder. The German was directly above. Then he jerked his stick back. The Spad reared up, stood on its tail.

His Vickers yammered. Red and orange flame danced off the gun's black nose, and white tracers disappeared into the Fokker. The German pulled off, twisting up in an Immelman.

Boomerang glanced down and saw that below the trucks had already started across the ribbon of concrete. Fear seized him, fear that those trucks might get past.

"Damn it, never!" he exploded, and threw his stick forward.

Straight at the first truck he gunned. Down, down. His Vickers yammered. Explode one of those trucks, and that dam would be blown to powder. Straight at the trucks, he dived, his gun lined on the gray-green canvas. Hairy streamers disappeared into it, and between those hairy lines were incendiaries. But the truck failed to explode.

A clammy sweat suddenly filmed his body. Why hadn't that truck exploded? He was puzzled.

Crash! Something smashed through his coaming, and his motor emitted a raucous whistle. Startled and bewildered, he jerked his hand in a sudden jump toward the switch to throw it

off. Something had happened to the motor. But on the switch his hand froze.

He looked at the cowling. There was a hole in it the size of a fist—a hole torn from the inside, because the ragged ends were pointing out. And slowly—very slowly—his hand left the switch. The motor was still running.

Now he knew what had caused Abbott's death and Bloor's and twenty-odd others. Now he knew what he had come to the 39th Observation Unit to find out.

A spark plug had killed each of those men! Before each flight, a spark plug had been loosened. During the flight it had worked its way free. When it left the motor, it smashed its way through the cowling. The crash had startled the pilots, and spontaneously they had reached to shut off their switches.

Then had come the end. The gas had not drained from the carburetors. The motors had backfired, as was inevitable, unless they were emptied of gas—and the fires had started. It was simple, hideously simple. And only some one on the 39th's tarmac was capable of the hellish act.

Boomerang Conners was jerked from his trance by a fiery burn that guttered his scalp. Warm blood slid down his neck. With lightning swiftness, he stood the Spad on its wings and banked about. Straight up at the Boche ace he gunned. Again the feathery lines of the tracers penciled the sky. And again the German climbed.

Boomerang instantly threw his crate into a crazy plunge. Down upon the leading ammo truck he hurtled. His

Vickers lashed and jerked. Blast after blast he sank into the canvassed top of the lumbering truck, but still without setting it off. Could it be that the truck didn't have munitions, after all? No! Of that he was certain.

Crash! Another hole appeared in the cowling. The weird whistle now became a howl. The crate hesitated. With two cylinders dead the motor's strength was greatly diminished. It was forced to its limit to carry the Spad on an even keel.

"That Boche back at the 39th wasn't taking any chances on my boomerang-ing back this trip," he muttered with a grimace. And now he remembered Wilson's words: "I don't think you'll find returning from Suicide Pass so easy."

Again the Fokker was upon him, trying to keep him away from those trucks. Boomerang's hard face knotted. He jerked his stick back. The Spad wobbled upward in a lumbering climb. His Hisso screamed under the gun.

Straight at each other those eagles hurtled now—the German down, the Yankee up. Twice the Hisso with its dead cylinders almost failed. And twice Boomerang had to cut his climb to save it. Each cut was an advantage the German was quick to grasp.

Boomerang threw his crate into a loop to gather speed. As it rounded out, he hung the plane on its wings. Over his shoulder he could see the Fokker gunning down. The Spad fanned about. Brrrrrrr! The crosswires of the Vickers climbed on the Fokker. A lance of them struck the fuselage.

Then came flames—first a little

XMAS GIFTS
DESIGNED BY TROPICAL
The perfect present for your pal, son or daughter



FX-9—BOEING P-12E 50c Postpaid

THIS KIT CONTAINS: Full sized simple plans with instructions; Clearly-printed bals; Large bottles of cement and dope; Colored dyes; Colored Jap. tissue; Prop block; Turned wheels; Formed wire fittings; Washers; Eyelet; Bals; Pins; Reed; Insulin; Wax paper and sand paper; Actual detailed photograph of complete model built from this kit.

9" Solid Models 3 for 95¢ p.p.
35c each or 3 for 95c p.p.



SS-3 SIKORSKY S-41

These kits contain full size plans and instructions, clearly-printed wings, tail surfaces and parts on CORRECT thickness wood for proper shape. Wheels, dope, cement, and sandpaper.

Other 9" Solid Models

SS-1—SPRINGFIELD RACER	SS-4—W. DELL-WILLIAMS RACER
SS-2—VOUGHT-CORSAIR V-80	SS-5—LOCKHEED ORION
SS-3—SIKORSKY S-41	SS-6—CURTISS SPARROW-HAWK

CASH AT OWN RISK—NO STAMPS—MONEY ORDERS TO

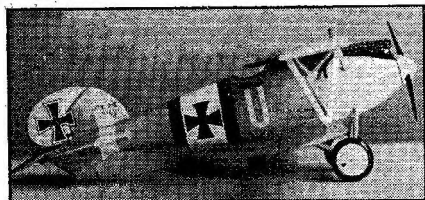
TROPICAL MODEL AIRPLANE CO.
175 N.W. 31st STREET, MIAMI, FLORIDA

Authentic Scale Models are Built from

PGH. SCALE MODEL KITS because—

1. ACCURATE 3-view drawings (full size).
2. SEPARATE SHEET of construction drawings, contains step by step assembly, sketches of guns, motors, moveable controls, etc.
3. TWO LARGE PHOTOS—A FRONT AND REAR VIEW for detail.
4. ALL WINGS stamped and semi-cut to outline size. Strut places even marked on most wings. Takes the guess work out of assembling.
5. ALL PARTS—tail, wheel plane, rudder and axles printed on bals.
6. ACCURATE SMOOTH SANDED BODY. Side view cut to shape. Leaves only top view tracing and finishing.
7. ROTARY ENGINED ships have a READY TURNED COWL which allows a MOVEABLE ROTARY MOTOR TO BE MADE AND INSTALLED.
8. EVERY KIT contains 4 or more bottles of GLOSS ENAMEL PAINTS which is applied over WOOD FILLER.
9. WOOD FILLER—A SPECIAL PREPARATION WHICH WE ORIGINATED THAT GIVES EACH PLANE A GLOSS FINISH.
10. A STAMPED prop—easily carved, also turned wheels.
11. INSIGNIA, in full authentic rich colors—French, British and German.
12. ROUGH, MEDIUM AND FINE SANDPAPER for finishing model.
13. DASHBOARD, WINDSHIELD, wheel pins and paint brush.

The Wood Filler in These Kits Approved by the Junior Birdman Institute, Serial No. 6



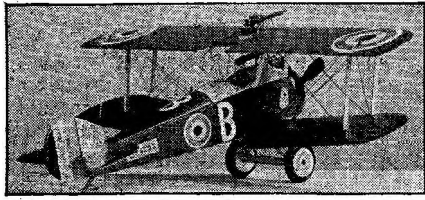
Span 12 3/4", **ALBATROS D-5** length 10 1/2".
Colored all blue, black and white trim.



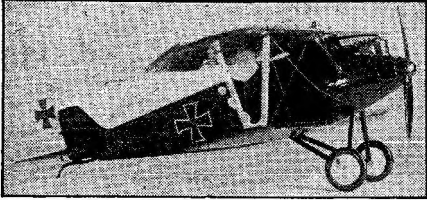
Span 11 1/2", **NIEUPORT 27 C-1** length 7 1/2".
Colored all yellow, brown trim.



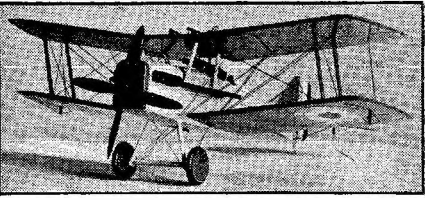
Span 11", **FOKKER TRIPE** length 8 1/4".
Colored all red, white trim.



Span 12", **SOPWITH "CAMEL"** length 8".
Cream color underneath, olive drab on top.



Span 13 1/2", **PFALZ D-3** length 10 1/2".
Colored green wings, red body.



Span 11 1/2", **McCUDDEN'S S.E.5.A.** length 9".
Colored with yellow wings and blue fuselage.

EACH MODEL WHEN FINISHED IS GUARANTEED TO HAVE A HIGH GLOSS FINISH

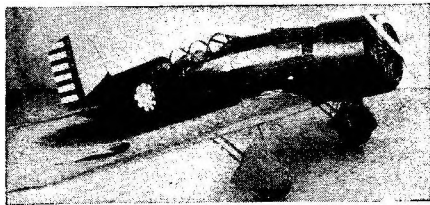
EACH KIT COMPLETE IS **\$1.25** POSTAGE PAID

How to Order

Send M. O. or Check, cash at own risk. Canadians use International M. O.

PGH. SCALE MODEL AIRPLANE & SUPPLY CO.
635 Penn Avenue, Dept. F-1, Pittsburgh, Pa.

— — THEY ADVERTISE — LET'S PATRONIZE — —

Lockheed P23 Army Pursuit

32" Span, Length 23 1/2", Weight 3 1/2 oz.
Combination Land and Seaplane Set

Set includes all parts printed on balsa wood, turned cowl front, balloon celluloid wheels, color yellow and drab, large 53"x44" drawing, printed wood for pontoons, wire prop, etc. Const. Set, Postpaid **\$2.95**

New Curtiss Hawk P6E

24" Span, Flies 800 feet.

All parts printed on balsa, colored dopes, glue, drawing, etc. Set postpaid **\$2.50**

New Curtiss XP934 Army

24" Span, Flies 675 feet.

Set has all printed parts, colored dopes, drawing, glue, wheels, etc. Set postpaid **\$1.75**

Northrop FT1 Navy Fighter

22" Span, Weight 2 oz. Color, silver.

Exact scale flying model of latest 275 M.P.H. U.S. Navy fighter. All parts printed on balsa, turned cowl front, aluminum wheels, fibre prop, silver dope, glue, insignia, drawing, etc. Const. Set, Postpaid **\$2.00**

Send 3c stamp for illustrated catalog

MINIATURE AIRCRAFT CORP.

83 Low Terrace

New Brighton, N. Y.



Your Choice of
**Stinson Reliant
Monocoupe-Warner 110
Heath Parasol**

**Giant
Flying
Models**

Each **\$1.50** Each
for Postpaid

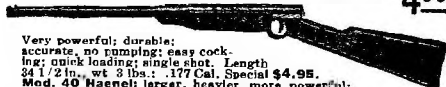
Each in Complete Kit with full size 5 ft. Plan, all Materials, cement, dope, rubber, insignias, etc., and semi-finished propeller; sent postpaid for only \$1.50
Same Kit, with fully-finished, 15 in. Paulownia Wood Propeller (Value 75c.) sent postpaid for only \$2.00

Send 6c for New Catalogue.

INTERNATIONAL MODELS CO.
1783 Broadway, New York, N. Y.

FREE

with your order.
New Catalogue
with Hints for
Model Builders,
also IMP Club
Pin.

HAENEL MODEL XV AIR RIFLE \$4.95

Very powerful; durable; accurate, no rumping; easy cocking; quick loading; single shot. Length 24 1/2 in., wt 3 lbs.; .177 Cal. Special \$4.95.
Mod. 40 Weaver larger, heavier, more powerful; rifled barrel; pistol grip; (Regular \$5) Special \$6.95.
Darts 25c doz., 500 Rubbed Pellets 75c; BB Shot 25c.
Remington No. 6 Imp. 22 and .22 cal. Rifles; long or short r. f.; 20 in. barrel; take down. (Regular \$8) Special \$4.95.
Hunting Knife; genuine deerfoot; 6 inch steel; Special \$1.25.
Telescope: 40x, 3 ft. Giant 10 mile; fibre, brass trim \$1.65.
Microscope: 125x Complete Ocular, nicely boxed 12x12 in. \$2.49.
All Depots on C.O.D.'s. Catalog: Firearms, Micro and Telescopes; Air Pistols and Rifles, etc. Send 3c Stamp.

LEE SALES CO. (Dept. FA12) 38 West 32nd St., New York

patch of them, then a great pyre. A mighty blaze filled the sky, lit it momentarily and then disappeared into the waves below.

A GLANCE at his watch told Boomerang that the boys were already nearing Suicide Pass. He looked down. The first of the trucks was already safely over the dam. The second was almost so. Only the third remained. Down he went after it, his eyes glued on the crosswires of the Vickers before him. The whole Spad seemed to spin on the nose of that gun. Tracers and incendiaries cut their way through the canvas roof of the truck. Tens, twenties and hundreds of them—but the truck rolled on and on. Not a tracer or incendiary was capable of setting it off.

Desperate, sweating with the fear that he had failed, Boomerang pulled the Spad off the canvas of the truck. The weakened motor strained under the climb. His brain was a maelstrom of rioting thoughts, then one came clear and he stiffened.

"Sand!" he screamed aloud. "Sand! They've bedded that ammo in bags of sand!"

Instantly he knew that his Vickers would be powerless. Nothing less than a shell could set that truck off. He cursed himself for a fool.

His face grew grim and determined now. He threw the throttle full ahead. The undercarriage of the crate almost touched the water. He kept it as low as was safe, and gunned straight at the cab of the truck. Then his Vickers cut loose.

Rat-tat-tat! A Maxim on the truck yammered now, but still he gunned in, nearer and nearer. The driver of the truck screamed. Boomerang laughed insanely.

"Scream, you Kraut, scream!" he roared. "Jump for your hide or I'll pile this coffin right in that cab!"

The German seemed to sense that he faced a maniac—a man whose eyes blazed with only one purpose. He held on until the last minute, then jumped as a tracer burned him down. The truck swerved violently, lurched, rolled to the edge of the parapet and tottered. For a breathless second it hung there. Then over it tumbled—down and down.

A muffled explosion rocked the earth. A wall of varicolored fire splashed against the bleak wall. Then steel and concrete and bursting sandbags filled the air. The flare of crimson lit the skies, turning darkness into day. The Spad was hurled into the clouds, where it tumbled and rolled.

Boomerang fought the controls. Something heavy struck him in the face, dazed him, blinded him. Desperately, he shook off the coma that tried to engulf him.

Crash! Another plug left his Hisso.

The Spad lurched dizzily, and the sudden dip brought Boomerang from his sickening coma.

"I must get back," he told himself grimly. "I must get back!"

He looked below. All was quiet now. But there was no earth. Only water was everywhere. Torrents of it boiled and

milled, carrying everything before it.

As he pulled his crate toward Suicide Pass, he saw the advance men climbing the steep sides to escape. There were no dead bodies to be seen anywhere. Boomerang's brain suddenly felt lighter.

"But I've still got to boomerang back to that squadron," he told himself. "The greatest boomerang of them all. . ."

IT was inky black when Boomerang Connors' Spad cracked up outside the hangars of the 39th. The crate had come in tail-heavy, its motor screaming like a siren, and its pilot dizzy from loss of blood. A splintering landing had been unavoidable.

Boomerang crawled from the wreck, weak and sick. He was barely able to gain his feet. It was the helping hand of the ill-at-ease Sergeant Wilson who finally gave him the necessary impetus.

"Always a boomerang," Wilson lamented in grating tones. "You can even come back from Suicide Pass. It's a damn shame that such a good pilot has to be a skunk at heart."

Boomerang ignored the insult.

To Wilson, the return of Boomerang Connors could mean only the final downfall of Major Ayres. Boomerang had succeeded where all the men under Major Ayres had failed. He had gone out and returned, where twenty-five other men had gone to their graves.

Across the blackened shadows of the hangars, a figure darted. It moved with canine speed. Instantly, Boomerang summoned his remaining energy to the surface. He snapped a command.

"Stop!"

The figure turned, a snarl on his lips. A shot rang out. A stinging blow on the shoulder spun Boomerang half around, but he kept moving forward.

Another shot sounded, then a guttural moan. The figure ahead slumped to the ground. Boomerang reached him, followed by Wilson. Wilson struck a match, and by its flickering flame he could see the blood-drenched face of Lieutenant Fisher. And with that same glance he saw that Boomerang had no gun.

A puzzled expression spread across his face. It brought a pleased grin to Boomerang's tired eyes.

"That's number twenty-six, Wilson—and the last," he said, quietly. "He did it himself, just as he did it to the other twenty-five."

Wilson frowned. "What are you talking about?" he asked. "Have you gone haywire?"

"Look at that motor of mine when you go out," Boomerang explained. "That will show you what Fisher did. He loosened those plugs just enough to let them work free. You know what you'd do if it suddenly sounded as if half your motor was coming through the cowlings."

"Shut it off," said Wilson, still puzzled.

"Exactly. That's what Bloor, Abbott, Chess and all the rest did. And—"

"Backfire," breathed Wilson. "He—why, that—" He suddenly jumped toward the inert form, but Boomerang

jerked him back with a cautioning hand.

"None of that, Wilson," he ordered, sharply. "He didn't do a thing for his country that we wouldn't do for ours. Why, you and Thompson were ready to murder me because you liked a C.O.!"

Wilson was silent. The flickering match had long since gone out. Everything was black. Fog and rain swept into the mouth of the open hangar. The reeking smell of petrol and oil filled the air.

Finally, Wilson broke the dank stillness. "How did you know it was—him?" There was still contempt in his voice.

"I didn't, at first," Boomerang confessed. "I thought it might be Thompson. But when I took him up today and he jammed a Colt in my neck to make me save—or attempt to save—Bloor and Abbott, I knew it couldn't be Thompson."

"But why did Fisher fix your crate on the second flight today, and not on the first?" demanded Wilson.

"Because I was going over Suicide Pass on the second flight. I was not going over it on the first. And he was interested only in keeping pilots from returning from Suicide Pass. You played almost into his hands, too."

"I?" gasped Wilson.

"You said I would never return from Suicide Pass—and that was an opportunity for Fisher to tell you not to threaten me. If anything happened to

me, he could easily have made a court-martial board believe you did the work. But when I saw him move in the dark and called to him, he knew his trick was up—and tried to kill me. Then he killed himself—for the Fatherland."

Silence followed. Wilson's heavy breathing accentuated it sharply. Then from the darkness came an old voice.

"At least I'll surrender my post to a much better man," it said.

Boomerang and Wilson turned about sharply. Only the white hair of the aged C.O. was visible in the blackness. They gazed upon him, and Wilson uttered a choking sound.

"Surrender your post?" demanded Boomerang. "To whom?"

"To you, of course," Major Ayres replied, his voice breaking. "You were right when you told G.H.Q. I wasn't capable of commanding this squadron."

"I didn't come up here to take your post, major," Boomerang said sharply. "What I did come up here for was to find out about those fires. Moreover, I'll never again say a man is too old to command a squadron. I was dead wrong in your case, and G.H.Q. will find that out from me. Any man who can get his men behind him so they are ready to murder a colonel for him—well, he's all right."

Major Ayres was wordless. Only the gigantic Wilson had strength to move. He reached forward and grasped Boomerang's big paw.

Boomerang grinned, broke free and gave both men a friendly nod. "Got to go find my pipe," he said. He swung away, still grinning, his awkward limp a little more pronounced.

The major cleared his throat. "Wait—er—Boomerang." He caught up with the limping figure. "I—I'd like to join you. I smoke a pipe, too."

Wilson watched them cross the tarmac, arm in arm.

HUB MODELS



24" U. S. MARINE FALCON
\$1.25 P. P.



24" FOKKER HOSPITAL SHIP
\$1.75 P. P.



24" BOEING P12E \$1.75 P.P.

Can't be beat for Quality and Price

For Model Builders who want the best. **Known Everywhere for Accuracy Completeness Performance**

All parts, including bulkheads, ribs, etc., clearly stamped on balsa formed wire parts. Insignia, full-size plans and instructions, everything to complete perfect, authentic flying models.

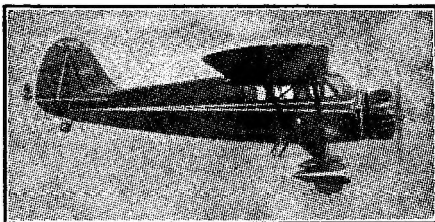
The two kits at \$1.75 each also contain (in addition to above) anti-drag rings, cowl plate and 9-cylinder motor. Complete in every detail.

Remit by check or M. O. Send 5c stamp for detailed price list

HUB MODEL AIRPLANE & SUPPLY CO.
475 A-1 Brook Ave., Bronx, N. Y.

VALUES • VALUE IS MEASURED NOT BY WHAT YOU PAY BUT BY WHAT YOU GET!

GOLD SEAL LINE 24" Models with Movable Controls from Cockpit

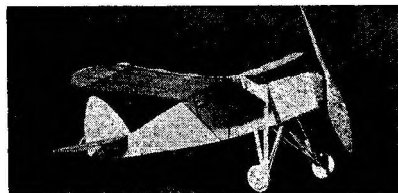


STINSON RELIANT

Modern and war time planes you will enjoy building. Control Wires are so designed that they will not interfere with your rubber motor. Kit contains all horns, pulleys, and hinges ready made, 3/4 finished wheel pants, two colors tissue, all parts printed on Balsa, aluminum spun cowl, finished propeller. Fully detailed plan and complete instructions, cement, dope, etc. Without doubt, the most elaborate Kits ever offered to the model builder. There are six models to choose from:

- | | | |
|--------------|-----------------|--------|
| Curtis Swift | Spad | \$1.15 |
| Douglass 038 | Albatross D 5A | |
| Hell Diver | Stinson Reliant | |
| | | |

DEALERS—Send for pricelist of the most complete model airplane line in the world. 75 different models from 10c to \$1.00.



20" COMMANDER

20" FLYING MODELS

Kit contains full size plans and instructions, all printed parts, cement, colored tissue, wire, rubber, wheels, strips, etc. Four models to choose from:

- | | |
|----------------------|-----|
| Heath Parasol | 60c |
| Curtiss Wright Coupe | |
| Verville Air Coach | |
| Commander | |

12" FLYING SCALE MODELS

Contains printed parts, wheels, cement, rubber, prop block, tissue, etc. 8 models to choose from:

- | | | |
|--------------------|-----------------|-----|
| P. T. Army Trainer | De Havilland | 15c |
| Hell Diver | Monocoupe | |
| Boeing Bomber | Arrow Sportster | |
| Spad | Gee Bee D | |

14" ALL Balsa R. O. G.

- | | |
|------------------------|-----|
| Sure Flyer | 20c |
| All parts cut to shape | |

CONSTRUCT-A-PLANE CO., INC.
158 Graham Avenue Dept. F-1 Brooklyn, N. Y.

FAIRCHILD 22



cement, etc. 8 models to choose from:
Fokker Triplane
Curtis Falcon
Niueport
Waco

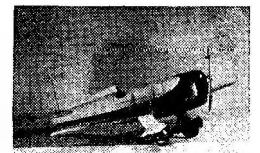
16" FLYING SCALE MODELS

Contains printed balsa parts, 2 colors tissue, wheels, wire, rubber, wood veneer, full size plan, dope,

- | | |
|------------|-----|
| Pokker D 1 | 30c |
| Goshawk | |
| Howard Ike | |
| Fairchild | |

12" SOLID REPLICA MODELS

With die-cast propeller. 2 bottles color, cement, printed balsa parts, etc. 10 models to choose from:
Douglass Spad
Gee Bee Aeronca
Fairchild 24
Bristol Fighter
Monocoupe



- | | |
|------------------|-----|
| GEE BEE | 30c |
| Boeing X P 936 | |
| Stinson Flamingo | |

"6 to 8" Solid Replica Models

21 models to choose from:

- | | | |
|--------------------|-----------------|-----|
| Gee Bee | Spad | 15c |
| Sikorsky Amphibian | Northrop Gamma | |
| Mystery S. Racer | Supermarine | |
| Fairchild 24 | S-E-5 | |
| Howard Racer | Pfalz | |
| Boeing P-12C | De Havilland IV | |
| Niueport 17 C-1 | Lockheed Vega | |
| Curtis Hawk P 6E | Hell Diver | |
| Savoia Marchetti | Waco | |
| Fokker D VII | Albatross | |
| Sopwith Triplane | | |

Boat Replica Models

4 models to choose from:

- | | | |
|-----------|-------|-----|
| Wanderer | TEXAS | 15c |
| Mayflower | Leary | |

SCIENTIFIC'S NEW "HI-FLYERS" No finer gifts for any model builder—these new, bigger, more durable and better HI-FLYERS. The choice of thousands of boys who want the best. Every kit complete—designed for perfect models.

25" DeLuxe HI-FLYERS \$1 EACH POST-PAID

GUARANTEED TO FLY 600 FEET

25" Vought Corsair, Model V80, \$1.00 postpaid
 25" Stearman, Model 81, \$1.00 postpaid
 25" New Monocoupe, Model 145, \$1.00 postpaid
 25" Great Lakes Sport Trainer, \$1.00 postpaid

New 20-pg. 1935 Catalog FREE: Send 3c stamp for postage. DEALERS: write for discounts

SCIENTIFIC MODEL AIRPLANE CO. 218-220 F1 Market St. Newark, New Jersey

Play A Tune In 10 Minutes

On your Spanish Guitar, Uke, Tenor Banjo, Mandolin or Banjo Mandolin. No knowledge of music necessary. No practice. Play first by number, then by note. Simply attach E-Z Player to your favorite instrument—press numbered keys and play.

FREE Instruction book with numbered tunes and chords comes with every E-Z Player. Start playing popular tunes by number, right off the reel. Be the life of the party—the center of attraction—a radio star. Don't wait. Write today for 3-Day Free Trial Offer and Special Guitar Values. A postcard will do.

FERRY SPECIALTIES, INC., Dept. 321 Evanston, Ill.

INVENTORS

Time counts in applying for patents. Don't risk delay in protecting your ideas. Send sketch or model for instructions or write for FREE book, "How to Obtain a Patent," and "Record of Invention" form. No charge for information on how to proceed. Communications strictly confidential. Prompt, careful, efficient service.

CLARENCE A. O'BRIEN
 REGISTERED PATENT ATTORNEY
 584-E Adams Building Washington, D. C.

5,000 M.P.H.'s an HOUR!
 will be flown by rocket planes in the near future. But now you can build a real flying model rocket plane from our specially prepared kit. You'll be proud to own and display this new and fascinating little masterpiece in your home.

Send for your kit today!
 Kit includes plan, instructions, all necessary material, stencils, two dope colors, etc., except string and glue.
 Price 60c postpaid (no stamps)

FERRY SPECIALTY CO., 196 East Broadway, New York, N. Y.

An Itch in Time

(Continued from page 14)

finger he tucked a tuft of red hair under his helmet.

"I know I look a fright, girls," he falsettoed. "Does my slip show, too?"

"I'm talking!" exploded Garrity. "If you weren't going to kick off any way, I would kill you myself. Go out an' unload those bombs where they'll do the most good—get it?"

"I couldn't do that, as that would be in Chaumont," grinned the incurable humorist as he climbed into his pit. "Well, wish us bomb voyage. Bump, I'll maybe see you at Oven No. 3 down in the big blast furnace. Adoo!"

"No more feelings than a landlord," mumbled Garrity as the two Spads, studded with bombs, zoomed toward the lines. "Well, er—what are you all choked up about, huh? This is war an'—"

"It ain't rainin'," Pilot Wilson tossed out, "so you must be sweatin'."

The C.O. swore, rubbed a thumb against his nose and headed for the farmhouse.

CONFLANS was a town guarded carefully by enemy crates. Anti-aircraft guns ringed it. It crawled with machine-gun nests. Against this array of mayhem, two Spads with six bombs were going to be stacked. It was like matching Jess Willard against Tom Thumb with hangnails. It was a cinch getting to Conflans. The catch was in the return trip. When Phineas arrived over the smokestacks of the town, he waved to Bump Gillis and then looked overside. He should have looked up. Four Heinies, whistling hymns of hate, piled down out of the sun.

Phineas caught the sound of machine guns chattering as he looked around for a place to drop an egg. The bomb dropped at random. A Fokker sliced by over his head. Another pecked at him from behind. Frantically Phineas let the bombs loose and looked for a way out. Anti-aircraft banged away. He envisioned Bump Gillis heading for home in a cluster of black pompoms. Two geysers of dirt and flame broke up below as Bump got rid of two tickets to eternity.

"This ain't my day," Phineas gulped and jammed in the throttle. He flew for two minutes before it dawned upon him that he was headed for the wrong goal line. Spread out fanwise behind and higher up were a trio of Heinies.

"I hope they have put improvements in the Heinie stockade." The venturesome Yank expressed the wish as he headed for the carpet. The landing field he chose was one that the other three Huns shunned. It was pocked with rocks and juniper bushes.

"Ach," a Jerry thrust out, "Dunkopf vhat he iss. Efen der goat it vould trip up, ja!"

Perhaps the Junker pilot did not realize who was landing the Spad. Phineas got the ship down, hopped a cluster of junipers, hit a rock and took off half a lower wing. The Spad seemed to curtsy like a young hopeful in front of

EXTRA Special Limited Offer to FLYING ACES Readers!

Here is good news for FLYING ACES readers! We don't want you to miss a single issue of the new, bigger, better FLYING ACES—the magazine that is a complete course in aviation in itself. We are therefore making this special offer of the next nine issues of FLYING ACES for \$1.00. These nine issues would cost you \$1.35 on the newsstands (and by getting there too late you might miss out on your copy), so by taking advantage of this offer immediately, you save 35c and make sure of getting this magazine, with its thrilling stories, interesting features, rare photographs and valuable data for your aviation scrapbooks, for the next nine months. Fill out the coupon below without delay.

This offer is good only in the United States and possessions

9 Issues (\$1.35 Value) for \$1.00

SUBSCRIPTION DEPARTMENT
 FLYING ACES MAGAZINE
 67 West 44th Street
 New York City

Gentlemen:

Please send me the next nine issues of FLYING ACES. I enclose herewith \$1.00.

Bill Check Money Order Stamps

Name

Street

City

State

(Print name and address clearly)

its grandma, then flipped over on its nose. Phineas, however, had left the crate before the nose dive.

He started running for a hiding place. Overhead the Fokkers circled with swearing Vons in their pits. Their would-be prey ran for a mile, spotted a hole in a bank and plunged in. He landed right in the lap of a burly unshaven German soldier who was roasting a chicken over a wood fire. Two other mean-looking Krauts were also within the crude dugout's interior.

"*Ein Yangkee!*" thundered a voice. "Joomp on him, *ja!*"

Effectively pinned down, Phineas looked up into the unshaven Heinie's face. Recognition brought a whoop from his mouth. The Jerry jumped back and cried, "*Himmel!*" Phineas Pingham iss idt, *nein?*"

"Haw-w-w-w!" laughed Phineas. "I'm among froids, *hein?* How are ya, Mister Schlosserheim? Remember when I put three cats in your refrigerator back in that butcher shop in Boone-town? Haw-w-w-w, an' the time I hung a rubber ham on the hook? What fun! But the best was when I put sawdust in your hamburger. Oh, boys, them was the happy days!"

"*Ach,*" growled Schlosserheim, "I remember, *ja!* Und I say I get you some day iff it is *der* last t'ing vhat I do. I show you it iss funny playingk mit tricks. I should show you where you go. Coom vunce. Ve take *der* oopstarts to *der* Oberoffizier. Ha, ha, Phineas. Cats by *der* ice box, *ja?* Ho, ho! I get efen. Ha, rubber hams it giffs. *Gie schnell,* Yangkee smardt aleck!"

"Aw, you wouldn't do that," protested the prisoner. "Why, Mr. Schlosserheim, my maw won't trade no more when you go back. You wait an' see—"

"Already yedt she owes me three dollars und fifty cents," growled the Heinie ex-butcher. "*Ja,* maybe I don't go back, *nein. Mach' schnell,* smardt cracker!"

"Awright, ya big slob," cracked Phineas as he headed down a road. "But if I ever get out of this gare alive, I'll seek you out. A Pinkham never forgets."

"Dead vuns do," Schlosserheim gloated. "Hurry oop vunce."

The dismal trail led over railroad tracks through woods and out to a collection of houses occupied by a Jerry division. Schlosserheim led Phineas in to a *Herr Oberst* and turned him over.

"Pingham!" yowled the officer. "It giffs you *der* sergeant!" He yipped the promotion at Schlosserheim. "Take him out und lock him oop in *der* brick potato house, *ja!*"

The emergency klink was next to the railroad tracks. Phineas, being herded into durance vile, noted that the tracks had been hastily laid. A push from Schlosserheim rudely interrupted further observations.

"Come in an' meet me bare fists, man to man," the prisoner howled as the door was slammed and locked. "You big hunk of salami!"

When Phineas got weary of yelling his doubts about the authenticity of Schlosserheim's parentage, he took an

15-INCH FLYING MODEL KITS 15c Each—WHY PAY MORE—Quality Does Count
 Postage and Packing Charges 10c per Kit So Does Price—We Offer You Both—High Quality and Low Price
 Originally Sold for 50c Each SEND CASH OR MONEY ORDER—NO STAMPS









Actual Photos of Models Used

Also BELLANCA, MONOCOQUE, AERONCA and HOWARD IKE. FELLOWS, SAVE! ALL 10 KITS \$2.00 p.p.
 KITS CONTAIN—PRINTED BALSA—cement—FINISHED PROP—balsa cut to size—FULL SIZE PLAN
 rubber—FINISHED WHEELS—bamboo—COLORED JAP TISSUE—Instructions, etc., etc.

FREE GIFT with First 200 Orders DEALERS—Cash in on These Kits. Write Today. **1243 So. 58th Ave. Dept. B3 Cicero, Ill.**

inventory of his jail-house. It had one window that looked out upon the tracks. The cell's interior was bare save for a heap of defunct vegetables in one corner. It did not smell like an ice cream parlor.

Meanwhile, wires were frantically strumming as the news of the great capture was spread throughout *Wien-erwurst* territory. The *Rittmeister* von Schnoutz got the word and hastily groomed himself for a visit to his arch enemy.

A humming sound brought Phineas to his window. Across a fence in a cow pasture a Fokker was landing. He saw the pilot get out and walk toward headquarters.

"I hope I'll be lucky enough to only git shot," was Phineas' expressed desire as time passed. The monotony was broken by the sound of boot heels pounding the dirt outside. The door opened and Schlosserheim beckoned.

"Oudt vunce!" he yapped. "*Der Leutnant* he gedt *der* picture tooken for the *Frauleins* in Chermany. In *der* ship they catch him in vunce. *Ach,* for all the magazines—"

Jaws set, Phineas was marched over to the Fokker. Cloth had been hung over the insignia on the Jerry wagon.

"Huh, what fakers!" snorted the Heinies' many-time prisoner as a Kraut cameraman got set. "You'll fool some of the Germans most of the time an' most of them all the time, but all of them won't be fooled—"

"Get in *der* ship und look this vay, *ja!*" ordered Schlosserheim. "Loogk bleasant, blease!"

Phineas climbed aboard. Now let us not forget that Phineas Pinkham was getting quite adept at sleight of hand. Before he climbed out of the Heinie ship, his hand had been in and out of his pocket. The same hand had made a strange pass in and about the pit of the enemy ship.

"*Das ist gut,*" grinned Schlosserheim. "Now you back to *der* brison go, *ja!* Vun moof und I shoody you. *Ja,* sawdust in my hamburgers, *hein?*"

"Huh," muttered the prisoner as he was being herded back to his confine-

FREE!
with
EVERY order



Actual photo 1st Flying Vought Corsair

A COMPLETE KIT FOR THE ABOVE PLANE

A real Christmas gift for you. This kit contains EVERYTHING necessary to build the plane pictured above. Make up your order from list below, add 5c for post. on kit, and prepare for a thrill when you see our superior supplies and free kit.

- | | |
|--|--|
| <p>All Materials Guaranteed</p> <p>BALSA WOOD
18" STRIPS</p> <ul style="list-style-type: none"> 1/16 sq.35 for .05 1/16x1/829 for .05 3/32x3/3218 for .05 1/8 sq.16 for .05 1/4x1/810 for .05 1/4 sq.5 for .05 1/2 sq.2 for .05 1 sq.1 for .05 <p>18" SHEETS</p> <ul style="list-style-type: none"> 1/32x26 for .10 1/16x26 for .10 3/32x25 for .10 1/8x24 for .10 1/4x23 for .12 <p>18" PLANK BALSA</p> <ul style="list-style-type: none"> 1x31 for .15 1x61 for .25 2x31 for .25 2x61 for .45 <p>All above sizes available on 36" lengths:
Double cost of 18". Add 10c postage extra.</p> <p>BALSA PROPELLER BLOCKS</p> <ul style="list-style-type: none"> 1/2x3/8x59 for .05 1/2x3/4x57 for .05 1/2x3/4x87 for .05 5/8x1x73 for .03 3/4x1x82 for .05 3/4x1 1/8x102 for .07 3/4x1 1/4x121 for .04 1x1 1/2x121 for .06 1x1 1/2x151 for .07 <p>COLORLESS CEMENT</p> <ul style="list-style-type: none"> 1/2 oz. Tube04 1 oz. Tube05 3 oz. Can14 | <p>48 Hour Service</p> <p>MODEL DOPE BRUSHES
Per doz.10</p> <p>CLEAR DOPE OR THINNER</p> <ul style="list-style-type: none"> 1/2 oz. Bottle54 1 oz. Bottle55 3 oz. Can11 <p>COLORLED DOPE (ALL COLORS)</p> <ul style="list-style-type: none"> 1/2 oz. Bottle05 1 oz. Bottle07 3 oz. Can15 <p>WASHERS
1/8 O.D. or 1/4" O.D. per doz. .02</p> <p>JAPANESE TISSUE (20"x24")</p> <ul style="list-style-type: none"> White per doz. .20 Colored, all col., 1/2 doz. .11 <p>RUBBER</p> <ul style="list-style-type: none"> .045 sq.20 ft. .05 1/16 sq.20 ft. .05 1/8 flat17 ft. .05 3/16 flat12 ft. .05 <p>THRUST BEARINGS
Small or large2 for .03</p> <p>HARDWOOD OR BALSA WHEELS</p> <ul style="list-style-type: none"> 1/2" per pr. .03 3/4" per pr. .04 1" per pr. .05 1-3/8" per pr. .07 1-3/4" per pr. .11 2" per pr. .13 <p>BAMBOO</p> <ul style="list-style-type: none"> 1/16 sq. doz. .03 1/16x1/4 doz. .07 Sheet Celluloid 2"x602 Model Pins large pkg.05 Sandpaper large pkg.05 |
|--|--|

Ordering Instructions. 1. No orders under 50c. 2. Add 15c postage plus 5c postage for free kit. Dealers, Clubs: write for lowest wholesale list out.

MODEL AIRPLANE UTILITY CO.
5307 NEW UTRECHT AVE., Dept. F. BROOKLYN, N. Y.

FOR COMPLETE INFORMATION ON THE FREE FLYING TRAINING

given by the Army Air Corps, send for our booklet "WINGS OF THE ARMY." Flying Cadets get a salary while learning, with one year of training and 250 hours solo flying. Booklet tells how to qualify and apply. Prepared by a Veteran of the Air Corps. Price 20c postpaid. Booklet, "WINGS OF THE NAVY," gives same information on Navy Aviation. Price 20c.

CONTINENTAL SALES CO., Box 344C, Indianapolis, Ind.

USED AIRPLANES \$35.00 and up. Literature, 10c. CONTINENTAL SALES CO., Box 344C, Indianapolis, Ind.

CHEMICAL

Outfits 10 Scientists

MICRO PHOTO

Amateur Supplies

Brings You this complete catalog listing hundreds of items of interest to the amateur experimenter. SPECIAL 30 DAY OFFER for those who send immediately.

J. H. WINN MFG. CO., Dept. 50, 124 West 23rd St., New York



Free Offer

IMPERIAL LEADS IN QUALITY AND VALUE

<p>18 IN. SHEETS 1/32 and 1/16x2 6 for 10c 1/8x24 for 10c 1/4x23 for 12c</p> <p>18 IN. PLANKS 1x1 1 for 7c 2x2 1 for 20c 1x2 1 for 11c 2x3 1 for 25c</p> <p>BAMBOO 1/16x1/1636 for 5c 1/16x1/4x151 for 1c Dozen 8c</p> <p>THRUST BEARINGS 1c each 10c doz.</p> <p>WIRE 2 ft. 1c 25 ft. 10c</p> <p>INSIGNIA SHEETS 24 and strips5c</p> <p>WASHERS 1 doz. 1/8x1/41c</p> <p>BUSHINGS 1 doz. 1/2x1/23c</p>	<p>BALSA OR BIRCH WHEELS 3/8" .pr. 2c 1" .pr. 4c 3/4" .pr. 3c 1 1/2" .pr. 5c 1 3/4" .pr. 10c</p> <p>3" in Balsa only 17c</p> <p>SHEET CELLULOID 6x85c 12 1/2x16 20c</p> <p>CELLULOID WHEELS 3/4" .pr. 5c 1 1/2" .pr. 10c 1 3/4" .pr. 7c 1 3/4" .pr. 17c</p> <p>WOOD VENEER PAPER 20x301 for 10c</p> <p>RUBBER 1/16x1/1618 ft. 5c 1/8 flat15 ft. 5c .005 in. thick, 15c sq. ft. .010 in. thick, 20c sq. ft. REED2 ft. 1c</p>	<p>PROPELLER BLOCKS 3/8 x 3/4 x 66 for 5c 3/8 x 1 x 73 for 5c 3/8 x 1 x 83 for 5c 3/8 x 1 1/2 x 121 for 4c 1 x 1 1/2 x 121 for 7c</p> <p>CLEAR DOPE 1 oz. bot.5c 1/2 pt.30c</p> <p>COLOR'D DOPE 1 oz. bot., all colors, 5c</p> <p>CLEAR CEMENT 1 oz. bot.5c 2 oz. bot.10c 1/2 pt. bot.35c</p> <p>JAPANESE TISSUE 1 doz., all colors, AA, 19c Thinners, 1 oz. bot., 5c Sandpaper, Package ... 5c Prop. Shafts, dozen ... 5c Nose Plugs, 2 for 1c</p>
--	--	--

20 IN. FLYING PLANES (0-3 for 25c)
 Texas Sky Chief, Sparrow Hawk, Boeing P. 12-F, Gee-Bee, Boeing Trans. 247, Saco Chas. Vought Corsair, Curtiss Swift L. W., Fokker D-7, Waco Cabin Bi-plane, S. E. 5, Fairchild 24, Douglas Dolphin.

DEALERS! JOBBERS! CHAIN STORES!

6 Inch Solid Kits

\$4.10 Gross ... F.O.B. Bklyn, N.Y.

Dealers take advantage of this big offer . . . a regular 10c retail 6" solid kit with printed plans and instruction sheets and printed Balsa sheets, insignia sheets, cement, etc. \$4.10 a gross f.o.b. Brooklyn . . . also 1/4" flat rubber 55c p.c. lb. Write for our low prices on balsa wood, other supplies and accessories. Write for exclusive big dealers pricelist on your business stationery.

DIAMOND MODEL MFG. CO.
915 Saratoga Avenue Brooklyn, N. Y.

NEW! BALSA STAMPING PRESS



Completely assembled machine with full set of adjustable dies for wing ribs, fuselage formers, etc. Make 12" to 36" kits for all types of model planes. Simple to operate! Just slip in a plain sheet of balsa, strike the handle and out comes a ready-cut part for your model. A money-saver for clubs and builders. Not a toy but a real serviceable machine. Built to last.

Remit check or money order

175

plus 25c postage

SEAKAY AIRCRAFT, 24 West 20th St., New York

New! ALL ALUMINUM MODEL AIRPLANES

This is the first time in the Model Airplane industry that all-aluminum model airplanes have been offered to the buyer of models.

The all-aluminum airplane is the nearest thing yet to the real airplane. It embodies the same principle in construction, such as welding all joints, using all aluminum, the wing construction, fuselage, tail, etc., all made from aluminum tubing, sheets, etc.

LEARN HOW TO BUILD A REAL AIRPLANE

The kits and sets are fully complete. No tools are needed, all parts are completely finished, stamped out. There is no time lost to cut out parts, to make this or that. The plans are fully illustrated, showing every move in construction. Each step is illustrated so that even a six-year-old can make a model.

Send Stamp for Literature

DEALERS WANTED

AT LAST — THE ALL ALUMINUM MODEL

ALUMINUM MODEL AIRPLANE CO.
NEW HYDE PARK, N. Y.

ment. "I am glad there's no wind. One Kraut will git—"

"What iss idt you say, hein?"

"Noddings," grinned Phineas. "I'll die happy, knowin' that my last act was—well, er, just skip it."

PHINEAS was not back in his prison five minutes when a clatter and a rumble drowned out every other sound. He went to the window and looked out. An iron horse belonging to the Kaiser was rattling over the railroad tracks. Its stack was belching smoke. Then steam hissed, and the wheels grated against the steel ribbons. It wheezed to a stop, and not fifty yards from where Phineas was incarcerated, he could see a closed box-car with straw sticking out from under the side door. The Kraut engineer got down and walked to the rear of the train, where smoke came out from under a flat-car.

"Huh," laughed the prisoner, "a hot-box! No wonder, with that boilin' sun an'—sun, hey? Hm, why—well, I wonder." He took the mirror from his pocket and held it up to the window. The sun's rays flashed against it, deflected a stream of heat.

An hour passed. The crew of the Heinie train were lolling beside the tracks. The engineer and some Kraut infantrymen were still administering to the rear flat-car. Phineas ached in every muscle. Sweat poured from his brow. Then he whistled through his teeth and prayed for the sun to bear down. A curl of smoke came up from the straw sticking out through the car door. The roar of a Mercedes came from out of the torrid ozone as the straw caught flame.

Phineas dropped his mirror and flattened himself to the floor. It was two more minutes before a wild yell of terror came from Kraut throats. Phineas lifted himself and looked out of the window. Smoke was belching from the box-car.

"I'm glad this is a brick joint," the Boonetown warrior grinned, and emulated a turtle once more.

The *Rittmeister* von Schnoutz was striding down to get a look at Phineas Pinkham when all hell broke loose. A grenade started it off. Bo-o-o-o-o-o-o-o-oom! Wham! Blooey! A terrific detonation blew the door of Phineas' abode from its hinges. Smoke billowed up. Cordite fumes choked off Heinie yells.

Machine-gun bullets hummed crazily. It was a fireworks shop magnified nine million times, going berserk. Phineas ventured once to raise his head to view his handiwork. He saw a flat-car lift from the track and spin down the bank. A Kraut, flat against a door, sailed through space like Sinbad on a rug. Two white-faced Germans dived into the brick house.

"Ach, Gott!" yelled one as a shell tore off the side of the klink. "*Donner und Blitzen!*" It was Schlosserheim.

"Oh, good afternoon," said Phineas, and smacked the Boonetown butcher on the point of the jaw. "I told ya!" He whipped the coal hod from the butcher's head and slammed the other Heinie in the belt line.

"Adoo!" Phineas yipped, and headed out toward a spick and span Albatross that was ticking over where von Schnoutz had just left it a moment or so before. Bullets-hummed like honey bees. Shells shrieked and grenades still popped as the Boonetown jokesmith made a leap for the alien crate. From a cellar window, von Schnoutz saw and let out a terrific yowl.

"Shells mit potato mashers I shouldt mind. Pingham! I gedt him!" he roared. "Cheated am I, hein?" He leaped over several good Germans and tore for the Fokker that shook and shivered in the pasture. The pilot had managed to get it going, and was climbing into the pit.

"Oh, you vill, hein?" roared von Schnoutz, like the villain in a melodrama. "Oudt you coom. I fly der Fokker. Ach, der fight you pudt oop, ja!" Kerwhop! A bullet sliced across the bridge of the *Rittmeister's* nose as he climbed into the pit.

Phineas' big ivories were bared in a pleased grin as he lifted the Junker job toward the roof. At a thousand-foot shelf, he spotted a great *Staffel* of Heinie crates high above.

"Well, they will judge the book by its cover, haw-w-w!" he guffawed. "They—" He looked back. Out of the billowing smoke that welled up from the shellacked ammo train came a Fokker, as if it had been shot from a catapult.

"Huh," mused our hero, "they're just itchin' to git me, haw-w! Anyways, I hope so."

In the Fokker pit, von Schnoutz swore and wiped at his goggles. He spat out something that had fouled his tongue.

"Himmel!" he gutturalled. "Such dust! *Das ist* funny, hein? Soot maybe it giffs from der railroad engine. Ach, Pingham, I am after you, ja! Today I fly der Albatross, und somet'ing it iss wrong mit. Tventdy miles by der hour it looses der speedt. Ho, ho!"

It was dawning on Phineas at that very moment that the Albatross was indeed flying under protest. Yard by yard, the pursuing Fokker crept up on him.

"This crate sure has got lead in its pants," he gulped. "It looks like I'll have to turn an' fight the bum. Well, I'll sell my life dear an' —"

Von Schnoutz, teeth grinding, saw the Albatross loom up bigger and big-

ger in his ringsights.

"Vun joomp yedt und I am in range, ja!" he yelled. "By chiminy, vot was ist?" His face tingled. His nose itched like a double case of hives. The itch crawled down his neck. His bare hands felt as if they had been buried in a clump of poison ivy. Sweat began to roll down his face. It seemed to aggravate the unbearable itch.

"Himmel!" von Schnoutz yelled, and a hand that had strayed to Spandau trips jerked back to paw at his nose. He squirmed in the pit, took his hands from the stick and rubbed his knuckles against his knees. The Fokker lurched and he clutched the stick.

"Gott!" yelped the Rittmeister. "Nefer vas such an itch!" He steeled himself to look for the whereabouts of the errant Phineas.

A burst of lead through the Fokker's tail brought a gasp of fright from the Junker's throat. The Boonetown flyer was on his neck. Into a loop went the Rittmeister. At the top of it, he let go of the stick and scratched at his neck, his nose, his knuckles. The itch was crawling down his torso and had reached his diaphragm.

"Donnervetter, was ist?" screamed the Junker pilot as his Fokker, given its head, started to imitate a whirling dervish. "Rotten ist somet'ing, ja. Somet'ing I shouldt do it." Squirming like a worm on a hook, von Schnoutz fought to subdue the Fokker.

"Take that an' that—an' those!" howled Phineas at the stick of the Albatross as the two crates gyrated over the Yankee trenches. "Oh, boys, that's powerful stuff. Lookit him scratch! How would ya like to have a wire back-scratcher, huh?" And he slugged the Fokker with another Spandau burst. It slammed home just as von Schnoutz pulled out of a spin. The shot kicked the Fokker over on its ear again and the Rittmeister in the pit let it go to rub his nose against his sleeve.

"To hell mit!" groaned the itching Kraut. "Maybe yedt the Amerikaners haff der liniment what shouldt stop der itch. Gott im Himmel!" One hand scratching, the other on the stick, von Schnoutz picked out a landing site.

The crippled Fokker hit the ground, bounced three times, then landed without benefit of wheels. The ship skidded across five hundred yards of mud, spun around in a dizzy circle and piled up against an embankment behind which was a Yankee machine-gun nest. Von Schnoutz parted company with the wreck and flew into space, still scratching.

YANKEE doughs were digging the Rittmeister out of the mud when Phineas Pinkham got to the spot. Three of the doughs jabbed bayonets at his mid-section.

"Lay off the hara-kiri," yowled the Boonetown flyer. "Look, I'm on your side, ya bums."

"Shoos," grinned one of the threateners. "whatsa mat' you fly Botcha sheep?"

"I t'ank mabbe ve shood him anny-vay, yah?" added a big Swede.

"By gar, she is wan spy, what you t'eenk, O'Brien?"

"Haw-w-w-w-w!" hollered Phineas with an ear-splitting grin. "When do ya think the Americans will come over, huh? Well—I'm a—what the—for—the—it's von Schnoutz! Fancy you bein' here, Ritzmaster. Why—haw-w-w-w-w! Ya still scratchin'?"

"Mein Gott!" yowled the Heinie, scraping mud from his face. "Nefer iss idt sooch vun itch. Nein, idt iss nodt so. Dreamink, I am—vun nightmare vunce. How iss idt you know I fly der Fokker? Ach, der itch!" And the Rittmeister went into a series of contortions as he tried to reach every section of his anatomy at one and the same time. "Gedt idt der gun und shoodt me. Itches mit tingles mit burns. Der defil iss idt you are, ja!"

"That powder itches like hell, awright," Phineas grinned. "When they put me in the crate you flew to take my picture, I just poured it all around the pit so's when the prop spun, somebody would git dusted. Haw-w-w! It's fifty times worse when you git hot. Well, don't you think we'd better git started as it's close to tea time, an'—"

On the drome of the Ninth Pursuit Squadron, Bump Gillis sat in a chair in front of the Frog farmhouse, trying to get rid of a flock of nerves. A meat-wagon attendant was sponging a big bump over the lieutenant's right eye. One foot was bared, and across the sole of it was the trademark of a tracer.

"Well, at least I got back," Bump was saying. "Carbuncle went to the showers this time. You couldn't bomb one of them trains with two hundred Spads wrapped up in armor. How about a transfer?" he barked at Garrity.

"I think I'll resign, too," the Old Man growled. "There's no fun in this gare any more. Now that—"

A yell from the door of the farmhouse separated Garrity from his wits.

"What the hell are you howlin' about?" he tossed at the Recording Officer, who was jumping up and down and throwing papers in the air.

"O!" Phineas just called up," the R.O. announced between hilarious shouts. "Phineas! He wants to talk to you."

Everybody tried to get through the door at once. The Old Man pushed and punched his way to the phone and grabbed it up.

"Hello, you fathead," he yipped. "Where in hell—"

"I'll be there in two hours," the Boonetown wonder's voice bellowed over the wire. "Have ya heard what I done to the Heinie ammo train? Oh, you will? An' set another plate at the table as who am I bringin' home for supper, who?"

"I bet it's Foch," cracked Garrity. "You big ape!"

"Nope, it's my pal von Schnoutz," was the rejoinder from the other end of the line. "I had to knock him down as he got in my way. He was sure up to scratch, haw-w-w-w-w! He likes his eggs fried on one side, major. Well, adoo. But wait—I want you to tell the fresh bums somethin'."

New C-D "Dwarfs" Instant Sensation!

Spectacular New Line of 1/2" Authentic Scale at only 25c to 85c

Just in time for Christmas—Cleveland's new Dwarf line of 1/2" scale models announced by popular demand made on us for C-D quality, lower priced, smaller kits. Each Kit entirely complete (as are all C-D models), except "Dwarfs." DO NOT contain CEMENTS OR DOPE. They are exactly 2/3 the size of the 3/4" scale SF models, so take descriptions given, using the same design number, but the prefix, instead of being SF is D, and use 2/3 the given sizes. In addition to the ones shown, we also offer D-1G, Great Lakes Sport Trainer 65c, D-8C, Boeing P12-E 65c, D-20B, Hawker Fury 45c, D-26, Heath Parasol 35c, D-27, Gee Bee Supersportster 50c, D-33, Comper Swift 30c, D-40, Aerona 60c, D-41, Vought Corsair 85c, D-42, Howard Ike 25c. 10c extra for postage on each Kit must be included. Watch your dealer's stock for additional numbers. Absolutely nothing else ever like them. Remember—NO LIQUIDS.

NEW DEAL FOR DEALERS!
See Below



'32 Boeing P26
Span 21 1/4", length 17 7/8", wt. 2.5 oz. Yellow and olive drab. Complete Kit SF-23 \$2.50
Kit D-23 65c



'32 Douglas O-38
Span 30", length 28 3/4", wt. 4.8 oz. Yellow, olive drab, black details. Printed out wood. 2 pilots, etc. Complete Kit SF-43, only \$3.75
A very beautiful and unusually detailed model.

Kit D-43 85c



1933 WACO C
Span 24 3/4", length 19 1/4", weight 8.7 oz. Silver and red. Complete Kit SF-37 \$3.25
Kit D-37 75c

All 3/4" Kits Contain
Printed out wood. Pilot blocks for carving. Coloring for same, as well as for propellers. Thread (mostly new silver gray) for bracerwires. All strip wood necessary. Sufficient dope, cement and tissue cement. Insignia, striping tape, etc., etc. In fact—EVERYTHING to build a REAL model.



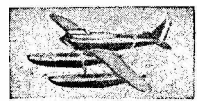
'33 Boeing F4B-3
Span 22 3/4", length 15 3/4", weight 3.2 oz. Silver, yellow, red. NOW HAS PRINTED OUT WOOD. Super complete. Complete Kit S.F.-29 \$2.85
The pride of many C-D fans.

Kit D-29 65c



LOCKHEED VEGA
A picture for beauty—a wonder for flight. Span 30 3/4", length 21", weight 3.7 oz. Colored brilliant red & Cream. Kit SF-24 \$3.25
Kit D-24 85c

Read before Ordering
Many responsible dealers are now putting in C-D stocks. See your dealer. If you order direct, remember—Special Delivery 20c extra per Kit, C.O.D.'s 25c each order, accepted only when \$1.00 is remitted to assure acceptance. We pay postage on all SF Kits; on "Dwarfs" be sure to remit 10c per Kit postage charge. SEND 5c for Catalog.



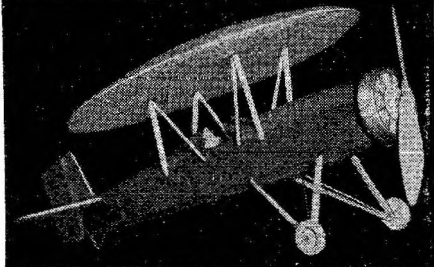
'32 Supermarine S6-B
Span 22", length over all 21 3/4", wt. 2.9 oz. Will R.O.W. Silver and Blue. Kit SF-19 \$2.50
Kit D-19 65c

DEALERS!
We have re-established our dealer setup on an entirely new basis. We invite all responsible established dealers to wire or write immediately for complete details of this "New Deal". Liberal discounts. Rush service. And the finest model airplane sales opportunity ever offered. Every single one an authentic scale model. ACT ONCE for getting a big share of C-D Christmas business!

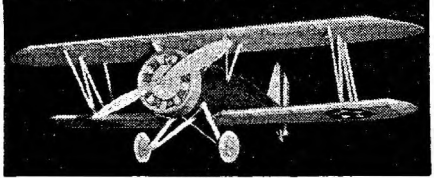
CLEVELAND MODEL & SUPPLY CO., Inc.
1866FAA West 57th Street, Cleveland, Ohio, U. S. A.

For a Very Merry Xmas, Give..
MADISON FLYING SCALE 50^c
 Most Complete Kits Offered **MODELS 50^c** Post-paid

The complete kits that model builders are "raving to the skies."
 Other models are HELL DIVER, FOKKER D8, DeWOIT-INE D-33, VOUGHT CORSAIR 03U-4, JUNKERS D-1 and WACO TAPER WING-220. All at 50c ea. postpaid.



MADISON UMBRELLA TYPE (28 in. circum.), 50c pp.



15 in. BOEING P 12 B Army Pursuit Plane, 50c pp.



15 in. WEBELL WILLIAMS Famous Racing Plane 50c postpaid

Remit Cash or Money Order Canada: add 15c on each kit.

MADISON MODEL AIRPLANES, Inc.
 134 F. Livingston St., Brooklyn, N.Y.
 On Sale at Leading Department Stores Everywhere

Dealers! Jobbers!

Follow the Duncan Line to new profits. Increase your model airplane business by stocking Kits, Plans and Parts designed by Joe Ott, nationally known model authority. A new deal on balsa wood and other materials. We sell to jobbers and dealers only. Standard discounts. Write now. No obligation.

It will Pay You to WRITE to MODEL AIRPLANE Headquarters

New, BIG Selling Items Every Week

Let Us Put Your Name on Our Mailing List

MANUFACTURED BY
DONALD F. DUNCAN, INC.
 1502 S. WESTERN AVE., CHICAGO.

LINCOLN-TRAINED MEN
 are Finding Good Pay Jobs in AVIATION

LINCOLN graduates are in demand. A recent report from our employment department lists 10 more of our graduates who have obtained good jobs among prominent concerns in the aviation industry. These and many others have found profitable employment in aviation after completing their training in this world's best known school. This school is constantly in touch with the aviation industry, with a view of placing its graduates in trusted positions.

No guess-work about your getting proper training at LINCOLN. Only modern, high class training planes with Department of Commerce approval are used. Training given for government license as Transport, Limited Commercial, Private or Amateur Pilot.

Ground and mechanics school with experienced instructors qualify you as Master Airplane and Engine Mechanic. Government Approved School. 24 years' experience as successful mechanics trade school. 14 years successfully teaching aviation. Write now. State age.

LINCOLN AIRPLANE & FLYING SCHOOL
 2036 Aircraft Bldg. Lincoln, Neb.

Garrity listened. Necks craned and ears wobbled as the buzzards tried to get in on it. Finally Garrity planked the receiver down. The phone began to jangle crazily.

"Let the Brass Hats wait," grinned

the Old Man. "You know what he said to tell you guys?"

"Go to hell, I bet," ventured Howell. "Wrong!" said the major as he stretched himself. "He said to tell you he did it with mirrors, ha, ha, ha!"

Happy Landings

(Continued from page 25)

of his big toe could still have been fired from the ground. For instance, if a man is banking sharply near the ground, and a machine gun a few hundred yards away is firing from a ground position at an angle, there is every possibility that he can be hit on top of the head by a bullet.

Another interesting angle is the fact that Lieutenant Travers saw it take place while he was on duty on Corbie Hill. The German observers report a red triplane landing on Corbie Hill. Roy Brown's story is that he engaged the German over a point which he calls Vaux sur Somme, but I have been unable to find any such point on any of my old war maps. However, this is unimportant, since the records show that Hamel, Saily-le-Sec and Corbie are mentioned in other reports. Still, I would like to know just where this point is, for I do not recall it, and I spent many months in that area.

From what we can see, we shall have to choose between the records compiled by Floyd Gibbons and those stated by the various Australians. Personally, I have no preference in the matter, and recall that nowhere does Brown himself claim to have downed von Richthofen. His report states that on April 21st at 10:45, he engaged a red triplane with small black crosses which was firing on Lieutenant May. He states that he fired a long burst into the German plane and it went down vertically. He also says that Lieutenants Mellerish and May saw von Richthofen crash.

However, actually the machine landed, rolled toward a shell hole, ripped off a wheel and stayed right side up.

Gibbons goes further, and states that von Richthofen was found still in his seat, with the stick between his knees and blood trickling down his face. He says, too, that Mellerish, who had been driven down to land in the Australian lines, walked over, took charge and made the actual identification; that the ship landed in between the trenches and could only be reached by men crawling from shell-hole to shell-hole. Therefore they approached it under fire, tied a rope to the wreckage and dragged it to a shelter under a low rise in the ground.

This certainly does not agree with the report of the Australian who was actually there. Travers says that Captain Cruickshank took charge and carried von Richthofen's papers back to his Brigade Headquarters. But both Gibbons and Burrow seem to agree on the bullet wound.

It would be interesting to get this straightened out.

If Brown fired on von Richthofen and

sent him down vertically, how was it that the ship landed practically unharmed? If Mellerish landed behind the Australian lines, how did he get all the way back to a forward area where machine-gun fire was so bad they had to crawl in and out of shell holes to get to the ship? If Australians were milling around, cutting crosses off the red triplane, there could have been little danger of machine-gun fire from the German trenches.

It should be explained here that when Brown returned to his squadron and made out the report about his fight with a red triplane, he did not know who its pilot was. Naturally, he did not make a direct statement about downing von Richthofen. And as far as we can find out, he never has, which is something to his credit.

Then when the word came through from Corbie that von Richthofen was down in a red triplane, Colonel Cairns, Brown's Wing Commander, ordered Brown to accompany him to Corbie to identify the machine. At Corbie, they found Mellerish and, with the aid of May, who also went back with Brown, the Canadian captain was able to identify the machine, we are told. This appears to be enough evidence, if Gibbons' story is true. But is it?

After this, the story is fairly clear. The triplane and von Richthofen's body were taken to Bertangles and placed in a hangar there. For a day or so, every British airman in the vicinity came and paid his respects, or satisfied his morbid curiosity by visiting the remains. Brown refused to go anywhere near it, or even to talk about the fight. As a matter of fact, he went on patrol again the next day and, if we are to believe Floyd Gibbons, fought the German circus again. But this time he came back, collapsed and was delirious for three weeks. After six weeks of treatment in an Amiens hospital, he was returned to England, where he took up combat training work. He also was rewarded with a bar to his D. S. C., a medal he had won while a member of the Royal Naval Air Service.

You who are not acquainted with the system of British decorations and their seniority will have to be told here that when one is awarded a bar to a medal, it is the same as being awarded the same medal again. Now, the D.S.C. is no Victoria Cross, by any stretch of the imagination, although it is well worth winning. Between this medal and the Victoria Cross, for instance, there are the D.S.O. (Distinguished Service Order) and one or two others, such as the Distinguished Flying Cross and the Air Force Cross. The last two came in with

the formation of the Royal Air Force.

It does seem to us that if the British government had been satisfied that Brown had actually put an end to the great von Richthofen, they would have considered him for at least the D.S.O., or even a V.C. But no—they gave him a bar to his D.S.C.! While the British were pretty tight with their high honors, there seems to be something wrong here if Brown *did* get von Richthofen.

Still, we shall never know, I suppose. Personally, I would like to prove that Brown did get von Richthofen. After all, it would be a more fitting way for a gallant airman like the German to go out, and we feel sure he would have had it that way. But as the years roll on,

new and conflicting testimony crops up, and we cannot forget that while Brown has been showered with the credit for downing the Red Knight, he himself has never made any such declaration. There is no question that he shot a red triplane down that day, and added another to the dozen he already had, but somehow these strange stories that continue to come out of Australia take some of the glow away. Perhaps, if we keep working on this case, we will be able to prove conclusively that Brown did get the famous German airman. Perhaps some of our readers in the United States, Canada, England or Australia have further proof or testimony to offer. If so, we will gladly publish it.

The Squadron That Would Not Surrender

(Continued from page 20)

painting.

"Not until we've won our game," Stark told the art critics who begged him to quit the air.

"Won? The war is turning against us now," one man told him.

"I mean our game against that damned First Squadron," the artist-ace responded.

The critics shook their heads, but the ace would not argue. Too many of his friends had fallen before the Vickers of England's premier squadron. He planned raids that would catch the British unawares. But when the Germans struck, they swept up from the ground and fought the Thirty-fifth to a standstill. Arthur Hazel and Clayton developed into super-aces in their struggles with these determined Boche. Although the great *Kaiserliche Schlacht* had failed in the Champagne and in the Artois, the struggle in Flanders became more bitter.

MMURMURS came from far behind the German lines. Others besides the art critics were anxious to quit warring. Then dawned that Black Friday which Ludendorf has called the darkest day in the history of German arms. Civilian support to the army was crumbling. The end was near.

"Others may quit, but not the Thirty-fifth," Stark told his pilots.

"Never!" they yelled.

Hands were raised, and each man swore he would die before he would surrender. The squadron kept in the air almost constantly as the days shortened and the winter of 1918 neared. Stark painted no more. The days of glory were near their end. He had limned German victories on many canvases, but now only defeat attended the struggles of the Teutonic giant.

November began with short days, storm-swept and dark with rain, but the artist-ace took his men into the sky and attacked again and again. It was always the First Squadron that felt the fury of his assaults, but the boyish veterans of the old formation answered his challenge and traded lead for lead. Some of Stark's most beloved aids were

killed by Clayton and Hazel over the now receding lines. The German war machine was moving out of Flanders.

Stark raged against the fate he saw foreshadowed. "We'll never quit," he muttered again and again.

Then came November 11, 1918. The eleventh hour of the eleventh day of the eleventh month saw the end of the long struggle. Orders were issued to the squadron commanders to surrender their ships. To *Rittmeister* Carl Bolle of the Boelcke unit came an order that made his rugged face turn pale, but he prepared to follow it.

Captain Rudolph Stark received instructions to surrender his Fokkers and other war materials to Captain P. J. Clayton, temporarily the commander of the British First Squadron.

The artist's cheeks were drained of blood.

"Not—to them!" he swore, as he re-read the order.

He turned to his pilots. They had sworn to die. He explained the context of the orders he had just received. The German army was crumbling. Officers were being stripped of their insignia. Soldiers' and sailors' councils were being formed. The old order was passing into oblivion. War had been a glorious canvas to Rudolph Stark. Now it presented a soiled and dismal picture.

"We will not give up our ships," the pilots shouted.

"We can die," the chief reminded them.

"*Ja wohl*—yes, indeed."

Eleven o'clock, November 11, 1918, saw the Thirty-Fifth drawn up upon its tarmac. The Fokkers were freshly serviced. Each tank held all the gasoline and oil it could contain. Spandaus were fitted with full belts of ammunition. Others were on the cockpit floors.

The hour had come, and the British were crossing the low, flat ground to take over the squadron.

Rudolph Stark sat in his Fokker D-7, a ship which had played a large part of his acedom. He loved it as a cavalryman loves his charger. He saw the British coming, and he held his arm aloft. Riggers and mechanics sprang to the



Say—

"Merry Xmas"

and make it last
a whole year.

Here's a most welcome gift for any model builder, young or old. Whether for giving or receiving, it will be a huge success either way. There's nothing that could possibly bring greater enjoyment than a

12-MONTH
Subscription to..

UNIVERSAL
MODEL
AIRPLANE
NEWS

"THE ONLY MAGAZINE DEVOTED EXCLUSIVELY TO EXPERIMENTAL AVIATION"

As each month rolls around and as each new issue is delivered by the mailman, there will be plenty of pleasant thoughts for the giver. Give subscriptions to UNIVERSAL MODEL AIRPLANE NEWS this year! Solve a perplexing gift problem and be assured of giving "just what he wanted."

Wherever requested (see coupon below) we send an attractive gift card in advance to inform the recipient of this marvelous gift and its giver.

Don't pass up this Great Holiday Offer! Now would be a good time to get your coupon in. Twelve live, new, interesting issues of

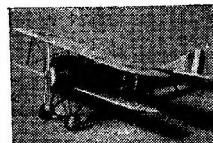
UNIVERSAL MODEL AIRPLANE NEWS at

~~2.00~~ \$1.65 ~~2.00~~

means that you save 75 cents
and in addition you also receive

These 2 Kits **FREE!**

Complete! Ready to Build!



(At left)—the well-known S.P.A.D. (Below)—War fighter NIEUPORT



Regular 75c value. Complete with correct insignia, lacquer, metal props, balsa, done and plans to build BOTH MODELS.

These 2 kits of famous War-time planes will enable you to build lifelike models reproduced in perfect detail (1/4" scale). Great enjoyment to old and young model builders alike. These kits will be sent FREE with every subscription.

This liberal holiday offer expires Jan. 1, 1935. Don't miss it! Tell your friends about it!

Mail This Coupon NOW!

JAY PUBLISHING CORP. Dept. FA-1
551 Fifth Avenue, New York City.

Enclosed find \$1.65 for which please send to the address below, UNIVERSAL MODEL AIRPLANE NEWS for one year, together with the S.P.A.D. and NIEUPORT Construction Kits absolutely FREE.

Name

Age

Street

City State

If Advance Gift Card is to be sent, check here

SUPPLIES . . .

. . . at the lowest prices quality supplies can be sold for.

Experts and beginners alike are fast becoming acquainted with our fine quality and fast service. That's why our business has increased more than ten times over last year.

36" Balsa Double 18" Cost	10c	Thinner	1 oz. 6c	2 oz. 10c
18" Strip Balsa	5c	1/6x1/16	4 oz. 16c	Pint. 50c
1/16x1/8	20 for 5c	Colored Dope		
1/16x3/16	16 for 5c	All Colors		
1/16x1/4	12 for 5c	2 oz. 12c	4 oz. 20c	
3/32x3/32	20 for 5c	Bamboo		
1/8 x1/8	16 for 5c	1/16x1/4x15"	doz. 8c	
1/8 x3/16	12 for 5c	Shredded 10 1/2"	doz. 75 for 5c	
1/8 x1/4	10 for 5c	Jap Tissue		
3/16x3/16	8 for 5c	White	2c ea. doz. 22c	
1/4 x1/4	6 for 5c	Colored	3c ea. doz. 28c	
1/4 x1/2	4 for 5c	Thrust Bearings		
1/2 x1/2	2 for 5c	Large or Small		
18" Sheet Balsa		3 for 4c	
1/64x2"	4 for 10c	Washers		
1/32x2"	6 for 10c	1/4" O.D. and 1/2" O.D.		
1/16x2"	6 for 10c	3 doz. for 4c	
3/32x2"	6 for 10c	Music Wire (Straight)		
1/8 x2"	4 for 10c	.014, .020, .028, .034		
3/16x2"	3 for 10c	2 one-foot lengths 1c	
1/4 x2"	3 for 12c	Para Rubber		
3/8 x2"	2 for 12c	1/16" sq. 25 ft. 10c		
1/2 x2"	2 for 14c	1/8" flat. 25 ft. 10c		
18" Plank Balsa		225-ft. skein 60c		
1"x1"	1 for 6c	3/16" flat. 25 ft. 15c		
1"x2"	1 for 11c	225-ft. skein 80c		
1"x3"	1 for 15c	Cell. Balloon Wheels		
2"x2"	1 for 18c	3/4" pr. 6c 1 1/2" pr. 10c		
2"x6"	1 for 45c	1" pr. 7c 1 1/2" pr. 14c		
Balsa Prop Blocks		Bushings 4 for 2c	
1/2 x 3/8"	6 for 5c	Sheet Celluloid		
1/2 x 1/2"	5 for 5c	6"x8" 5c		
3/8 x1"	3 for 5c	Machine-Carved Propellers		
3/8 x1 1/4"	4c	5" 5c	8" 8c	
3/8 x1 1/2"	5c	6" 6c	10" 10c	
1 x1 1/2x15"	8c	7" 7c	12" 12c	
Clear Cement		Cell. Dummy Motors		
1 oz. tube 7c		(with or without		
2 oz. tube 10c		Drag Rings)		
4 oz. tube 18c		1 1/2" 20c	3" 35c	

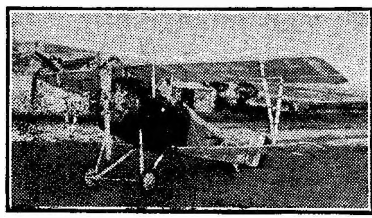
FREE No extra charges, usual high Berkeley Quality 1/16x1/16x18 100 Balsa Strips (with every \$1.00 order)

NOTE WELL: Include 15c Packing Charge with every order. Canada 10c extra.

DEALERS—CLUBS—Send for Special List

BERKELEY MODEL SUPPLIES

53 Berkeley Place Dept. F.A.-5 Brooklyn, N. Y.



NIEUPOORT 17 SPAN 15"
Actual photo of flying scale model photographed against a painted background.

Kit contains printed balsa, finished wheels and nose plug, new type propeller which eliminates carving, colored insignias, wire parts, explicit plan, dope, cement, etc.

PRICE **35c** PLUS
PER KIT 5c POSTAGE

DEALERS
Handle the LINDBERG line

We have moved into our large, modern factory, and we are better equipped to give our customers the best of service.

LINDBERG MODEL & SUPPLY CO.
5324-28 No. Kedzie Ave., Chicago, Ill.

NATIONAL AERO RESERVE

Boys and young men interested in ANY phase of aviation will find that it pays to be an NAR member. Convince yourself!

Wings, contests, photos, models, instruction, etc. Send 10c for full details and application blank. Address:

NATIONAL AERO RESERVE
Dept. F 114 W. 16th St., N. Y. C.

BE A DETECTIVE

Make Secret Investigations

Earn Big Money. Work home or travel. Fascinating work. Experience unnecessary.

DETECTIVE Particulars FREE, write to
GEO. G. WAGNER, 2640 Broadway, N.Y.

Fokkers and started their props. The English were near. Stark waited tensely. Then, as the khaki-clad figures reached the reservation on which the airdrome was built, the commander's arm dropped. With a roar, the Fokkers swept across the field.

The squadron slid into the air, disobeying the orders of the High Command and violating the terms of the Armistice. Stark led his force across the lines to where the First Squadron was housed. A note was dropped upon the field.

"The Thirty-Fifth refuses to surrender. It is ready to die."

Stark's men circled, staring down upon the massed ships of their enemies. They saw curious faces staring up, but no plane left the ground.

"They are cowards," Stark grated, "They are afraid to fight."

But while he hovered over the field, Captain Clayson was busy telephoning to his wing commander.

"These chaps won't surrender. What shall we do?" he asked, "They're a rather a sporting crew. Perhaps we should humor them. Give them a bit of a fight and—"

"You may not," Wing broke in. "Let them fly. They'll have to come down for gasoline. No more fighting. The war is over."

"But, colonel," Clayson begged, "just let us—"

"You will follow orders," was the crisp interruption.

Captain Clayson reluctantly remained upon the ground. Signal panels were put out, inviting the Boche down, but they only increased Stark's rage. He wanted to die, to die fighting, but the British wouldn't fight. What was he to do? He knew his gasoline supply would soon be low. He couldn't go back to the old landing field. The ground crew undoubtedly had already surrendered.

At a signal with his wings, the Fokkers swung around, nosing for the east. The squadron followed blindly, knowing

that their commander would do something worthy of his fame. They, of all German formations, would fight to the last.

They swept across the terrain strangely alive with humanity. For the first time in four years, men appeared above ground without being greeted by storms of steel and high explosive.

Rudolph Stark scanned the skies with his glasses. No planes were on the wing. He wanted to meet American, British or French squadrons in battle, and fight until not a ship remained in air.

They circled over several fields and dropped notes of challenge. All were ignored. The story of the runaway squadron had been flashed across the Front, and the victorious Allies were denying Rudolph Stark the pleasure of a last, magnificent gesture.

Turning east, again, the squadron swept across Metz, now thronged with Allied soldiers. It picked up the Rhine and then entered the Black Forest area. Stark knew this country. It was his fatherland. Far off to the right was a training field. He would come down there and refuel his ships. Unless the Allies hopped off to attack him, he would force them into action by assailing the undefended men upon the ground.

Night was near when they descended. They obtained enough gasoline for several days. Meantime, they would force the Allies to hunt them down and kill them.

"Sleep well, my gentlemen," Stark told his pilots. "Tomorrow we shall make history—German history."

But the morrow found all things changed. Some pilot, whose name shall ever be anonymous, stole from his bunk in the early morning hours and fired the gallant Fokkers which Stark had refused to surrender. The beloved ships were saved from falling into British hands, but Rudolph Stark was again denied his last brave gesture of defiance. He retired to his Bavarian Alps, where he now lives, still painting pictures.

Lighthouse Keepers of the Sky

(Continued from page 9)

conditions getting steadily worse. Edward F. Plagge, operator in charge of the St. Louis radio station, was spending a few well-earned hours of leisure off duty. He was making himself comfortable in his home when suddenly his ears, keenly alert to aircraft engines, detected the drone of an approaching plane.

He ran to the window and looked out to see two Army ships flying at a very low altitude along the highway which passed his house. Conditions were anything but favorable for flying, and Plagge sensed that all was not well. They bored into the storm and were soon swallowed up. Shortly afterwards, he saw the two planes approaching again, flying in the opposite direction. They were evidently lost.

Plagge telephoned at once to the Airways communication station and instructed the operator to contact the planes by radio, or, if this was impossible, to broadcast their position and give directions for reaching the airport.

Radio Operator J. J. Tierny immediately sprang into action. "Two Army planes in the vicinity of St. Louis!" he began calling. There was no response, but he did not give up hope. He knew that the ships were cruising about aimlessly, looking for a place to sit down. "You are now south of the airport and headed north," he broadcast, hoping that the flyers would hear him. Then he gave instructions to assist them in using the radio range.

Fifteen minutes later, the airplanes were seen to circle and head in a north-

westerly direction. Evidently, they had not heard the broadcast. One of them disappeared from view, and the other returned, to fly along the highway where Plagge had first seen them.

Inside the cockpit of the plane, the bronzed, young officer was hunched forward to protect his face from the stinging snow. His eyes swept the bewildering mass of streets and buildings below him. There was no place down there where you could land even a kiddie-car. Instinctively, his eyes were drawn to the gas gauge, and the wavering needle told him that he couldn't stay up much longer. Once more he looked over the side of his cockpit. He couldn't bail out here and leave a pilotless plane, perhaps to plow into a crowd of people. No, he would have to stick to the end.

But he did not know that down below him he was being watched by alert eyes—eyes of experts who had been placed there by Uncle Sam to help out flyers in distress.

Suddenly he heard a voice as clear as a bell coming through his radio headphones. "Army plane in the vicinity of St. Louis," it called. Could this message be meant for him? He listened closely. Then, above the roar of his engine, he heard the crisp voice of the operator telling him where he was and how to get to the airport.

This was positively eerie. The operator was as calm and matter-of-fact about it as if he had been telling a motorist, face to face, which road to take. Immediately, the pilot changed his course and headed off in the direction indicated by that mysterious voice.

It was not long before he saw through the enshrouding murk the broad expanse of a flying field. What a welcome sight that was! He dragged it once and then sideslipped in for a landing.

The youngster was profuse in his thanks to the operators who had saved him from peril. He had missed the first broadcast, but the persistency of the airways men had borne fruit and he had picked up the second message, which had enabled him to reach safety. The other plane had flown west to get away from the storm and miraculously had landed without harm in a postage-stamp field some distance away.

ANOTHER unusual case was the flashing of a code message by an automobile light to assist in the rescue of three Navy seaplanes off the coast of California. It demonstrates that airways keepers are ready for any kind of emergency.

The planes, all of them two-seater observation types, were performing a mission out over the Pacific Ocean when they were entrapped in a soupy fog that made visibility practically nil and forced them to land. A heavy sea was running and, as the chances of rescue seemed slim, the flyers decided to try to reach shore by taxying through the water. Their gas tanks ran dry, however, and left them helplessly drifting with the tide.

Ensign Soucek, a member of the crew of one of the ships and kid brother

of Lieutenant Apollo Soucek, holder of the world's altitude record for air-planes, had an idea as to the general direction of the shore line, although it was invisible due to the fog. Anchoring his plane, Soucek dived into the water and struck out for shore. It was a long swim, but he finally arrived at the Oceanside airways station at about 9 p. m.

The keeper of the station immediately sent a call for help to San Diego, and two destroyers were dispatched to the scene. About 11.30 p. m., the keeper sighted the two greyhounds of the fleet, nosing their way along close to the shore, searching for the disabled planes. The destroyers were unable to locate the planes, due to the poor visibility.

As the airways keeper watched the futile search from the shore, a plan suddenly took form in his mind. He obtained a police car and, after having it driven to high ground, trained the spotlight on the destroyers and in Morse code flashed instructions to proceed on their course about three-fourths of a mile to the north, where they would find the planes. The destroyers immediately steamed off according to directions, and shortly afterwards rescued the planes and their crews.

This incident was a striking example of the resourcefulness of the guardians of our airways. Another case of considerable ingenuity occurred out at Des Moines not so long ago, when the automatic key which was tapping out the beam identification signals broke at a crucial time and the signals became garbled and meaningless. The junior operator investigated and found that the bracket holding the contact arm and spring had broken. This type of accident was so unusual that no spare part was available, and it looked like a lengthy delay. Meanwhile, pounding over the airways were transports heavily loaded with passengers whose lives were endangered.

The operator did some quick thinking, and then his eyes rested on a rubber band. That would not have meant much to most of us, but it gave him an idea. He used that rubber band to replace the bracket, then listened anxiously. It worked. Once more the signals rang out loud and true, and continued until spares could be obtained from the factory.

Another resourceful operator found it impossible to contact a transport when it was vital that he warn the pilot of the danger of going beyond his station. So the operator built huge fires and, when these attracted the attention of the airman, he signalled him to come in and land.

This kind of service is simply all a part of the job to the airways men. Operator Fitzpatrick, on duty at Wolcott, Indiana, summed up their attitude when he was congratulated for his initiative and cooperation. "We maintain," he stated, "that any services we are humanly able to render a pilot or passengers in case of emergency are not beyond our specified duty."



Actual "Goshawk" shown. P-26-A, Curtiss P6-E Hawk, Curtiss "Goshawk," Boeing F4B-4, and Curtiss "Swift." These are accurate and authentic. Smooth and glossy finish. Machine guns. Wingspan, about 6 inches. \$1.75 postpaid. No C.O.D. Canadian and foreign, 30% extra. Satisfaction guaranteed. MUELLER BROS., 28 Peach Street Buffalo, N. Y.

FINISHED SCALE MODELS
We build 3/16" scale reproductions of the following airplanes: S.P.A.D. 13, Fokker D-7, Albatross III, Newport 17-C, Fokker Triplane, Boeing P-26-A, Curtiss P6-E Hawk, Curtiss "Goshawk," Boeing F4B-4, and Curtiss "Swift." These are accurate and authentic. Smooth and glossy finish. Machine guns. Wingspan, about 6 inches. \$1.75 postpaid. No C.O.D. Canadian and foreign, 30% extra. Satisfaction guaranteed. MUELLER BROS., 28 Peach Street Buffalo, N. Y.



LOWEST PRICED Gasoline Motors for
Operating Boat and Airplane Models. 1- and 2-cylinder motors, 1" bore, 7/8" stroke, R.P.M. up to 6000. Send 10¢ in coin for information and sectional view drawing of 1-cylinder motor.

POWER MODEL BOAT & AIRPLANE CO.
134 So. Clinton Street Chicago, Ill. Dept. A-3

AVIATION ENGINEERS

ARE LEADERS IN MODERN PROGRESS



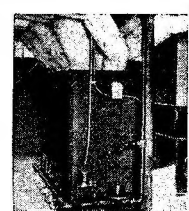
Expert knowledge of aviation engines is a long step toward success in this rapidly growing industry. Many aviation engineers today took their first step by mailing a coupon to I. C. S. at Scranton. Why don't you?

... INVENTION—a field of opportunity for men with ideas

If you have an inventive turn of mind, this new course in inventing and patenting will teach you all the basic knowledge you need to earn real money from your talents. The coupon will bring full information—FREE!



AIR CONDITIONING THE NEXT BIG INDUSTRY



Its opportunities are as big in winter as in summer. Plumbing and heating engineers must know Air Conditioning—the field in its broader aspects invites ambitious men. Write for information on the new Air Conditioning Course offered by the International Correspondence Schools.

RADIO holds great rewards for trained men

Almost in a decade radio has become a giant industry. The opportunities created will be enjoyed by trained men. The I. C. S. Radio Course, prepared by leading authorities, will help make you a trained man! A fascinating book—FREE.



INTERNATIONAL CORRESPONDENCE SCHOOLS

BOX 4159, SCRANTON, PENNA.

Without obligation, send me full information on subject checked below:

Aviation Engines
 Inventing and Patenting
 Air Conditioning
 Radio

<input type="checkbox"/> Architecture	<input type="checkbox"/> Highway Engineering
<input type="checkbox"/> Concrete Construction	<input type="checkbox"/> Poultry Farming
<input type="checkbox"/> Mechanical Engineering	<input type="checkbox"/> Drafting
<input type="checkbox"/> Reading Shop Blueprints	<input type="checkbox"/> Accounting
<input type="checkbox"/> Civil Engineering	<input type="checkbox"/> Good English
<input type="checkbox"/> Electrical Engineering	<input type="checkbox"/> Salesmanship
<input type="checkbox"/> Diesel Engines	<input type="checkbox"/> Advertising
<input type="checkbox"/> Gas Engine Operating	<input type="checkbox"/> Show Card Lettering
<input type="checkbox"/> Refrigeration	<input type="checkbox"/> Civil Service
<input type="checkbox"/> Chemistry	<input type="checkbox"/> High School Subjects

Name _____

Address _____

BUYERS' DIRECTORY

Airplanes and Accessories
Schools—Flying Instruction
\$5 per inch—Payable in Advance

AIRPLANES FOR SALE

New Aeroplanes, Less Motor, \$98.00

Powered with Ford motor and flight tested, \$148.00 each. New production, beautiful mid-wing design, complete with 7.00-4 air wheels. We expect to build several hundred. Send 25c for more information.

UNIVERSAL AIRCRAFT CO.
FORT WORTH, TEXAS

AIRPLANE SUPPLIES



Join Karl Ort's Young Men's Aviation League by sending me "Two Bits" (25c) today for my new 174 Aviation supply catalogue and I'll give you one of those beautiful Pilot's tool pins absolutely free of charge while they last. You win twice because the catalogue will save you many, many dollars on your purchases.

KARL ORT, 599 W. Poplar St., York, Pa.

INSTRUCTION

LEARN AVIATION

At the school where you Design, Build and Fly Airplanes. Big opportunities await you.

Write today for Catalog

U. S. Aircraft Engineering School, Inc.
1730 Grand Ave. Dept. O Kansas City, Mo.

AVIATION!!

APPRENTICESHIPS

AIR-MINDED Young Men interested in entering the field of Aviation as Apprentices. Write, enclosing stamp, to—


Mechanix-Universal Aviation Service
13291 Ardmore Dept. J Detroit, Mich.

\$19.95 Now buys a genuine **MEAD** Bicycle. RANGERS cost a few dollars more. Do not buy until you get our astonishing new prices and terms.

30 Days' Trial We ship on approval. If not satisfied after trial return the bicycle, lamps, wheels, equipment at half usual prices. Write for marvelous new prices and terms.

Mead CYCLE COMPANY
DEPT. B-75 CHICAGO

Write us today for free catalog



The U.S. AIR CORPS

Takes in this year 600 unmarried men between ages of 20 and 28 years and gives them **FREE FLYING TRAINING** consisting of 200 SOLO HOURS, including cross-country, and night flying. Gives them Special Uniforms, Transportation to the Field, Living Expenses, and also pays each man \$75 a month for learning to FLY. **PLenty OF FLYING HERE.** The Training Costs Absolutely Nothing. Let us Tell You: How to Get In. Information about Uniforms, Rank, Leave, and Actual Life at the New \$10,000,000 Field. Send your Name, Hand postman \$1 and postage when 9000-word information comes. It is **COMPLETE.** Nothing else to buy.

FLYING INTELLIGENCE BUREAU
401 Jud. K. Rives Bldg., Los Angeles, California

CLASSIFIED DIRECTORY

Use this Directory for prompt response. Rate: 10c per word (minimum 20 words). CASH WITH ORDER. February ads. must be in by December 1. Make remittances payable to: HARRY SAUNDERS, Classified Ad. Manager, 1450 Broadway, New York.

MODELS—MATERIALS—EQUIPMENT

JAPANESE Model Airplane Tissue, 32 colors, also Wood Veneer. Ask your dealer for Whitfield's paper—it's the best. Send for samples. Whitfield Paper Works, Inc., 18 Vestry Street, New York City.

FULL size plan 39" Sail Boat, \$1.50. Illustrated circular for 3c stamp. Tex Foster, 11313 Atlantic Ave., Richmond Hill, N. Y.

SAW BLADES (Band and Circular) for cutting Balsa. Special blades to order. Repair Service. M. Kaplan's Sons, 193B Centre St., New York.

Build the Berliner-Joyce OJ-2

(Continued from page 32)

rib "B", to the same size as the bottom, because on close observation you will notice that they are slightly different.

With all the ribs cut, tack them in place. Place the bottom spar, 1/8" x 1/16" in place. Next, place the top spar in place and glue the false spars to the top spar. The leading edge is 1/4" x 5/16". It is glued in place and then sanded to shape.

The wing tips are split bamboo bent to the shape shown on the plan. The top spar is broken and bent to meet the bamboo tip. Construct the center section in the same manner and glue it to the top right and left wing. Do not cover the wings yet.

The tail is constructed in the manner shown on Sheet 4. 1/16" dowels are used as the spars. Aluminum sleeves are inserted over the dowels so that the elevator can move freely. The ribs are shaped as shown on plan. After the stabilizer has been completed, construct the rudder in like manner. You will notice that the trailing edge of the rudder and stabilizer are set into the rib, while the leading edge lies flush with the rib (refer to Sheet 4).

MOTOR AND PROPELLER

THE model was designed to have a three-inch standard celluloid motor. In order that the motor should fit onto the front former, it will be necessary to alter the rear of the motor. Cut the back portion away so that the motor will lie flat against the first former. A metal motor plate is placed over the front of the motor, and an eyelet is passed through the center. Around the motor place an aluminum anti-drag cowl. The cowl should comply with the plan, as shown.

Little has to be said concerning the propeller other than the fact that you should exercise great care in carving the propeller. If you wish, you may obtain a shaped hub and attach the proper blades. Power the plane with three loops of 3/16" flat rubber. The shaft of the propeller is made from the same type of wire as is that of the rear hook. To assure a smooth rotating propeller, place a few washers on the shaft.

STRUTS

THE struts consist of the "N" strut, cabin struts, stabilizer struts, and landing gear struts. The struts are all streamlined and sanded to a smooth finish. The cabin struts (struts going from the center section of the top wing to the fuselage) are made so that they rest on a solid part of the stringers. If necessary, insert a small piece of balsa. The "N" struts are attached in like manner. The stabilizer struts are strips of bamboo cut to proper shape.

The landing gear is constructed as shown on the half-size three-view layout. The cross braces are inter-crossed, one brace entering through the other.

To obtain the brace with the loop, it will be necessary to cut the entire brace from a piece of wood the width of the loop. The other struts are all made as shown on the plan. The wheels are celluloid and attached to the hub.

Cover all the parts as you see fit. The color scheme is that used by the U. S. Navy. The markings of the ship are the stars of the wing and the U. S. NAVY on the side of the fuselage. All bracing wires are thread.

TO BUILD SOLID MODEL

USE the three-view layout shown on Sheet one to construct your model. Trace the top and bottom wings on a sheet of balsa corresponding to the thickness of the wing. This can easily be done with carbon paper. Cut out the wings. It will not be necessary to construct the top wing in three parts, because the right and left wings can easily be tilted up at a two-degree angle.

The tail is traced and cut out in the same manner as are the wings. After both the tail and the wings are cut, sand them to the cross-sectional shape shown on the plan. For accurate shape of the cross-section, see wing section C-72.

Trace the side view on a block of balsa that has the same dimensions as shown on plan. Cut the shape out and sand to the line. Then streamline the top as shown on plan. After you have completed the body thus far, round off the edges and sand the complete body to the cross-sectional shape given on the plan. Cut out the position of the cockpits.

The motor can easily be built by cutting the cylinders off a small motor and gluing them around a balsa motor case. If you wish, you can also build the motor and the cowl from one piece, painting the motor part black.

Now assemble the complete ship. It will be advisable to give the parts a few coats of banana oil and then sand the parts until a smooth surface is obtained.

The first part to be attached to the fuselage is the stabilizer, next the rudder. With the complete tail in place, use it as a guide and construct the landing gear. Glue the bottom wings in place, making sure that a two-degree dihedral angle is made with the lateral axis. Attach the struts going into the center section as explained on the plan.

Using them as a base, lay the top wing in place and set away to dry. The top wing also has a two-degree dihedral angle. After the wing has completely dried, attach the "N" struts. The plane is now complete with the exception of the rigging, which is done with black thread.

Paint the plane any color you wish. A good suggestion would be either silver or white (Navy colors). The stars and other insignia are all shown on the plan. I suggest that you give the ship two coats of paint. Mix the paint with acetone.

READ ABOUT THESE DANDY SOLID WOOD KITS

Fine For Christmas Presents

You can not go wrong with
HAWK'S KITS

All with
1935 Improvements

4 for \$1.50 plus 10%
for postage

Exact 1/4-inch Scale Models—Solid Wood

You will like these kits. Try them.
You will want more. Be the first in
your neighborhood to have them.

Here is what you get

Each Hawk Kit contains all wood parts, as
fuselage, wings, stabilizer, and rudder, CUT
TO OUTLINE SHAPE. Die cast machine
guns, propellers and wheels are furnished
in each kit. Kits requiring radial motors
have die cast motors included. All sets
have formed metal seats, good paint, glue,
insignia and real scale plans. PROOF of
this can be seen in these pictures.



Monocoupe

We Offer You the Following Kits

Any **4 for \$1.50** plus 10%
for postage

Exact 1/4-inch Scale Models—Solid Wood

Pick them out now—immediate de-
livery guaranteed. Send Now.

- Ansaldo S.V.A.
- Westland Wagtail
- Fokker Triplane
- Boeing P26
- Boeing F4B-3
- Bristol Fighter
- B/J Seaplane
- Curtiss Racer
- Nieuport 17
- Hawker Fury
- Sopwith Pup
- Curtiss Swift
- Nieuport 28
- Supermarine
- Halberstadt

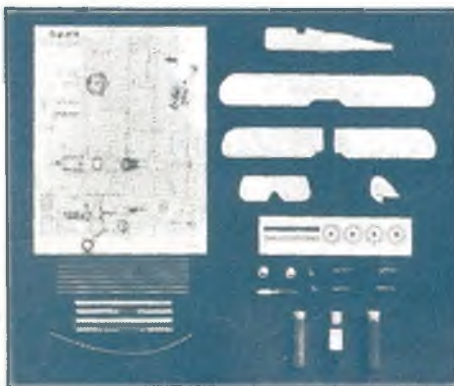
- Hawk P-6-E
- Navy Racer
- S.E.5A
- Fokker D7
- Fokker D8
- Pfalz D12
- Hawk P-5
- Albatross
- Pfalz D3
- Autogiro
- Spad 13

- B/J 16
- Camel
- DeHaviland 4
- DeHaviland 5
- Monocoupe
- Vought V65

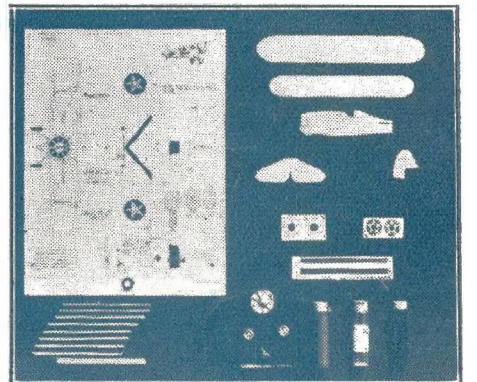
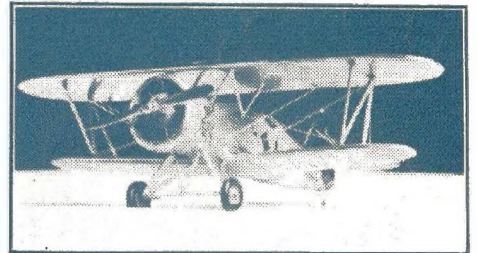
SINGLE KIT

50c

plus 10% for postage



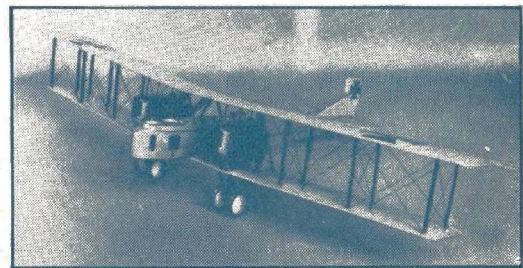
DeHaviland 4



Boeing F4B-3



THE HANDLEY-PAGE 0-400



THE GOTHA BOMB DROPPER

Don't fail to build these famous World War Bombing Planes

The Handley-Page and Gotha Bomber kits contain all wood parts (CUT TO OUTLINE SHAPE), die cast propellers, machine guns and wheels, metal bucket seats, all insignia and numerals, over-size portions of high-class airplane paint and cement, exact scale drawing, etc., comprise the kit sets.

HANDLEY-PAGE KIT, wingspan 25 inches,
in Pine or Balsa **\$3.00** plus 10% for postage

GOTHA BOMBER KIT, wingspan 19 1/4 inches,
in Pine or Balsa **\$1.65** plus 10% for postage

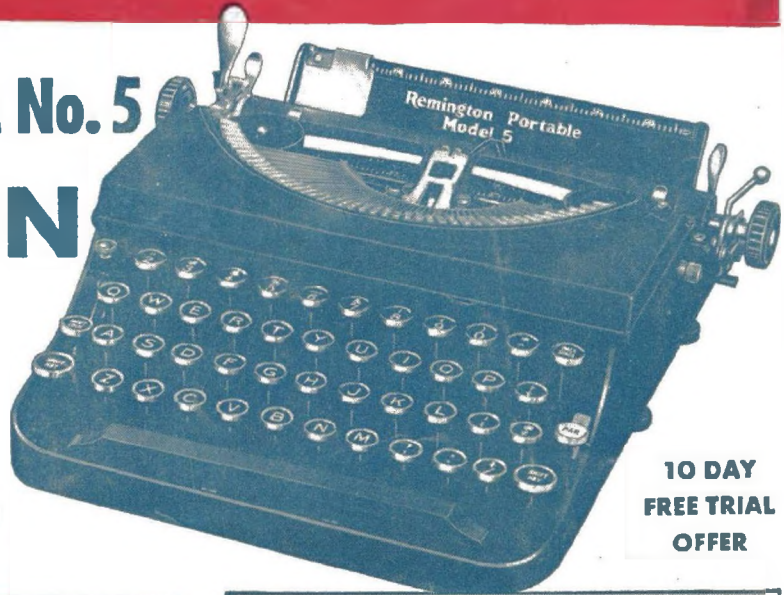
Boeing Bomber Y1B-9A - \$1.65
Boeing Transport 247 - \$1.65 } Plus
postage

HAWK MODEL AIRPLANES

4946 Irving Park Blvd., Dept. F6, Chicago, Ill.

ANNOUNCING AMAZING TYPEWRITER BARGAIN

BRAND NEW MODEL No. 5
**REMINGTON
PORTABLE**
10¢ A DAY
MONEY BACK GUARANTEE



**10 DAY
FREE TRIAL
OFFER**

BIG PRICE REDUCTION

● Positively the greatest portable typewriter bargain ever offered! Now for the first time Remington, world-famous manufacturer, offers a NEW purchase plan... only 10¢ a day buys this latest model machine! Not a used or rebuilt typewriter. Not an incomplete machine. A beautiful brand new regulation Remington Portable. Standard 4-row keyboard; Standard width carriage; margin release on keyboard; back spacer; automatic ribbon reverse; every essential feature found in standard typewriters!

Money making opportunities always open

Hundreds of jobs are waiting for people who can type. A typewriter helps put your ideas on paper in logical, impressive form... helps you write clear, understandable sales reports, letters, articles, or stories. A Remington Portable has started many a young man and woman on the road to success.



A Gift for Every Member of the Family

If you want a gift for birthday, Christmas, or graduation... one that Father, Mother, Sister or Brother will use and appreciate for years to come... give a Remington Portable. It's the one gift that can be used with both pleasure and profit by every member of the family.

ACT...WHILE LOW PRICE HOLDS GOOD!

New wage scales in our own factories, and in the factories of the companies which make our materials, point definitely to higher prices. Stocks of machines on hand make possible the present unbelievably low cash price on this machine. Everything points to higher prices. We don't believe that we can maintain the present big price reduction in the face of constantly rising costs in every one of our departments. So we say... "Act fast!"

10 DAY FREE TRIAL OFFER

You can try this machine for 10 days without risking one penny of your money. Not even shipping charges. Send for complete details on this most liberal offer. Get attractive new catalogue illustrating and describing the many Remington models available on unusually low terms. Clip coupon today!

EVERY ESSENTIAL FEATURE found in Standard Machines

Buying a typewriter isn't like buying a suit of clothes. Many Remington portables, seeing 10 years of hard service are still in active use. When you buy... buy a machine with every standard feature. The Remington No. 5 is the most compact and durable portable ever built... includes all essential standard typewriter features. This beautiful machine

represents the height of economy... unequalled economy in first cost... unequalled economy in service.

It is today the best value ever offered in typewriter history... and that statement comes from the company that has constantly made typewriter history. Buy now. It is a real bargain offer.

Specifications...

The Model 5 includes every essential feature found in standard typewriters. It has standard 4-row keyboard. Complete visibility. Standard width carriage for long envelopes. Carriage return lever of exceptional design for easy and rapid operation.

Margin release on the keyboard. Automatic ribbon reverse. Back spacer. Two color ribbon shift. Variable line spacer. Adjustable margin stops. Auto set Paragraph Key (one of the most useful features found on any typewriter). Weight 11 lbs. 13 oz. Furnished with Pica or Elite type.

TYPING COURSE FREE

When you get your new Remington No. 5, you will get with it... ABSOLUTELY FREE... a 19-page course in typing. It teaches the Touch System, speeds up work. It is simply written and well illustrated. Instructions are easy as A, B, C. Even a child can understand this method. A little study and the average person, child or grown-up, becomes fascinated. Follow this course during the 10-DAY FREE TRIAL OFFER that we give you on your typewriter. At the end of that time, you should be able to dash off letters faster than with pen and ink.



CARRYING CASE FREE

With every Remington No. 5, a FREE carrying case sturdily built of 3-ply wood. Covered with heavy DuPont fabric. Top is removed in one motion, leaving machine firmly attached to base. Can be used anywhere... on knees, in chairs, on trains.



Remington Rand Inc., Dept. 128-1, Buffalo, N. Y.
Please tell me how I can buy a new Remington Portable typewriter for only 10¢ a day. Also enclose your new catalog.

Name _____
Address _____
City _____ State _____

CLIP COUPON NOW

REMINGTON RAND INC., DEPT. 128-1, BUFFALO, N. Y.